



R-SERIES BAR CONTACTORS UP TO 5000A



CHS Controls AB
Tel +46 42 38 61 00, Fax +46 42 38 61 29
chs@chscontrols.se www.chscontrols.se

TELARC

Motor rated operational powers and currents

The currents given below concern standard three-phase four-pole cage motors (1500 r.p.m. at 50 Hz 1800 r.p.m. at 60 Hz). These values are given for guidance and may vary according to the motor manufacturer and depending on the number of poles.

IEC Motor power kW	Motor nominal current: standardized values in blue colour (according to IEC 60947-4-1 Annex G)									
	220 V A	230 V A	240 V A	380 V A	400 V A	415 V A	440 V A	500 V A	660 V A	690 V A
0.06	0.37	0.35	0.34	0.21	0.2	0.19	0.18	0.16	0.13	0.12
0.09	0.54	0.52	0.50	0.32	0.3	0.29	0.26	0.24	0.18	0.17
0.12	0.73	0.7	0.67	0.46	0.44	0.42	0.39	0.32	0.24	0.23
0.18	1	1	1	0.63	0.6	0.58	0.53	0.48	0.37	0.35
0.25	1.6	1.5	1.4	0.9	0.85	0.82	0.74	0.68	0.51	0.49
0.37	2.0	1.9	1.8	1.2	1.1	1.1	1	0.88	0.67	0.64
0.55	2.7	2.6	2.5	1.6	1.5	1.4	1.3	1.2	0.91	0.87
0.75	3.5	3.3	3.2	2.0	1.9	1.8	1.7	1.5	1.15	1.1
1.1	4.9	4.7	4.5	2.8	2.7	2.6	2.4	2.2	1.7	1.6
1.5	6.6	6.3	6	3.8	3.6	3.5	3.2	2.9	2.2	2.1
2.2	8.9	8.5	8.1	5.2	4.9	4.7	4.3	3.9	2.9	2.8
3	11.8	11.3	10.8	6.8	6.5	6.3	5.7	5.2	4	3.8
4	15.7	15	14.4	8.9	8.5	8.2	7.4	6.8	5.1	4.9
5.5	20.9	20	19.2	12.1	11.5	11.1	10.1	9.2	7	6.7
7.5	28.2	27	25.9	16.3	15.5	14.9	13.6	12.4	9.3	8.9
11	39.7	38	36.4	23.2	22	21.2	19.3	17.6	13.4	12.8
15	53.3	51	48.9	30.5	29	28	25.4	23	17.8	17
18.5	63.8	61	58.5	36.8	35	33.7	30.7	28	22	21
22	75.3	72	69	43.2	41	39.5	35.9	33	25.1	24
30	100	96	92	57.9	55	53	48.2	44	33.5	32
37	120	115	110	69	66	64	58	53	40.8	39
45	146	140	134	84	80	77	70	64	49.1	47
55	177	169	162	102	97	93	85	78	59.6	57
75	240	230	220	139	132	127	116	106	81	77
90	291	278	266	168	160	154	140	128	97	93
110	355	340	326	205	195	188	171	156	118	113
132	418	400	383	242	230	222	202	184	140	134
160	509	487	467	295	280	270	245	224	169	162
200	637	609	584	368	350	337	307	280	212	203
250	782	748	717	453	430	414	377	344	261	250
315	983	940	901	568	540	520	473	432	327	313
355	1109	1061	1017	642	610	588	535	488	370	354
400	1255	1200	1150	726	690	665	605	552	418	400
500	1545	1478	1416	895	850	819	745	680	515	493
560	1727	1652	1583	1000	950	916	832	760	576	551
630	1928	1844	1767	1116	1060	1022	929	848	643	615
710	2164	2070	1984	1253	1190	1147	1043	952	721	690
800	2446	2340	2243	1417	1346	1297	1179	1076	815	780
900	2760	2640	2530	1598	1518	1463	1330	1214	920	880
1000	3042	2910	2789	1761	1673	1613	1466	1339	1014	970

UL / CSA Motor power hp	Motor nominal current: standardized values (according to IEC 60947-4-1 Annex G and UL 508)				
	208 V A	220-240 V A	380-415 V A	440-480 V A	550-600 V A
1/2	2.4	2.2	1.3	1.1	0.9
3/4	3.5	3.2	1.8	1.6	1.3
1	4.6	4.2	2.3	2.1	1.7
1-1/2	6.6	6	3.3	3	2.4
2	7.5	6.8	4.3	3.4	2.7
3	10.6	9.6	6.1	4.8	3.9
5	16.7	15.2	9.7	7.6	6.1
7-1/2	24.2	22	14	11	9
10	30.8	28	18	14	11
15	46.2	42	27	21	17
20	59.4	54	34	27	22
25	74.8	68	44	34	27
30	88	80	51	40	32
40	114	104	66	52	41
50	143	130	83	65	52
60	169	154	103	77	62
75	211	192	128	96	77
100	273	248	165	124	99
125	343	312	208	156	125
150	396	360	240	180	144
200	528	480	320	240	192
250	-	604	403	302	242
300	-	722	482	361	289
350	-	828	560	414	336
400	-	954	636	477	382
450	-	1030	-	515	412
500	-	1180	786	590	472



R contactors

Control of AC and DC power circuits up to 5000 A

Overview	1
Construction characteristics	2
AC circuit switching	3
DC circuit switching	4
Advanced applications	5
General technical data	6
Accessories and spare parts	7
Terminal marking and wiring diagrams	8
Dimensions	9
Terms and definitions	10
Questionnaire	11
Index	12
Marketing material	13



R contactors

Tailored to your needs

1 With over 100 years of experience in control, Telarc has designed its R contactors to meet the particular requirements of power applications from 63 A up to 5000 A in AC and DC.

With a variable number of poles and advanced features, these tailor-made bar mounted contactors remain the most flexible solution. Robustness and reliability bring our technology far beyond the limits of standard contactors. Our know-how enables us to offer R contactors perfectly suited to your applications whatever the environment.

Performance

- High making and breaking capacity
- Current up to 5000 A
- Voltage up to 1000 V AC or 1500 V DC.

Flexibility

- Variable number of poles
- Combination of N.O. and N.C. poles
- Adjustable number of auxiliary contacts.

Reliability

- Robust construction
- Durability up to 5 millions of operating cycles
- Experienced and proven for years.

... you can trust

Easy maintenance

- Direct access to all the contactor parts for inspection or replacement
- Complete and didactic instruction manual for installation, inspection or maintenance
- Dedicated R contactors service support available.

From standard to tailor-made solution

- Pre-sales support to identify and define customer requirements
- Customized support with development of solutions from specifications
- Specialists available to optimize your configuration.

Sustainability of control for a wide variety of applications

- Iron and steel industries
- Mining
- Cranes
- Induction furnaces
- Hydroelectric power stations
- Photovoltaic power plants
- Power distribution
- Energy storage
- Railway substation
- Lighting equipment
- Pump stations.



R contactors

Get the right product

Conventional applications

AC circuit switching

Up to 500 V AC
IOR contactors

From 500 up to 1000 V AC
IOR..MT contactors



AC-1 Rated operational current up to 5000 A
AC-3 Rated power up to 1500 kW (1520 A - 440 V)

DC circuit switching

Up to 1500 V DC with poles in series
IOR..CC contactors



DC-1 Rated operational current up to 5000 A
DC-3 / DC-5 operational current up to 2000 A

Advanced applications

N.O./N.C. main poles combination

AC circuit switching
NOR..MT contactors

DC circuit switching
NOR..CC contactors



Power circuit coupling

Up to 1000 V AC / 1500 V DC
LOR couplers



Slip-ring motor control

Uer up to 5000 V AC
FOR contactors



Energy saving and safety requirements

Equipped with latching
..AMA, ..AME contactor types



Alternator field discharge

Umax 2250 V DC
AM-CC-JORE contactors



R contactors for AC circuit switching

1

Rated operational voltage

U_e from 500 up to **1000 V AC**



Contactor type	AC control circuit	~	IORR63..MT	IORR125..MT	IORR200..MT	IORR400..MT	IORR500..MT	IORR800..MT
	DC control circuit	≡	IORE63..MT	IORE125..MT	IORE200..MT	IORE400..MT	IORE500..MT	IORE800..MT
Categories	U _e							
AC-1	at 40 °C	le	85 A	170 A	260 A	400 A	550 A	800 A
AC-3	690 V AC	le	85 A	160 A	260 A	400 A	550 A	800 A
	1000 V AC max.	le	56 A	105 A	180 A	280 A	380 A	580 A
AC-3	690 V AC	Power	80 kW	150 kW	240 kW	400 kW	540 kW	780 kW

Rated operational voltage

U_e up to **500 V AC**

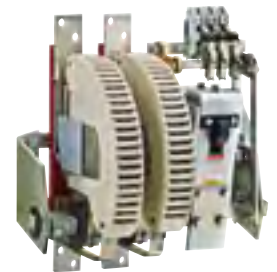

Contactor type	AC control circuit	~	-					IORR800
	DC control circuit	≡	-					IORE800
Categories	U _e							
AC-1	at 40 °C	le	From 85 A to 550 A, select above IOR...-MT					900 A
AC-3	380-415-440 V AC	le	-					800 A
	500 V AC max.	le	-					800 A
AC-3	400 V AC	Power	-					450 kW

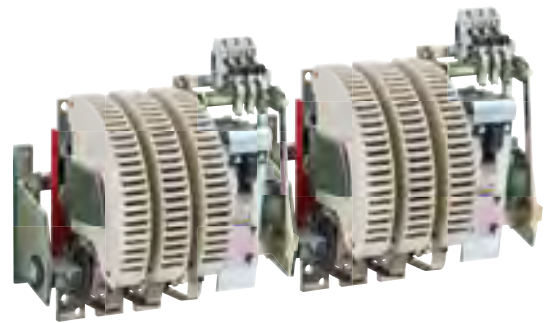
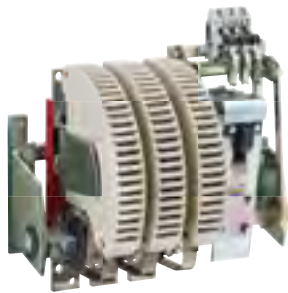

IORR1400..MT	IORR1700..MT	IORR2100..MT	IORR2500..MT	IORR3200..MT	IORR3800..MT	IORR4500..MT	IORR5100..MT
IORE1400..MT	IORE1700..MT	IORE2100..MT	IORE2500..MT	IORE3200..MT	IORE3800..MT	IORE4500..MT	IORE5100..MT

1250 A	1650 A	1850 A	2200 A	3000 A	3500 A	4000 A	4500 A
970 A	1170 A	1270 A	-	-	-	-	-
610 A	680 A	810 A	-	-	-	-	-
1000 kW	1200 kW	1300 kW	-	-	-	-	-

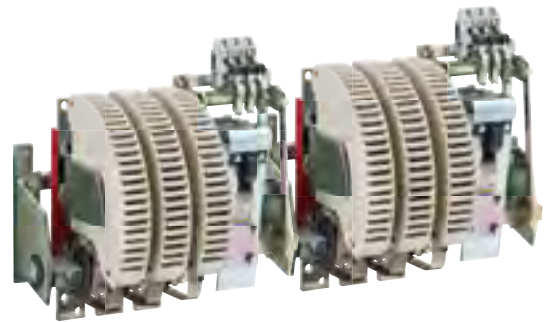
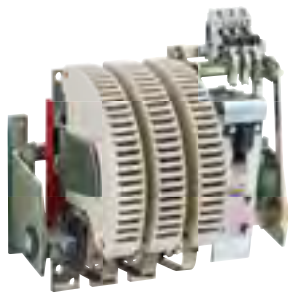

IORR1000	IORR1400	IORR1700	IORR2100	IORR2500	IORR3200	IORR3800	IORR4500	IORR5100
IORE1000	IORE1400	IORE1700	IORE2100	IORE2500	IORE3200	IORE3800	IORE4500	IORE5100

1000 A	1350 A	1650 A	2000 A	2400 A	3200 A	3800 A	4500 A	5000 A
800 A	1080 A	1260 A	1520 A	-	-	-	-	-
800 A	1080 A	1220 A	1340 A	-	-	-	-	-
450 kW	630 kW	750 kW	900 kW	-	-	-	-	-

R contactors for DC circuit switching

1

Rated operational voltage
 U_e up to **1500 V DC**

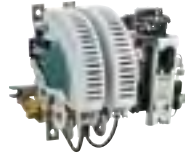

Contactor type	AC control circuit	~	IORR63..CC	IORR125..CC	IORR200..CC	IORR400..CC	IORR500..CC
	DC control circuit	≡	IORE63..CC	IORE125..CC	IORE200..CC	IORE400..CC	IORE500..CC
Number of poles in series	Categories	U _e max.					
1 pole	DC-1	500 V DC	I _e 85 A	170 A	275 A	400 A	550 A
	DC-3 / DC-5	500 V DC	I _e 68 A	125 A	205 A	350 A	500 A
2 poles	DC-1	1000 V DC	I _e 85 A	170 A	275 A	400 A*	550 A*
	DC-3 / DC-5	1000 V DC	I _e 68 A	125 A	205 A	350 A	500 A
3 poles	DC-1	1500 V DC	I _e 85 A*	170 A*	275 A*	400 A*	550 A*
	DC-3 / DC-5	1500 V DC	I _e 68 A*	125 A*	205 A*	350 A*	500 A*

* U_e max. = 1500 V DC, version with increased insulation for 1000 V DC < U_e ≤ 1500 V DC, please consult us.



Contactors
 UL / CSA approved 

Rated operational voltage
 U_e up to **600 V DC**

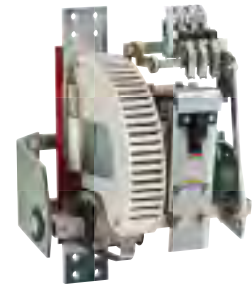
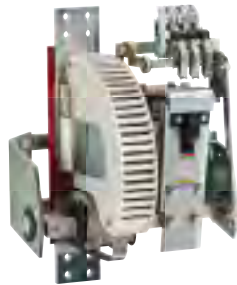

Contactor type	AC control circuit	~	IORR800-10-CC	IORR1000-10-CC	IORR1400-10-CC	IORR1700-10-CC	IORR2100-10-CC
	DC control circuit	≡	IORE800-10-CC	IORE1000-10-CC	IORE1400-10-CC	IORE1700-10-CC	IORE2100-10-CC
	U max.						
1 pole	General use	600 V DC	I _e 800 A	1000 A	1300 A	1700 A	2000 A

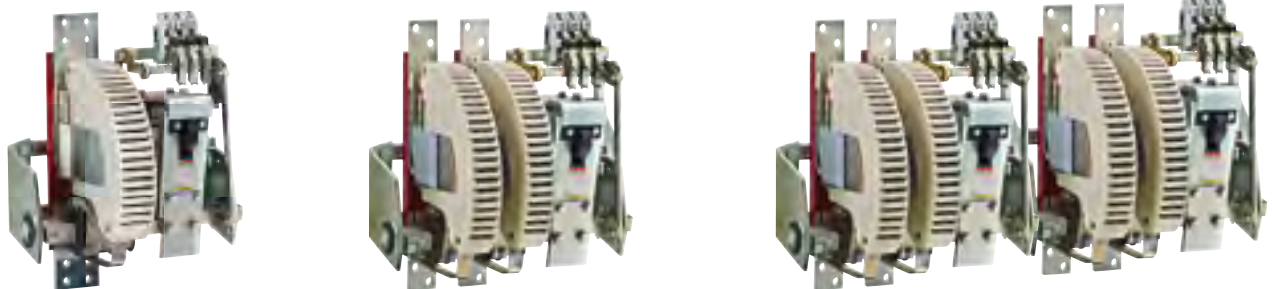

	IORR800..CC	IORR1000..CC	IORR1400..CC	IORR1700..CC	IORR2100..CC	IORR2500..CC	IORR3200..CC	IORR3800..CC	IORR4500..CC	IORR5100..CC
	IORE800..CC	IORE1000..CC	IORE1400..CC	IORE1700..CC	IORE2100..CC	IORE2500..CC	IORE3200..CC	IORE3800..CC	IORE4500..CC	IORE5100..CC

Ue max.

750 V DC	800 A	1000 A	1250 A	1600 A	2000 A	2300 A	3200 A	3800 A	4500 A	5000 A
600 V DC	720 A	1000 A	1250 A	1600 A	2000 A	On request	On request	On request	On request	On request
1500 V DC	800 A	1000 A	1250 A	1600 A	2000 A	2300 A	3200 A	3800 A	4500 A	5000 A
1000 V DC	720 A	1000 A	1250 A	1600 A	2000 A	On request	On request	On request	On request	On request
1500 V DC	800 A	1000 A	1250 A	1600 A	2000 A	2300 A	3200 A	3800 A	4500 A	5000 A
1500 V DC	720 A	1000 A	1250 A	1600 A	2000 A	On request	On request	On request	On request	On request



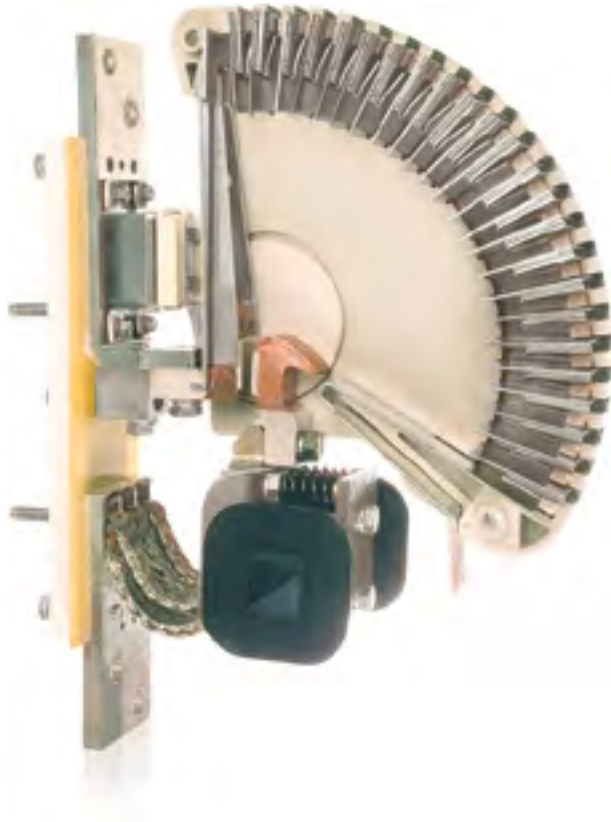

Construction characteristics

Construction characteristics	2/2
Contactors with magnetical latching ..AMA type	2/4
Contactors with mechanical latching ..AME type	2/5
Type and order code for R contactors	2/6
Coil voltage and blowout type	2/7
Auxiliary contacts	
Main characteristics	2/8
Selection tables	2/9



Construction characteristics

2

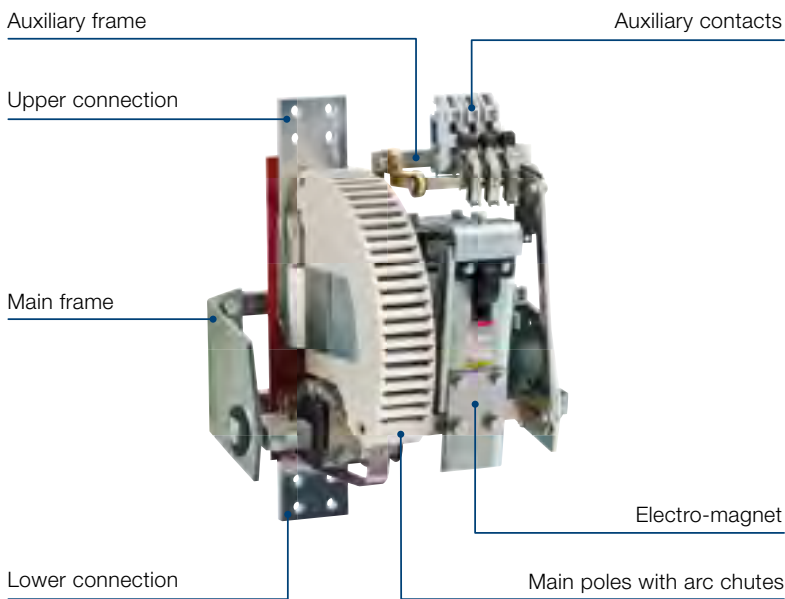

This design offers a great flexibility with standard types as well as special variants

Flexible design

R contactors are built with a main frame supporting main poles, electro-magnet, auxiliary contacts and propose:

- Variable number of N.O. and N.C. poles, with or without blowout coils
- Large number of N.O. and N.C. auxiliary contacts
- Control circuit for standard and specific voltages
- Mechanical or magnetical latching available.

All parts are easily accessible and removable from the front.

Main frame

The main frame is designed with a fixed bar and a rotating shaft linked by 2 bearings. All parts (poles, electro-magnet, auxiliary contacts) are mounted on this frame.

Small frame for R63 ... R500 contactors

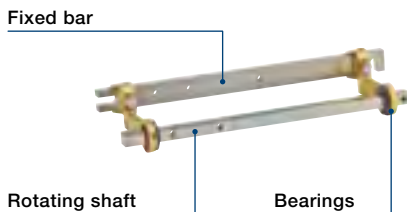

Large frame for R800 ... R5100 contactors

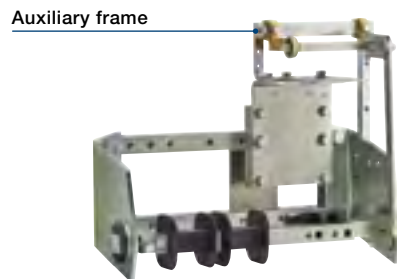

Main poles

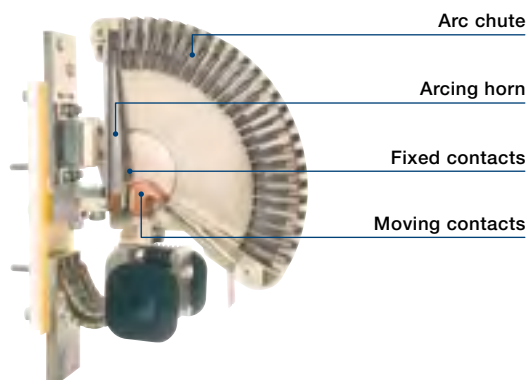

The moving contacts are similarly mounted and move directly with the rotating shaft.

A blowout coil

The standard blowout coil is rated to carry the total current flowing through the poles.

Arc chutes

It ensures a rapid extinction of the arcs. Quick and easy removal of the arc chutes allows an easy inspection of the contacts and their replacement if necessary.

Arcing horn

It assists the elongation and breaking of the electric arc (not applicable to LOR couplers).

Each pole is designed with:

Fixed and moving contacts

The fixed contacts are mounted on an insulated support screwed onto the fixed bar.

Construction characteristics

Low current breaking for DC circuits

R63 ... R2100 contactors

If the breaking current is lower than 50 % of the contactor rating, permanent magnet must be added. Please consult us. Refer to blowout code table in DC circuit switching

Control circuit

Rectifier

Economy resistor



The electro-magnet is built with a magnetic circuit and a coil. It is mounted on the right side or on the frame center, in standard. It can be mounted on the left side on request.

AC control circuit supply: RR electro-magnet

The coil is fed from an AC supply via a rectifier and an economy resistor.

The control supply frequency is 50/60 Hz in standard. For others frequencies, please consult us.

DC control circuit supply: RE electro-magnet

The coil is fed from a DC supply via an economy resistor.

Latching version (see following pages)

Magnetical latching for R63 ... R200

Mechanical latching for R500 ... R5100

Low consumption coil for R63 ... R500 contactors (on request)

- Up to 6 times less in control power consumption at holding
- Reduced width up to 15 % compared to standard R contactors
- Control voltage available:
 - 24...440 V 50 / 60 Hz
 - 24...250 V DC
- Example of type: IORE63..-LC.

Principle

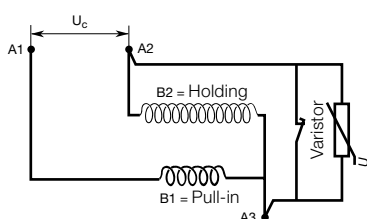

A varistor and a lagging contact for holding winding insertion are factory mounted.

Only a part of the winding (B1) is energized at closing. After opening the NC contact, the complete coil (B1 + B2) is used for contactor holding.

Contactors with magnetical latching ..AMA type

2



For R63 ... R200 contactors

Description

Contactors with magnetical latching are very similar to standard contactor in construction and dimensions. Only the electro-magnet and the coil have a specific design.

AC operated: ..RR..AMA

DC operated: ..R..AMA

A permanent magnet is mounted in the upper part of the fixed laminated circuit.

The double-winding coil is always fed from d.c. supply (from rectifier for IORR..AMA type) and has:

- 1 terminal for "De-latching" + marked "A1" (red)
- 1 terminal for "Latching" + marked "A2" (red)
- 1 common terminal (blue).

Coil windings are only energized at the point of opening and closing of the contactor.

1 N.O. auxiliary contact is fitted as standard. For additional auxiliary contact, refer to "Auxiliary contact fitting details".

Applications

- Contactors which remain permanently closed, that allows energy saving
- Installations where the control circuits are fed from batteries and where it's needed to reduce the power consumption
- In case of accidental supply failure, the user knows the state (ON or OFF) of the contactor when the failure occurred
- Contactors which must remain closed for safety reasons, even if the control circuit current decreases
- Contactors in distribution circuits. The contactor is used as an isolating switch
- Protection against accidental failure of the main supply.

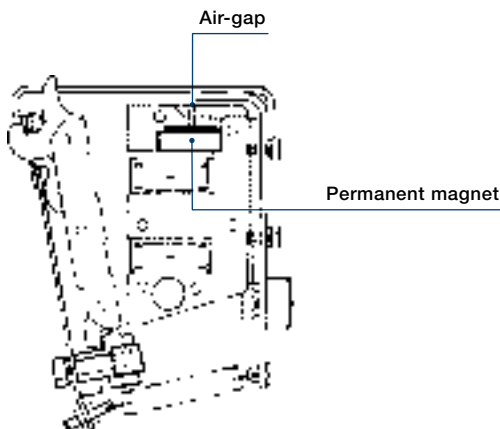

Electro-magnet of contactors ..AMA

Operation

Contactor closing (latching)

The electro-magnet being open, the coil winding (1) is fed via the contact B with a current i_1 . The strength and direction of the magnetic field produced in this winding is the same as that produced by the permanent magnet.

Contactor opening (de-latching)

The electro-magnet being closed, the coil winding (2) is fed via the contact A with a current i_2 . The direction of the field produced by current i_2 , open the contactor.

Contactor opening and closing

On opening and closing of the contactor, the coil is immediately de-energized by auxiliary contacts B and A mounted on the contactor.

Mechanical durability

0.2 millions of operating cycles.

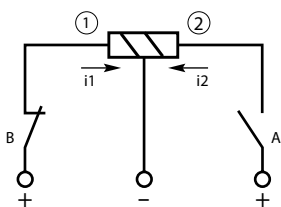

Block diagram

Contactors with mechanical latching ..AME type

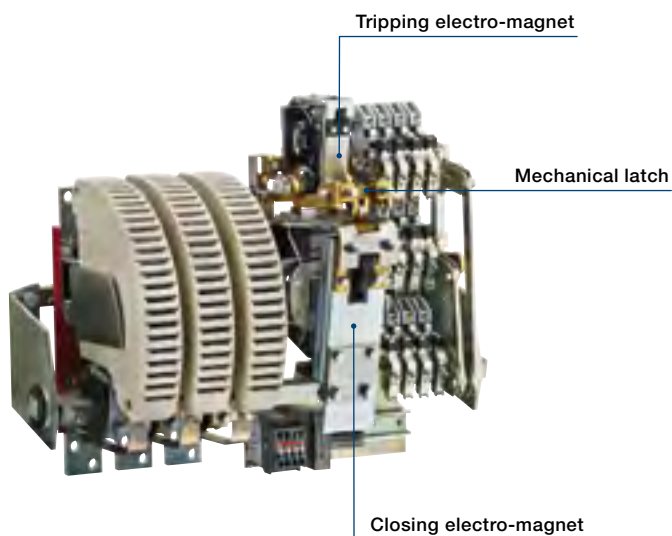

For R500 ... R5100 contactors

Description

Contactors with mechanical latching differ from standard contactor by a double electro-magnet (with closing and tripping electro-magnet, electrically separated).

A mechanical latch is mounted above the closing electro-magnet. The tripping electro-magnet releases the mechanical latch. No auxiliary contacts are fitted as standard for ..AME types. For additional auxiliary contacts, refer to "Auxiliary contact fitting details".

AC operated: ..RR..AME

DC operated: ..RE..AME

Applications

- Contactors which remain permanently closed, that allows energy saving
- Installations where the control circuits are fed from batteries and where it's needed to reduce the power consumption
- In case of accidental supply failure, the user knows the state (ON or OFF) of the contactor when the failure occurred
- Contactors which must remain closed for safety reasons, even if the control circuit current decreases
- Contactors in distribution circuits. The contactor is used as an isolating switch
- Protection against accidental failure of the main supply.

Operation

Contactor closing (latching)

Once the closing coil is energized, the contactor closes. It remains in this position by the mechanical latch action. The closing coil is de-energized by an electrical interlocking contact.

Contactor opening (de-latching)

Once the tripping coil is energized, the mechanical latch is released and the contactor opens. The tripping coil is de-energized by an electrical interlocking contact.

Mechanical durability

0.2 millions of operating cycles.

Variant

AMF types with 2 tripping coils are available on request.



Type and order code for R contactors

Example:

IORE800-30-MT-AME, 220 V DC coil + 1 CA15-F + 1 CA15-O

R contactor with RE electro-magnet and circuit for DC operation via an economy resistor, 800 A rating, 3 N.O. main poles, 0 N.C. main pole, with mechanical latching, 220 V DC coil + 1 extra CA15-F (N.O.) auxiliary contact block + 1 extra CA15-O (N.C.) auxiliary contact (total auxiliary contacts: 1 N.O. + 1 N.C.)

Type

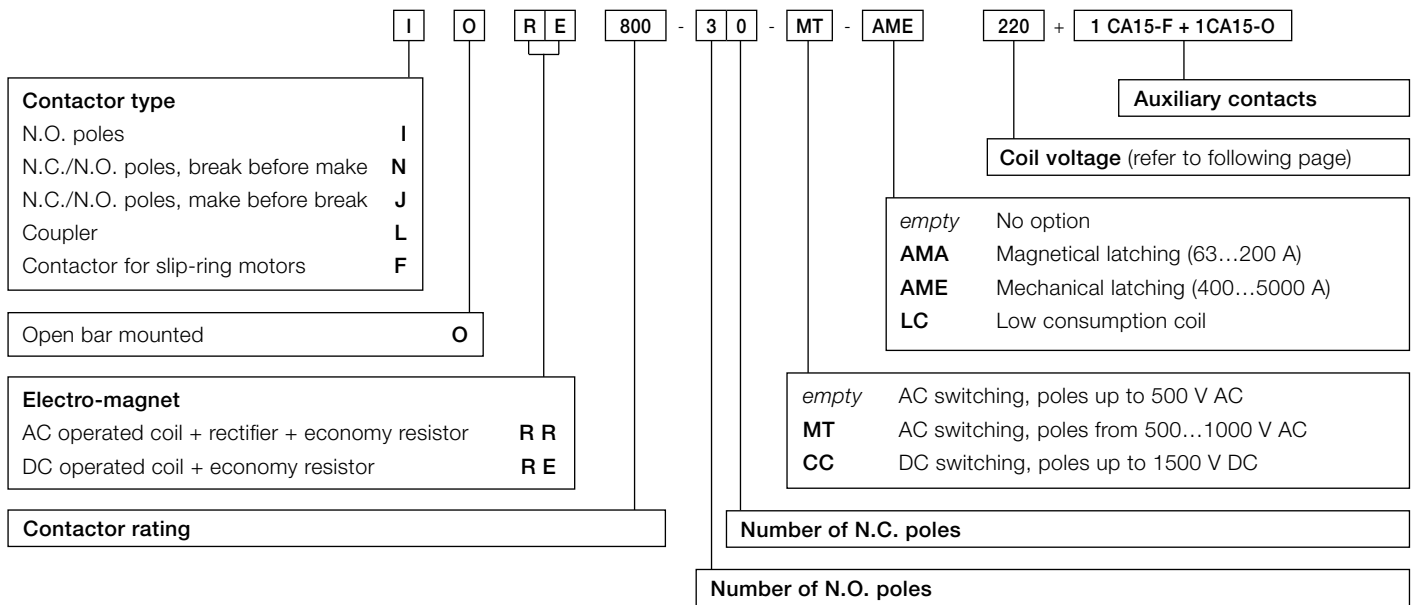

Order code

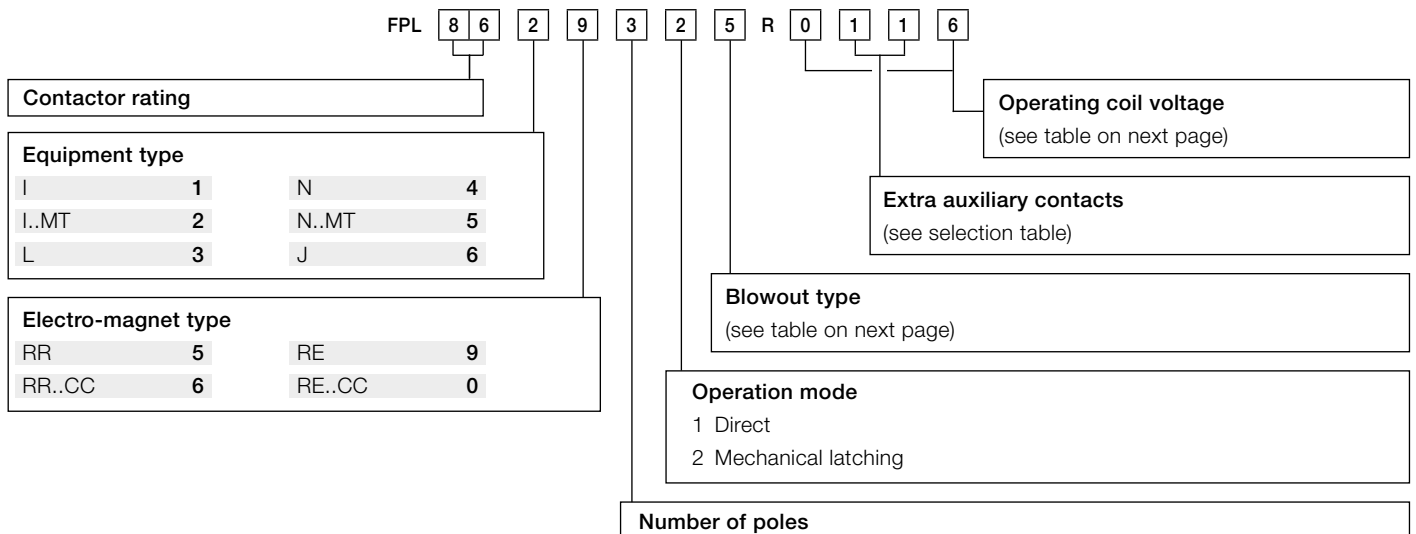

Notes:
 - Additional auxiliary contacts can be ordered separately and mounted by the user if the fixed dimension F doesn't increase (see Auxiliary contact fitting details table).
 - Order code or contactor rating must be specified when the CA15 auxiliary contact are ordered separately.

Coil voltage and blowout type Selection table

Complete the boxes by the codes indicated in the tables.

Coil voltage code table

Type	RE	Code
RR	R..AMA	
RR..AMA	R..AME	
RR..AME		
V 50-60 Hz	V DC	R <input type="checkbox"/> <input type="checkbox"/>
24 (1)	24 (1)	R0_1
-	30 (1)	R1_4
32 (1)	-	R1_5
-	36 (1)	R1_6
42 (1)	42 (1)	R0_2
48	48	R1_7
-	60	R0_3
60	-	R1_9
-	75	R2_0
100	-	R2_2
110-115	110	R0_4
120	120	R2_3
-	125-130	R0_5
127	-	R2_4
-	185	R2_7
200	-	R2_8
210	-	R4_5
220-230	220	R0_6
-	230	R4_6
230-240	240	R2_9
250	250	R4_0
380-400	380	R0_7
400	400	R3_9
400-415	-	R3_4
440	440	R3_5
500 (2)	500 (2)	R0_8
550 (2)	550 (2)	R3_6
600 (2)(3)	600 (2)	R3_7

Note: In the cases below, select another coil according to the indicated values for Uc voltage.

- (1) RR..AME and RE..AME: 48 V ≤ Uc ≤ 250 V 50/60 Hz or DC
RR2500 ... RR5100: 48 V min
RE2500 ... RE5100: 48 V min.
- (2) RR..AMA and R..AMA: 440 V 50/60 Hz or DC, max.
- (3) RR800 ... RR5100: 550 V 50/60 Hz, max.
RR63..MT ... RR5100..MT: 550 V 50/60 Hz, max.
RR63..CC ... RR5100..CC: 550 V 50/60 Hz, max.

Blowout code table in DC circuit switching

Standard electromagnetic blowout coil (bidirectional)

Used to stretch and break the electric arc from contacts gap to the arc chute.

Blowout coil rating according to the operational current.

Rating	125 A	200 A	400 A	500 A	Code
63 A	A	A	A	A	<input type="checkbox"/> R
32	-	-	-	-	4R
40	170	260	400	550	5R
85	-	-	-	-	6R

Permanent magnets blowout (unidirectional)

If breaking current < 50% of contactor rating, the electromagnetic field remains too weak to blow the arc, therefore permanent magnets must be added.

Rating	Code
from 63 to 2100 A	<input type="checkbox"/> R
Permanent magnets blowout	7R

Pole polarization with permanent magnet

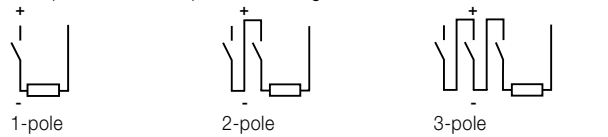

Auxiliary contacts

Main characteristics

For R63 ... R500 contactors

CARB, 1-pole auxiliary contact

- 1 N.O. auxiliary contact, generally used for "hold-in"
- I_{th} = 6 A
- Fitted on the left side.

CAOVE, 1-pole auxiliary contact

- 1 N.C. auxiliary contact, generally used for electrical interlocking (adjustable)
- I_{th} = 6 A
- Fitted on the right side.

CA12, 2-pole auxiliary contact blocks

Single block

CA12-1	1 N.O. + 1 N.C.
CA12-2	2 N.O.

Double block

CA12-11	2x CA12-1	= 2x (1 N.O. + 1 N.C.)
CA12-12	1x CA12-1 + 1x CA12-2	= (1 N.O. + 1 N.C.) + 2 N.O.
CA12-22	2x CA12-2	= 2x 2 N.O.

- I_{th} = 12 A
- Fitted on the upper part of the electro-magnet.

For CA12 contact limitation, please refer to Auxiliary contact fitting details table.

For R63 ... R5100 contactors

Small frame for R63 ... R500 contactors

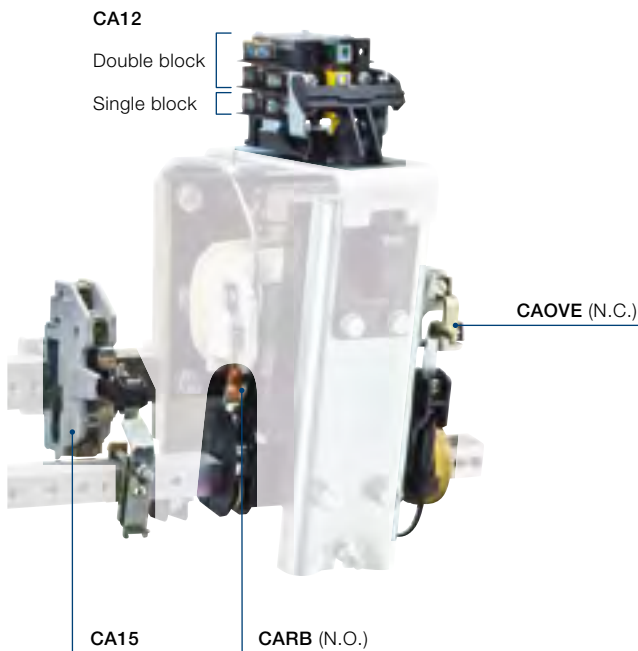

CA15, 1-pole adjustable auxiliary contacts

CA15-F	1 N.O.
CA15-O	1 N.C.

- For R63 ... R500 contactors: auxiliary contact are mounted between the main pole and the electro-magnet
- For R800 ... R5100 contactors: auxiliary contact are mounted on the auxiliary frame. If more CA15 are needed, they are mounted on the main frame
- I_{th} = 15 A.

Large frame for R800 ... R5100 contactors



Auxiliary contacts

Selection tables

Extra auxiliary contact code tables

F fixing dimension can change according to the number of CA15 auxiliary contacts. Refer to table below and "Dimensions" section.



Type				Code	Type				Code
RR, RE (63...500 A) (1)				R_□□_	RR, RE, RR..AME, RE..AME (≥ 800 A)				R_□□_
R..AMA (63...200 A) (2)					RR..AMA (63...200 A)				
CA12-1 N.O. + N.C.	CA12-2 2 x N.O.	CA15F N.O.	CA15O N.C.	CA15F N.O.	CA15O N.C.			CA15F N.O.	CA15O N.C.
-	-	-	-	R_00_	-	-		-	-
1	-	-	-	R_11_	-	1		1	R_01_
1	-	-	1	R_12_	-	2		2	R_02_
1	-	-	2	R_13_	-	3		3	R_03_
-	1	-	-	R_20_	-	4		4	R_04_
1	-	1	-	R_21_	1	-		-	R_10_
2	-	-	-	R_22_	1	1		1	R_11_
-	1	1	-	R_30_	1	2		2	R_12_
1	1	-	-	R_31_	2	-		-	R_20_
3	-	-	-	R_33_	2	1		1	R_21_
-	2	-	-	R_40_	2	2		2	R_22_
2	1	-	-	R_42_	3	-		-	R_30_
1	2	-	-	R_51_	3	1		1	R_31_
-	3	-	-	R_60_	3	2		2	R_32_
1	-	1	1	R_61_	3	3		3	R_33_
1	-	2	2	R_62_	4	-		-	R_40_
-	1	1	1	R_63_	4	1		1	R_41_
-	1	2	-	R_64_	4	2		2	R_42_
-	1	2	2	R_65_	4	3		3	R_43_
-	1	4	-	R_66_	5	-		-	R_50_
-	1	3	1	R_67_	5	1		1	R_51_
-	-	-	-	-	6	-		-	R_60_

(1) IORR63 ... IORR500 : code R_33_, R_42_, R_51_, R_60_ not allowed.

(2) IOR63..AMA ... IOR200..AMA : code R_22_, R_31_, R_33_, R_40_, R_42_, R_51_, R_60_ not allowed.

The above tables indicate the main auxiliary contact combinations. For other combinations, please consult us.

Auxiliary contact fitting details

Contactor types	Rating A	Auxiliary contacts fitted as standard		Additional auxiliary contacts without increasing dimension F (3)		
				CA15	CA12 Single block (incl. 2 contacts)	CA12 Double block (incl. 4 contacts)
IORR	800...5100	1 CA15-F	+ 1 CA15-O	+ 2 max.	-	-
IORE						
IORR..MT	63...500	1 CARB	+ 1 CAOVE	-	-	+ 1 max.
IORR..CC	800...5100	1 CA15-F	+ 1 CA15-O	+ 2 max.	-	-
IORE..MT	63...500	1 CARB	+ 1 CAOVE	-	+ 1 max.	+ 1 max.
	800...5100	1 CA15-F	+ 1 CA15-O	+ 2 max.	-	-
IORE..CC	63...500	1 CARB	+ 1 CAOVE	-	+ 1 max.	+ 1 max.
	800...5100	1 CA15-F	+ 1 CA15-O	+ 2 max.	-	-
IOR..AMA	63...200	1 CARB	-	-	+ 1 max.	-
IORR..AMA	63...200	1 CARB	-	-	-	-
IORR..AME	400...500	-	-	1 max.	-	-
IORE..AME	800...5100	-	-	5 max.	-	-
NORR..MT	63...200	1 CARB	+ 1 CAOVE	-	-	+ 1 max.
NORR..CC	800	1 CA15-F	+ 1 CA15-O	+ 2 max.	-	-
NORE..MT	63...200	1 CARB	+ 1 CAOVE	-	+ 1 max.	+ 1 max.
NORE..CC	800	1 CA15-F	+ 1 CA15-O	+ 2 max.	-	-

(3) More CA15 auxiliary contacts can be fitted with increasing dimension F. See fixing dimension F in "Dimensions" section.

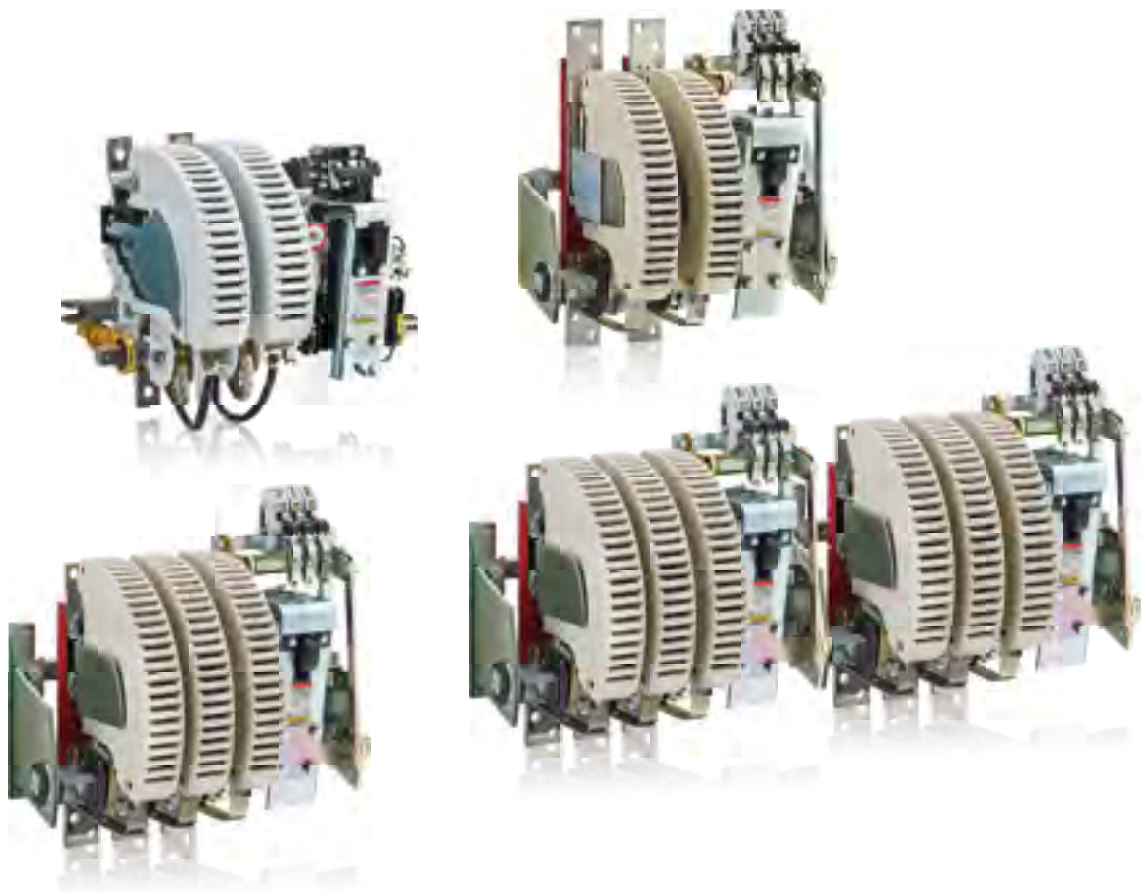

AC circuit switching

[Overview](#) 3/2

Ordering details

Power circuit up to 500 V AC

IORR	AC operated	3/4
IORE	DC operated	3/5

Power circuit up to 1000 V AC

IORR..MT	AC operated	3/6
IORE..MT	DC operated	3/7

Power circuit up to 500 V AC, with mechanical latching

IORR..AME	AC operated	3/8
IORE..AME	DC operated	3/9

Power circuit up to 1000 V AC, with latching

IORR..MT-AMA	AC operated	3/10
IORR..MT-AME	AC operated	3/10
IOR..MT-AMA	DC operated	3/11
IORE..MT-AME	DC operated	3/11

[Technical data](#) 3/12

[Type and order code for R contactors](#) 2/6



R contactors for AC circuit switching

3 Rated operational voltage U_e from 500 up to **1000 V AC**



Contactor type	AC control circuit	~	IORR63..MT	IORR125..MT	IORR200..MT	IORR400..MT	IORR500..MT	IORR800..MT
	DC control circuit	≡	IORE63..MT	IORE125..MT	IORE200..MT	IORE400..MT	IORE500..MT	IORE800..MT
Categories	U_e							
AC-1	at 40 °C	I_e	85 A	170 A	260 A	400 A	550 A	800 A
AC-3	690 V AC	I_e	85 A	160 A	260 A	400 A	550 A	800 A
	1000 V AC max.	I_e	56 A	105 A	180 A	280 A	380 A	580 A
AC-3	690 V AC	Power	80 kW	150 kW	240 kW	400 kW	540 kW	780 kW

Rated operational voltage U_e up to **500 V AC**

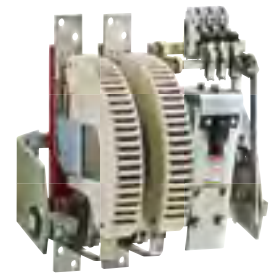

Contactor type	AC control circuit	~			IORR800	
	DC control circuit	≡			IORE800	
Categories	U_e					
AC-1	at 40 °C	I_e	From 85 A to 550 A, select above IOR...-MT			900 A
AC-3	380-415-440 V AC	I_e	-			800 A
	500 V AC max.	I_e	-			800 A
AC-3	400 V AC	Power	-			450 kW

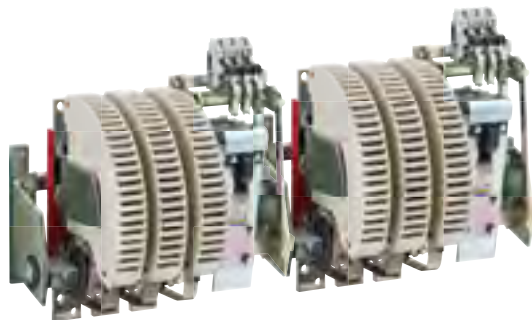
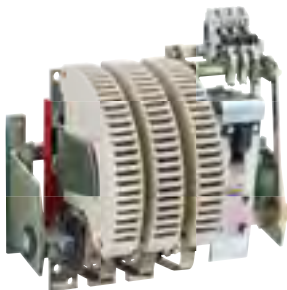

IORR1400..MT	IORR1700..MT	IORR2100..MT	IORR2500..MT	IORR3200..MT	IORR3800..MT	IORR4500..MT	IORR5100..MT
IORE1400..MT	IORE1700..MT	IORE2100..MT	IORE2500..MT	IORE3200..MT	IORE3800..MT	IORE4500..MT	IORE5100..MT

1250 A	1650 A	1850 A	2200 A	3000 A	3500 A	4000 A	4500 A
970 A	1170 A	1270 A	-	-	-	-	-
610 A	680 A	810 A	-	-	-	-	-
1000 kW	1200 kW	1300 kW	-	-	-	-	-

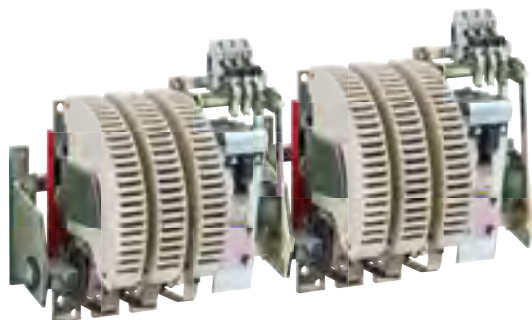
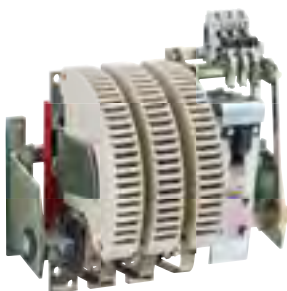
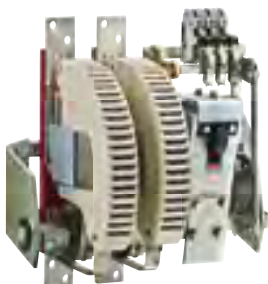

IORR1000	IORR1400	IORR1700	IORR2100	IORR2500	IORR3200	IORR3800	IORR4500	IORR5100
IORE1000	IORE1400	IORE1700	IORE2100	IORE2500	IORE3200	IORE3800	IORE4500	IORE5100

1000 A	1350 A	1650 A	2000 A	2400 A	3200 A	3800 A	4500 A	5000 A
800 A	1080 A	1260 A	1520 A	-	-	-	-	-
800 A	1080 A	1220 A	1340 A	-	-	-	-	-
450 kW	630 kW	750 kW	900 kW	-	-	-	-	-

IORR contactors

Power circuit up to 500 V AC

AC operated

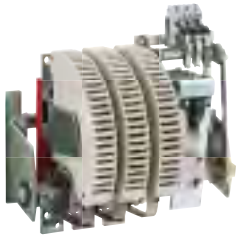

1SBC10A038FC0000

3

IORR800-30

Description

IORR contactors are used for controlling AC power circuits up to 500 V AC.

These contactors are designed with:

- variable number of poles according to the application
- control circuit: AC operated
- 1 N.O. and 1 N.C. auxiliary contacts available, as standard.

Ordering details

AC-3				AC-1		Number of poles	Rated control circuit voltage U _c (1)	Auxiliary contacts fitted (2)	Type	Order code	Weight Pkg (1 pce)				
Rated operational power		current		θ ≤ 40 °C											
380 V	440 V	500 V	≤ 440 V			V 50/60 Hz									
400 V	415 V		A	A											
kW	kW	kW	A	A						kg					
450	500	560	800	900	2	220...230	1 1	IORR800-20	FPL8615215R0006		38				
					3							1 1	IORR800-30	FPL8615315R0006	48
					4							1 1	IORR800-40	FPL8615415R0006	58
-	-	-	-	1000	2	220...230	1 1	IORR1000-20	FPL8715215R0006		38				
					3							1 1	IORR1000-30	FPL8715315R0006	48
					4							1 1	IORR1000-40	FPL8715415R0006	58
630	710	800	1080	1350	2	220...230	1 1	IORR1400-20	FPL6115215R0006		40				
					3							1 1	IORR1400-30	FPL6115315R0006	50
					4							1 1	IORR1400-40	FPL6115415R0006	63
750	800	900	1260	1650	2	220...230	1 1	IORR1700-20	FPL6215215R0006		44				
					3							1 1	IORR1700-30	FPL6215315R0006	56
					4							1 1	IORR1700-40	FPL6215415R0006	72
900	1000	1000	1520	2000	2	220...230	1 1	IORR2100-20	FPL6315215R0006		48				
					3							1 1	IORR2100-30	FPL6315315R0006	62
					4							1 1	IORR2100-40	FPL6315415R0006	78
-	-	-	-	2400	2	220...230	1 1	IORR2500-20	FPL6715215R0006		On request				
					3							1 1	IORR2500-30	FPL6715315R0006	
-	-	-	-	3200	2	220...230	1 1	IORR3200-20	FPL6515215R0006		On request				
					3							1 1	IORR3200-30	FPL6515315R0006	
-	-	-	-	3800	2	220...230	1 1	IORR3800-20	FPL6615215R0006		On request				
					3							1 1	IORR3800-30	FPL6615001R0006	
-	-	-	-	4500	2	220...230	1 1	IORR4500-20	FPL6815215R0006		On request				
					3							1 1	IORR4500-30	FPL6815001R0006	
-	-	-	-	5000	2	220...230	1 1	IORR5100-20	FPL6915001R0006		On request				
					3							1 1	IORR5100-30	FPL6915002R0006	

(1) Other control voltages see voltage code table.

(2) Other auxiliary contact arrangements, see auxiliary contact code table.

IORE contactors

Power circuit up to 500 V AC

DC operated

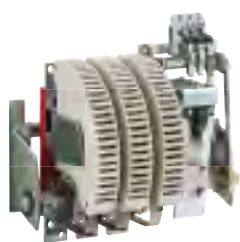

1SBC104038F0000

IORE800-30







Description

IORE contactors are used for controlling AC power circuits up to 500 V AC.

These contactors are designed with:

- variable number of poles according to the application
- control circuit: DC operated
- 1 N.O. and 1 N.C. auxiliary contacts available, as standard.

Ordering details

AC-3			AC-1		Number of poles	Rated control circuit voltage U _c (1)	Auxiliary contacts fitted (2)	Type	Order code	Weight Pkg (1 pce)
Rated operational power			current							
380 V	440 V	500 V	≤ 440 V		  	VDC	  			kg
kW	kW	kW	A	A						
450	500	560	800	900	2	220	1 1	IORE800-20	FPL8619215R0006	38
					3		1 1	IORE800-30	FPL8619315R0006	48
					4		1 1	IORE800-40	FPL8619415R0006	58
-	-	-	-	1000	2	220	1 1	IORE1000-20	FPL8719215R0006	38
					3		1 1	IORE1000-30	FPL8719315R0006	48
					4		1 1	IORE1000-40	FPL8719415R0006	58
630	710	800	1080	1350	2	220	1 1	IORE1400-20	FPL6119215R0006	40
					3		1 1	IORE1400-30	FPL6119315R0006	50
					4		1 1	IORE1400-40	FPL6119415R0006	63
750	800	900	1260	1650	2	220	1 1	IORE1700-20	FPL6219215R0006	44
					3		1 1	IORE1700-30	FPL6219315R0006	56
					4		1 1	IORE1700-40	FPL6219415R0006	72
900	1000	1000	1520	2000	2	220	1 1	IORE2100-20	FPL6319215R0006	48
					3		1 1	IORE2100-30	FPL6319315R0006	62
					4		1 1	IORE2100-40	FPL6319415R0006	78
-	-	-	-	2400	2	220	1 1	IORE2500-20	FPL6719215R0006	On request
					3		1 1	IORE2500-30	FPL6719315R0006	request
-	-	-	-	3200	2	220	1 1	IORE3200-20	FPL6519215R0006	On request
					3		1 1	IORE3200-30	FPL6519315R0006	request
-	-	-	-	3800	2	220	1 1	IORE3800-20	FPL6619215R0006	On request
					3		1 1	IORE3800-30	FPL6619001R0006	request
-	-	-	-	4500	2	220	1 1	IORE4500-20	FPL6819215R0006	On request
					3		1 1	IORE4500-30	FPL6819001R0006	request
-	-	-	-	5000	2	220	1 1	IORE5100-20	FPL6919001R0006	On request
					3		1 1	IORE5100-30	FPL6919002R0006	request

(1) Other control voltages see voltage code table.

(2) Other auxiliary contact arrangements, see auxiliary contact code table.



IORR..MT contactors

Power circuit up to 1000 V AC

AC operated

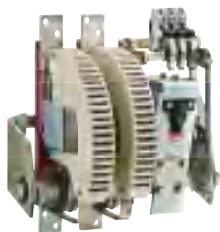

1SBC104041F0000

IORR1400-20-MT

Description

IORR..MT contactors are used for controlling AC power circuits from 500 up to 1000 V AC.

These contactors are designed with:

- variable number of poles according to the application
- control circuit: AC operated
- 1 N.O. and 1 N.C. auxiliary contacts available, as standard.

Ordering details

AC-3		AC-1		Number of poles	Rated control circuit voltage U _c (1)	Auxiliary contacts fitted (2)	Type	Order code	Weight
Rated operational power (3)		current							
690 V	1000 V	≤ 690 V	θ ≤ 40 °C						Pkg (1 pce)
kW	kW	A	A						
80	80	85	85	2	220...230	1 1	IORR63-20-MT	FPL7125216R0006	4.2
				3		1 1	IORR63-30-MT	FPL7125386R0006	5.2
				4		1 1	IORR63-40-MT	FPL7125416R0006	6.2
150	150	160	170	2	220...230	1 1	IORR125-20-MT	FPL7425215R0006	6.2
				3		1 1	IORR125-30-MT	FPL7425315R0006	8.2
				4		1 1	IORR125-40-MT	FPL7425415R0006	10.2
240	250	260	260	2	220...230	1 1	IORR200-20-MT	FPL7625215R0006	9.6
				3		1 1	IORR200-30-MT	FPL7625315R0006	12.6
				4		1 1	IORR200-40-MT	FPL7625415R0006	15.6
400	400	400	400	2	220...230	1 1	IORR400-20-MT	FPL9425215R0006	19.2
				3		1 1	IORR400-30-MT	FPL9425315R0006	25
				4		1 1	IORR400-40-MT	FPL9425415R0006	30.8
540	550	550	550	2	220...230	1 1	IORR500-20-MT	FPL8325215R0006	19.7
				3		1 1	IORR500-30-MT	FPL8325315R0006	25.5
				4		1 1	IORR500-40-MT	FPL8325415R0006	31.3
780	850	800	800	2	220...230	1 1	IORR800-20-MT	FPL8625215R0006	40
				3		1 1	IORR800-30-MT	FPL8625315R0006	51
				4		1 1	IORR800-40-MT	FPL8625415R0006	62
1000	900	970	1250	2	220...230	1 1	IORR1400-20-MT	FPL6125215R0006	42
				3		1 1	IORR1400-30-MT	FPL6125315R0006	52
				4		1 1	IORR1400-40-MT	FPL6125415R0006	65
1200	1000	1170	1650	2	220...230	1 1	IORR1700-20-MT	FPL6225215R0006	47
				3		1 1	IORR1700-30-MT	FPL6225315R0006	61
				4		1 1	IORR1700-40-MT	FPL6225415R0006	74
1300	1200	1270	1850	2	220...230	1 1	IORR2100-20-MT	FPL6325215R0006	52
				3		1 1	IORR2100-30-MT	FPL6325315R0006	68
				4		1 1	IORR2100-40-MT	FPL6325415R0006	82
-	-	-	2200	2	220...230	1 1	IORR2500-20-MT	FPL6725215R0006	71
				3		1 1	IORR2500-30-MT	FPL6725315R0006	On request
				4		1 1	IORR2500-40-MT	FPL6725415R0006	
-	-	-	3000	2	220...230	1 1	IORR3200-20-MT	FPL6525215R0006	83
				3		1 1	IORR3200-30-MT	FPL6525315R0006	On request
-	-	-	3500	2	220...230	1 1	IORR3800-20-MT	FPL6625215R0006	95
				3		1 1	IORR3800-30-MT	FPL6625001R0006	On request
-	-	-	4000	2	220...230	1 1	IORR4500-20-MT	FPL6825215R0006	On request
				3		1 1	IORR4500-30-MT	FPL6825002R0006	
-	-	-	4500	2	220...230	1 1	IORR5100-20-MT	FPL6925001R0006	On request
				3		1 1	IORR5100-30-MT	FPL6925002R0006	

(1) Other control voltages see voltage code table.

(2) Other auxiliary contact arrangements, see auxiliary contact code table.

(3) Power circuit above 1000 V AC, please consult us.

IORE..MT contactors

Power circuit up to 1000 V AC

DC operated

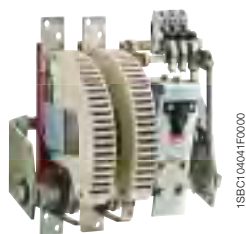

IORE1400-20-MT

1SBC104011F0000

Description

IORE..MT contactors are used for controlling AC power circuits from 500 up to 1000 V AC.

These contactors are designed with:

- variable number of poles according to the application
- control circuit: DC operated
- 1 N.O. and 1 N.C. auxiliary contacts available, as standard.

Ordering details

AC-3			AC-1		Number of poles	Rated operational power (3)	Rated operational current	Rated control circuit voltage U _c (1)	Auxiliary contacts fitted (2)	Type	Order code	Weight
690 V	1000 V	≤ 690 V	θ ≤ 40 °C	V DC								
kW	kW	A	A									kg
80	80	85	85	2	220				1 1	IORE63-20-MT	FPL7129216R0006	4.2
				3					1 1	IORE63-30-MT	FPL7129386R0006	5.2
				4					1 1	IORE63-40-MT	FPL7129416R0006	6.2
150	150	160	170	2	220				1 1	IORE125-20-MT	FPL7429215R0006	6.2
				3					1 1	IORE125-30-MT	FPL7429315R0006	8.2
				4					1 1	IORE125-40-MT	FPL7429415R0006	10.2
240	250	260	260	2	220				1 1	IORE200-20-MT	FPL7629215R0006	9.6
				3					1 1	IORE200-30-MT	FPL7629315R0006	12.6
				4					1 1	IORE200-40-MT	FPL7629415R0006	15.6
400	400	400	400	2	220				1 1	IORE400-20-MT	FPL9429215R0006	19.2
				3					1 1	IORE400-30-MT	FPL9429315R0006	25
				4					1 1	IORE400-40-MT	FPL9429415R0006	30.8
540	550	550	550	2	220				1 1	IORE500-20-MT	FPL8329215R0006	19.7
				3					1 1	IORE500-30-MT	FPL8329315R0006	25.5
				4					1 1	IORE500-40-MT	FPL8329415R0006	31.3
780	850	800	800	2	220				1 1	IORE800-20-MT	FPL8629215R0006	40
				3					1 1	IORE800-30-MT	FPL8629315R0006	51
				4					1 1	IORE800-40-MT	FPL8629415R0006	62
1000	900	970	1250	2	220				1 1	IORE1400-20-MT	FPL6129215R0006	42
				3					1 1	IORE1400-30-MT	FPL6129315R0006	52
				4					1 1	IORE1400-40-MT	FPL6129415R0006	65
1200	1000	1170	1650	2	220				1 1	IORE1700-20-MT	FPL6229215R0006	47
				3					1 1	IORE1700-30-MT	FPL6229315R0006	61
				4					1 1	IORE1700-40-MT	FPL6229415R0006	74
1300	1200	1270	1850	2	220				1 1	IORE2100-20-MT	FPL6329215R0006	52
				3					1 1	IORE2100-30-MT	FPL6329315R0006	68
				4					1 1	IORE2100-40-MT	FPL6329415R0006	82
-	-	-	2200	2	220				1 1	IORE2500-20-MT	FPL6729215R0006	71
				3					1 1	IORE2500-30-MT	FPL6729315R0006	On request
				4					1 1	IORE2500-40-MT	FPL6729415R0006	On request
-	-	-	3000	2	220				1 1	IORE3200-20-MT	FPL6529215R0006	83
				3					1 1	IORE3200-30-MT	FPL6529315R0006	On request
-	-	-	3500	2	220				1 1	IORE3800-20-MT	FPL6629215R0006	95
				3					1 1	IORE3800-30-MT	FPL6629001R0006	On request
-	-	-	4000	2	220				1 1	IORE4500-20-MT	FPL6829215R0006	On request
				3					1 1	IORE4500-30-MT	FPL6829001R0006	On request
-	-	-	4500	2	220				1 1	IORE5100-20-MT	FPL6929001R0006	On request
				3					1 1	IORE5100-30-MT	FPL6929002R0006	On request

(1) Other control voltages see voltage code table.

(2) Other auxiliary contact arrangements, see auxiliary contact code table.

(3) Power circuit above 1000 V AC, please consult us.

IORR..AME contactors

Power circuit up to 500 V AC, with mechanical latching

AC operated

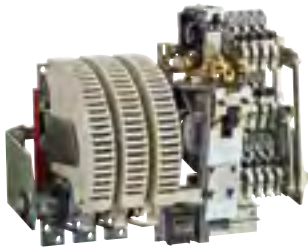

15BC10404F000

IORR800-30-AME

Description

IORR..AME contactors are used for controlling AC power circuits up to 500 V AC.

These contactors are designed with:

- mechanical latching
- variable number of poles according to the application
- control circuit: AC operated
- 1 N.O. and 1 N.C. auxiliary contacts available.

Ordering details

AC-3				AC-1		Nb of poles	Rated control circuit voltage Uc (1)	Auxiliary contacts fitted (2)	Type	Order code	Weight Pkg (1 pce)
Rated operational power		current		A	A						
380 V	440 V	500 V	≤ 440 V			θ ≤ 40 °C		V 50/60 Hz	I L		
kW	kW	kW	A								
450	500	560	800	900	2	220...230	1 1	IORR800-20-AME	FPL8615225R0116	48	
					3		1 1	IORR800-30-AME	FPL8615325R0116	58	
					4		1 1	IORR800-40-AME	FPL8615425R0116	68	
-	-	-	-	1000	2	220...230	1 1	IORR1000-20-AME	FPL8715225R0116	48	
					3		1 1	IORR1000-30-AME	FPL8715325R0116	58	
					4		1 1	IORR1000-40-AME	FPL8715425R0116	68	
630	710	800	1080	1350	2	220...230	1 1	IORR1400-20-AME	FPL6115225R0116	50	
					3		1 1	IORR1400-30-AME	FPL6115325R0116	60	
					4		1 1	IORR1400-40-AME	FPL6115425R0116	73	
750	800	900	1260	1650	2	220...230	1 1	IORR1700-20-AME	FPL6215225R0116	54	
					3		1 1	IORR1700-30-AME	FPL6215325R0116	66	
					4		1 1	IORR1700-40-AME	FPL6215425R0116	82	
900	1000	1000	1520	2000	2	220...230	1 1	IORR2100-20-AME	FPL6315225R0116	58	
					3		1 1	IORR2100-30-AME	FPL6315325R0116	72	
					4		1 1	IORR2100-40-AME	FPL6315425R0116	88	
-	-	-	-	2400	2	220...230	1 1	IORR2500-20-AME	FPL6715225R0116	On request	
					3		1 1	IORR2500-30-AME	FPL6715325R0116	On request	
-	-	-	-	3200	2	220...230	1 1	IORR3200-20-AME	FPL6515225R0116	On request	
					3		1 1	IORR3200-30-AME	FPL6515325R0116	On request	
-	-	-	-	3800	2	220...230	1 1	IORR3800-20-AME	FPL6615225R0116	On request	
-	-	-	-	4500	2	220...230	1 1	IORR4500-20-AME	FPL6815225R0116	On request	

(1) Other control voltages see voltage code table.

(2) Other auxiliary contact arrangements, see auxiliary contact code table.

IORE..AME contactors

Power circuit up to 500 V AC, with mechanical latching

DC operated

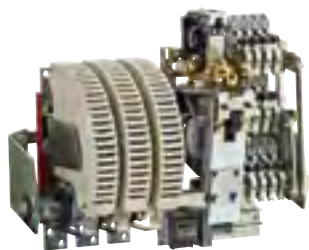

IORE800-30-AME

15BC104044F000

Description

IORE..-AME contactors are used for controlling AC power circuits up to 500 V AC.

These contactors are designed with:

- mechanical latching
- variable number of poles according to the application
- control circuit: DC operated
- 1 N.O. and 1 N.C. auxiliary contacts available.

Ordering details

AC-3					AC-1	Nb of poles	Rated control circuit voltage U _c (1)	Auxiliary contacts fitted (2)	Type	Order code	Weight
Rated operational power		current			θ ≤ 40 °C						
380 V	440 V	500 V	≤ 440 V	A		A	Pkg (1 pce)				
400 V	415 V										
450	500	560	800	900	2	220	1 1	IORE800-20-AME	FPL8619225R0116	48	
					3		1 1	IORE800-30-AME	FPL8619325R0116	58	
					4		1 1	IORE800-40-AME	FPL8619425R0116	68	
-	-	-	-	1000	2	220	1 1	IORE1000-20-AME	FPL8719225R0116	48	
					3		1 1	IORE1000-30-AME	FPL8719325R0116	58	
					4		1 1	IORE1000-40-AME	FPL8719425R0116	68	
630	710	800	1080	1350	2	220	1 1	IORE1400-20-AME	FPL6119225R0116	50	
					3		1 1	IORE1400-30-AME	FPL6119325R0116	60	
					4		1 1	IORE1400-40-AME	FPL6119425R0116	73	
750	800	900	1260	1650	2	220	1 1	IORE1700-20-AME	FPL6219225R0116	54	
					3		1 1	IORE1700-30-AME	FPL6219325R0116	66	
					4		1 1	IORE1700-40-AME	FPL6219425R0116	82	
900	1000	1000	1520	2000	2	220	1 1	IORE2100-20-AME	FPL6319225R0116	58	
					3		1 1	IORE2100-30-AME	FPL6319325R0116	72	
					4		1 1	IORE2100-40-AME	FPL6319425R0116	88	
-	-	-	-	2400	2	220	1 1	IORE2500-20-AME	FPL6719225R0116	On request	
					3		1 1	IORE2500-30-AME	FPL6719325R0116	On request	
-	-	-	-	3200	2	220	1 1	IORE3200-20-AME	FPL6519225R0116	On request	
					3		1 1	IORE3200-30-AME	FPL6519325R0116	On request	
-	-	-	-	3800	2	220	1 1	IORE3800-20-AME	FPL6619225R0116	On request	
										On request	
-	-	-	-	4500	2	220	1 1	IORE4500-20-AME	FPL6819225R0116	On request	

(1) Other control voltages see voltage code table.

(2) Other auxiliary contact arrangements, see auxiliary contact code table.



IORR..MT-AMA and IORR..MT-AME contactors

Power circuit up to 1000 V AC, with latching AC operated

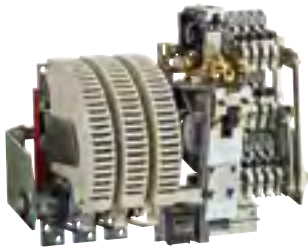

IORR800-30-MT-AME

1SBC10044R0000

Description

IORR..MT-AMA and IORR..MT-AME contactors are used for controlling AC power circuits from 500 up to 1000 V AC.

These contactors are designed with:

- magnetical latching, AMA types
- mechanical latching, AME types
- variable number of poles according to the application
- control circuit: AC operated
- 1 N.O. auxiliary contact available for AMA version, as standard.
- 1 N.O. and 1 N.C. auxiliary contacts available for AME version.

Ordering details

AC-3		AC-1		Number of poles	Rated control circuit voltage U _c (1)	Auxiliary contacts fitted (2)	Type	Order code	Weight
Rated operational power (3)	current	current	θ ≤ 40 °C						
690 V	1000 V	≤ 690 V			V 50/60 Hz				kg
kW	kW	A	A						
Magnetical latching									
80	80	85	85	2	220...230	1 0	IORR63-20-MT-AMA	FPL7125236R0006	3.9
				3		1 0	IORR63-30-MT-AMA	FPL7125336R0006	4.9
				4		1 0	IORR63-40-MT-AMA	FPL7125436R0006	5.9
150	150	160	170	2	220...230	1 0	IORR125-20-MT-AMA	FPL7425235R0006	5.9
				3		1 0	IORR125-30-MT-AMA	FPL7425335R0006	7.9
				4		1 0	IORR125-40-MT-AMA	FPL7425435R0006	9.9
240	250	260	260	2	220...230	1 0	IORR200-20-MT-AMA	FPL7625235R0006	9.2
				3		1 0	IORR200-30-MT-AMA	FPL7625335R0006	12.2
				4		1 0	IORR200-40-MT-AMA	FPL7625435R0006	15.2
Mechanical latching									
400	400	400	400	2	220...230	1 1	IORR400-20-MT-AME	FPL9425225R0116	24.2
				3		1 1	IORR400-30-MT-AME	FPL9425325R0116	30
540	550	550	550	2	220...230	1 1	IORR500-20-MT-AME	FPL8325225R0116	24.2
				3		1 1	IORR500-30-MT-AME	FPL8325325R0116	30
780	850	800	800	2	220...230	1 1	IORR800-20-MT-AME	FPL8625225R0116	50
				3		1 1	IORR800-30-MT-AME	FPL8625325R0116	61
1000	900	970	1250	2	220...230	1 1	IORR1400-20-MT-AME	FPL6125225R0116	52
				3		1 1	IORR1400-30-MT-AME	FPL6125325R0116	62
1200	1000	1170	1650	2	220...230	1 1	IORR1700-20-MT-AME	FPL6225225R0116	57
				3		1 1	IORR1700-30-MT-AME	FPL6225325R0116	71
1300	1200	1270	1850	2	220...230	1 1	IORR2100-20-MT-AME	FPL6325225R0116	62
				3		1 1	IORR2100-30-MT-AME	FPL6325325R0116	78
-	-	-	2200	2	220...230	1 1	IORR2500-20-MT-AME	FPL6725225R0116	On request
				3		1 1	IORR2500-30-MT-AME	FPL6725325R0116	On request
-	-	-	3000	2	220...230	1 1	IORR3200-20-MT-AME	FPL6525225R0116	On request
				3		1 1	IORR3200-30-MT-AME	FPL6525325R0116	On request
-	-	-	3500	2	220...230	1 1	IORR3800-20-MT-AME	FPL6625225R0116	On request
				3		1 1	IORR3800-30-MT-AME	FPL6625325R0116	On request
-	-	-	4000	2	220...230	1 1	IORR4500-20-MT-AME	FPL6825225R0116	On request

(1) Other control voltages see voltage code table.

(2) Other auxiliary contact arrangements, see auxiliary contact code table.

(3) Power circuit above 1000 V AC, please consult us.

IOR..MT-AMA and IORE..MT-AME contactors

Power circuit up to 1000 V AC, with latching DC operated

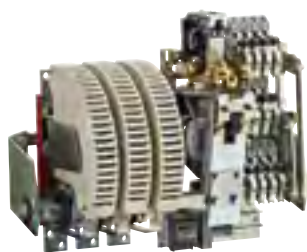

IORE800-30-MT-AME

15BCT104044F0000

Description

IOR..MT-AMA and IORE..MT-AME contactors are used for controlling AC power circuits from 500 up to 1000 V AC.

These contactors are designed with:

- magnetical latching, AMA types
- mechanical latching, AME types
- variable number of poles according to the application
- control circuit: DC operated
- 1 N.O. auxiliary contact available for AMA version, as standard.
- 1 N.O. and 1 N.C. auxiliary contacts available for AME version.

Ordering details

AC-3		AC-1		Number of poles	Rated control circuit voltage U _c ⁽¹⁾	Auxiliary contacts fitted ⁽²⁾	Type	Order code	Weight	
Rated operational power ⁽³⁾		current								V DC
690 V	1000 V	≤ 690 V	θ ≤ 40 °C						Pkg (1 pce)	
kW	kW	A	A							
Magnetical latching										
80	80	85	85	2	220	1 0	IOR63-20-MT-AMA	FPL7121236R0006		3.9
				3		1 0	IOR63-30-MT-AMA	FPL7121336R0006		4.9
				4		1 0	IOR63-40-MT-AMA	FPL7121436R0006		5.9
150	150	160	170	2	220	1 0	IOR125-20-MT-AMA	FPL7421235R0006		5.9
				3		1 0	IOR125-30-MT-AMA	FPL7421335R0006		7.9
				4		1 0	IOR125-40-MT-AMA	FPL7421435R0006		9.9
240	250	260	260	2	220	1 0	IOR200-20-MT-AMA	FPL7621235R0006		9.2
				3		1 0	IOR200-30-MT-AMA	FPL7621335R0006		12.2
				4		1 0	IOR200-40-MT-AMA	FPL7621435R0006		15.2
Mechanical latching										
400	400	400	400	2	220	1 1	IORE400-20-MT-AME	FPL9425925R0116		24.2
				3		1 1	IORE400-30-MT-AME	FPL9429325R0116		30
540	550	550	550	2	220	1 1	IORE500-20-MT-AME	FPL8329225R0116		24.2
				3		1 1	IORE500-30-MT-AME	FPL8329325R0116		30
780	850	800	800	2	220	1 1	IORE800-20-MT-AME	FPL8629225R0116		50
				3		1 1	IORE800-30-MT-AME	FPL8629325R0116		61
1000	900	970	1250	2	220	1 1	IORE1400-20-MT-AME	FPL6129225R0116		52
				3		1 1	IORE1400-30-MT-AME	FPL6129325R0116		62
1200	1000	1170	1650	2	220	1 1	IORE1700-20-MT-AME	FPL6229225R0116		57
				3		1 1	IORE1700-30-MT-AME	FPL6229325R0116		71
1300	1200	1270	1850	2	220	1 1	IORE2100-20-MT-AME	FPL6329225R0116		62
				3		1 1	IORE2100-30-MT-AME	FPL6329325R0116		78
-	-	-	2200	2	220	1 1	IORE2500-20-MT-AME	FPL6729225R0116		On request
				3		1 1	IORE2500-30-MT-AME	FPL6729325R0116		On request
-	-	-	3000	2	220	1 1	IORE3200-20-MT-AME	FPL6529225R0116		On request
				3		1 1	IORE3200-30-MT-AME	FPL6529325R0116		On request
-	-	-	3500	2	220	1 1	IORE3800-20-MT-AME	FPL6629225R0116		On request
				3		1 1	IORE3800-30-MT-AME	FPL6629325R0116		On request
-	-	-	4000	2	220	1 1	IORE4500-20-MT-AME	FPL6829225R0116		On request

(1) Other control voltages see voltage code table.

(2) Other auxiliary contact arrangements, see auxiliary contact code table.



(3) Power circuit above 1000 V AC, please consult us.



IORR800 ... IORR2100 and IORE800 ... IORE2100 contactors

Technical data

Main pole - Utilization characteristics according to IEC

Contactor types	AC operated	IORR800	IORR1000	IORR1400	IORR1700	IORR2100
	DC operated	IORE800	IORE1000	IORE1400	IORE1700	IORE2100
Standards	IEC 60947-1 / 60947-4-1 and EN 60947-1 / 60947-4-1					
Rated operational voltage U_e max.	500 V					
Rated frequency (without derating)	25...60 Hz (for > 60...400 Hz please consult us)					
Number of poles	2...4					
Conventional free-air thermal current I_{th}						
acc. to IEC 60947-4-1, open contactors, $\theta \leq 40^\circ\text{C}$		1000 A	1100 A	1400 A	1700 A	2100 A
With conductor cross-sectional area		600 mm ²	600 mm ²	1000 mm ²	1500 mm ²	2000 mm ²
AC-1 Utilization category						
For air temperature close to contactor						
I_e / Rated operational current AC-1	$\theta \leq 40^\circ\text{C}$	900 A	1000 A	1350 A	1650 A	2000 A
U _e max. $\leq 500\text{ V}$, 50/60 Hz	$\theta \leq 55^\circ\text{C}$	840 A	930 A	1180 A	1450 A	1750 A
	$\theta \leq 70^\circ\text{C}$	720 A	800 A	1000 A	1250 A	1500 A
With conductor cross-sectional area		600 mm ²	600 mm ²	1000 mm ²	1500 mm ²	2000 mm ²
AC-3 Utilization category						
For air temperature close to contactor $\theta \leq 55^\circ\text{C}$						
I_e / Max. rated operational current AC-3						
	380-415-440 V	800 A	-	1080 A	1260 A	1520 A
	500 V	800 A	-	1080 A	1220 A	1340 A
Rated operational power AC-3						
	380-415 V	450 kW	-	630 kW	750 kW	900 kW
	440 V	500 kW	-	710 kW	800 kW	1000 kW
	500 V	560 kW	-	800 kW	900 kW	1000 kW
Rated making capacity AC-3	10 x I _e AC-3 acc. to IEC 60947-4-1					
Rated breaking capacity AC-3	8 x I _e AC-3 acc. to IEC 60947-4-1					
Short-circuit protection device for contactors						
without thermal overload relay - Motor protection excluded						
Circuit breaker		1250 A	1250 A	1600 A	2000 A	2500 A
Rated short-time withstand current I_{cw}	1 s	9000 A	9000 A	11000 A	13000 A	15000 A
at 40 °C ambient temperature,	10 s	8000 A	8000 A	9000 A	11000 A	12200 A
in free air from a cold state	30 s	4000 A	4000 A	5000 A	6000 A	7000 A
	1 min	3000 A	3000 A	3700 A	4400 A	5000 A
	15 min	1600 A	1600 A	2000 A	2400 A	2800 A
Maximum breaking capacity						
cos $\phi = 0,35$	at 500 V	6400 A	6400 A	10000 A	13500 A	
Maximum making capacity		14000 A	14000 A	19000 A	21000 A	24000 A
Dynamical withstand of pole		14000 A	14000 A	19000 A	21000 A	24000 A
Impedance per pole		0.18 m Ω	0.18 m Ω	0.10 m Ω	0.09 m Ω	0.08 m Ω
Maximum electrical switching frequency	AC-1	300 cycles/h	-	150 cycles/h	120 cycles/h	
	AC-3	300 cycles/h	-	150 cycles/h	120 cycles/h	
	AC-4	150 cycles/h	-	-	-	
Mechanical durability						
Number of operating cycles		5 millions cycles		2 millions cycles		
Max. switching frequency		1200 cycles/h		600 cycles/h		

Note: These characteristics are suitable for IOR..AME contactor versions (except for mechanical durability = 0.2 millions of operating cycles).

IORR2500 ... IORR5100 and IORE2500 ... IORE5100 contactors

Technical data

Main pole - Utilization characteristics according to IEC

Contactor types	AC operated	IORR2500	IORR3200	IORR3800	IORR4500	IORR5100
	DC operated	IORE2500	IORE3200	IORE3800	IORE4500	IORE5100
Standards	IEC 60947-1 / 60947-4-1 and EN 60947-1 / 60947-4-1					
Rated operational voltage U_e max.	500 V					
Rated frequency (without derating)	25...60 Hz (for > 60...400 Hz please consult us)					
Number of poles	2...4					
Conventional free-air thermal current I_{th} acc. to IEC 60947-4-1, open contactors, $\theta \leq 40\text{ °C}$ With conductor cross-sectional area	2500 A 2000 mm ²	3200 A 3000 mm ²	3800 A 3000 mm ²	4500 A 4000 mm ²	5000 A 4000 mm ²	
AC-1 Utilization category For air temperature close to contactor I_e / Rated operational current AC-1 U _e max. $\leq 500\text{ V}$, 50/60 Hz	$\theta \leq 40\text{ °C}$ $\theta \leq 55\text{ °C}$ $\theta \leq 70\text{ °C}$	2400 A 2100 A 1760 A	3200 A 2810 A 2350 A	3800 A 3330 A 2790 A	4500 A 3950 A 3300 A	5000 A 4390 A 3670 A
With conductor cross-sectional area	2000 mm ² 3000 mm ² 3000 mm ² 4000 mm ² 4000 mm ²					
Rated making capacity AC-1	1.5 x I _e acc. to IEC 60947-4-1					
Rated breaking capacity AC-1	1.5 x I _e acc. to IEC 60947-4-1					
AC-3 Utilization category For air temperature close to contactor $\theta \leq 55\text{ °C}$ I_e / Max. rated operational current AC-3						
	380-415-440 V	Please consult us				
	500 V	Please consult us				
Short-circuit protection device for contactors without thermal overload relay - Motor protection excluded Circuit breaker		-	-	-	-	-
Rated short-time withstand current I_{cw} at 40 °C ambient temperature, in free air from a cold state	1 s 10 s 30 s 1 min 15 min	20000 A 15000 A 8000 A 6000 A 3000 A	21000 A 18000 A 10000 A 7000 A 4000 A	24000 A 19000 A 11000 A 7500 A 4500 A	28000 A 21000 A 12000 A 8000 A 5000 A	30000 A 24000 A 13000 A 9000 A 5500 A
Maximum making capacity	24000 A 26000 A 29000 A 32000 A 32000 A					
Dynamical withstand of pole	24000 A 26000 A 29000 A 32000 A 32000 A					
Impedance per pole	0.05 m Ω 0.045 m Ω 0.040 m Ω 0.030 m Ω 0.027 m Ω					
Maximum electrical switching frequency	AC-1	60 cycles/h		40 cycles/h		
Mechanical durability						
Number of operating cycles	2 millions cycles		1 million cycles			
Max. switching frequency	600 cycles/h		300 cycles/h			



Note: These characteristics are suitable for IOR..AME contactor versions (except for mechanical durability = 0.2 millions of operating cycles).



IORR63..MT ... IORR500..MT and IORE63..MT ... IORE500..MT contactors

Technical data

Main pole - Utilization characteristics according to IEC



Contactor types	AC operated	IORR63..MT	IORR125..MT	IORR200..MT	IORR400..MT	IORR500..MT
	DC operated	IORE63..MT	IORE125..MT	IORE200..MT	IORE400..MT	IORE500..MT
Standards		IEC 60947-1 / 60947-4-1 and EN 60947-1 / 60947-4-1				
Rated operational voltage U_e max.		1000 V				
Rated frequency (without derating)		25...60 Hz (for > 60...400 Hz please consult us)				
Number of poles		2...4				
Conventional free-air thermal current I_{th}						
acc. to IEC 60947-4-1, open contactors, $\theta \leq 40^\circ\text{C}$		85 A	170 A	275 A	400 A	550 A
With conductor cross-sectional area		25 mm ²	70 mm ²	150 mm ²	240 mm ²	400 mm ²
AC-1 Utilization category						
For air temperature close to contactor						
I_e / Rated operational current AC-1	$\theta \leq 40^\circ\text{C}$	85 A	170 A	260 A	400 A	550 A
U _e max. $\leq 1000\text{ V}$, 50/60 Hz	$\theta \leq 55^\circ\text{C}$	76 A	150 A	230 A	350 A	490 A
	$\theta \leq 70^\circ\text{C}$	68 A	135 A	205 A	300 A	400 A
With conductor cross-sectional area		25 mm ²	70 mm ²	150 mm ²	240 mm ²	400 mm ²
AC-3 Utilization category						
For air temperature close to contactor $\theta \leq 55^\circ\text{C}$						
I_e / Max. rated operational current AC-3						
	690 V	85 A	160 A	260 A	400 A	550 A
	1000 V	56 A	105 A	180 A	280 A	380 A
Rated operational power AC-3						
	690 V	80 kW	150 kW	240 kW	400 kW	540 kW
	1000 V	80 kW	150 kW	250 kW	400 kW	550 kW
Rated making capacity AC-3		10 x I _e AC-3 acc. to IEC 60947-4-1				
Rated breaking capacity AC-3		8 x I _e AC-3 acc. to IEC 60947-4-1				
Short-circuit protection device for contactors						
without thermal overload relay - Motor protection excluded						
U _e $\leq 1000\text{ V AC}$ - gG type fuse		100 A	200 A	315 A	500 A	630 A
U _e $\leq 1000\text{ V AC}$ - L type fuse		-	-	-	-	-
Rated short-time withstand current I_{cw}						
at 40 °C ambient temperature,	1 s	1150 A	2250 A	3800 A	6000 A	8400 A
in free air from a cold state	10 s	680 A	1280 A	2080 A	3200 A	4400 A
	30 s	310 A	680 A	1040 A	1600 A	2200 A
	1 min	230 A	450 A	730 A	1200 A	1680 A
	15 min	120 A	250 A	390 A	600 A	840 A
Maximum breaking capacity						
cos $\phi = 0.45$	at 690 V	680 A	1280 A	2100 A	4480 A	4480 A
(cos $\phi = 0.35$ for I _e > 100 A)	at 1000 V	450 A	850 A	1450 A	3050 A	3050 A
Maximum making capacity		1300 A	2400 A	4000 A	7000 A	9000 A
Dynamical withstand of pole		1400 A	2500 A	4500 A	8000 A	10000 A
Impedance per pole		1.8 m Ω	1.20 m Ω	0.60 m Ω	0.40 m Ω	0.35 m Ω
Maximum electrical switching frequency						
	AC-1	300 cycles/h				
	AC-3	300 cycles/h				
	AC-4	150 cycles/h				
Mechanical durability						
Number of operating cycles		5 millions cycles				
Max. switching frequency		1200 cycles/h				

Note: These characteristics are suitable for IOR..MT-AMA and IOR..MT-AME contactors with latching versions (except for mechanical durability = 0.2 millions of operating cycles).

IORR800..MT ... IORR2100..MT and IORE800..MT ... IORE2100..MT contactors

Technical data

Main pole - Utilization characteristics according to IEC

Contactor types	AC operated	IORR800..MT	IORR1400..MT	IORR1700..MT	IORR2100..MT
	DC operated	IORE800..MT	IORE1400..MT	IORE1700..MT	IORE2100..MT
Standards	IEC 60947-1 / 60947-4-1 and EN 60947-1 / 60947-4-1				
Rated operational voltage Ue max.	1000 V				
Rated frequency (without derating)	25...60 Hz (for > 60...400 Hz please consult us)				
Number of poles	2...4				
Conventional free-air thermal current Ith acc. to IEC 60947-4-1, open contactors, $\theta \leq 40\text{ }^\circ\text{C}$		800 A	1300 A	1700 A	1850 A
With conductor cross-sectional area		500 mm ²	1000 mm ²	1500 mm ²	1500 mm ²
AC-1 Utilization category For air temperature close to contactor					
Ie / Rated operational current AC-1 Ue max. $\leq 690\text{ V}$, 50/60 Hz	$\theta \leq 40\text{ }^\circ\text{C}$	800 A	1250 A	1650 A	1850 A
	$\theta \leq 55\text{ }^\circ\text{C}$	740 A	1100 A	1450 A	1620 A
	$\theta \leq 70\text{ }^\circ\text{C}$	640 A	900 A	1250 A	1400 A
Ie / Rated operational current AC-1 Ue max. $\leq 1000\text{ V}$, 50/60 Hz With conductor cross-sectional area	$\theta \leq 40\text{ }^\circ\text{C}$	800 A	1220 A	1360 A	1620 A
		500 mm ²	1000 mm ²	1500 mm ²	1500 mm ²
AC-3 Utilization category For air temperature close to contactor $\theta \leq 55\text{ }^\circ\text{C}$					
Ie / Max. rated operational current AC-3					
	690 V	800 A	970 A	1170 A	1270 A
	1000 V	580 A	610 A	680 A	810 A
Rated operational power AC-3					
	690 V	780 kW	1000 kW	1200 kW	1300 kW
	1000 V	850 kW	900 kW	1000 kW	1200 kW
Rated making capacity AC-3	10 x Ie AC-3 acc. to IEC 60947-4-1				
Rated breaking capacity AC-3	8 x Ie AC-3 acc. to IEC 60947-4-1				
Short-circuit protection device for contactors without thermal overload relay - Motor protection excluded					
Circuit breaker		1250 A	1600 A	2000 A	2500 A
Rated short-time withstand current Icw at 40 °C ambient temperature, in free air from a cold state	1 s	9000 A	11000 A	13000 A	15000 A
	10 s	6400 A	9000 A	11000 A	12000 A
	30 s	3200 A	5000 A	6000 A	7000 A
	1 min	2100 A	3600 A	4200 A	4600 A
	15 min	1200 A	1900 A	2200 A	2600 A
Maximum breaking capacity cos $\phi = 0.45$	at 690 V	6400 A	8500 A	11000 A	
(cos $\phi = 0.35$ for Ie > 100 A)	at 1000 V	4650 A	5000 A	8500 A	
Maximum making capacity		14000 A	19000 A	21000 A	24000 A
Dynamical withstand of pole		14000 A	19000 A	21000 A	24000 A
Impedance per pole		0.28 m Ω	0.24 m Ω	0.18 m Ω	0.17 m Ω
Maximum electrical switching frequency	AC-1	300 cycles/h	150 cycles/h	120 cycles/h	
	AC-3	300 cycles/h	150 cycles/h	120 cycles/h	
Mechanical durability					
Number of operating cycles		5 millions cycles	2 millions cycles		
Max. switching frequency		1200 cycles/h	600 cycles/h		

Note: These characteristics are suitable for IOR..MT-AME contactor versions (except for mechanical durability = 0.2 millions of operating cycles).

IORR2500..MT ... IORR5100..MT and IORE2500..MT ... IORE5100..MT contactors

Technical data

Main pole - Utilization characteristics according to IEC

Contactor types	AC operated	IORR2500..MT	IORR3200..MT	IORR3800..MT	IORR4500..MT	IORR5100..MT
	DC operated	IORE2500..MT	IORE3200..MT	IORE3800..MT	IORE4500..MT	IORE5100..MT
Standards	IEC 60947-1 / 60947-4-1 and EN 60947-1 / 60947-4-1					
Rated operational voltage Ue max.	690 V					
Rated frequency (without derating)	25...60 Hz (for > 60...400 Hz please consult us)					
Number of poles	2...4					
Conventional free-air thermal current Ith						
acc. to IEC 60947-4-1, open contactors, $\theta \leq 40^\circ\text{C}$	2200 A	3000 A	3500 A	4000 A	4500 A	
With conductor cross-sectional area	2000 mm ²	3000 mm ²	3000 mm ²	4000 mm ²	4000 mm ²	
AC-1 Utilization category						
For air temperature close to contactor						
Ie / Rated operational current AC-1	$\theta \leq 40^\circ\text{C}$	2200 A	3000 A	3500 A	4000 A	4500 A
Ue max. $\leq 690\text{ V}$, 50/60 Hz	$\theta \leq 55^\circ\text{C}$	1930 A	2630 A	3070 A	3510 A	3950 A
	$\theta \leq 70^\circ\text{C}$	1620 A	2200 A	2570 A	2940 A	3300 A
With conductor cross-sectional area		2000 mm ²	3000 mm ²	3000 mm ²	4000 mm ²	4000 mm ²
Rated making capacity AC-1	1.5 x Ie AC-1 acc. to IEC 60947-4-1					
Rated breaking capacity AC-1	1.5 x Ie AC-1 acc. to IEC 60947-4-1					
AC-3 Utilization category						
For air temperature close to contactor $\theta \leq 55^\circ\text{C}$						
Ie / Max. rated operational current AC-3						
						
	690 V	Please consult us				
Short-circuit protection device for contactors						
without thermal overload relay - Motor protection excluded						
Circuit breaker	-	-	-	-	-	-
Rated short-time withstand current Icw						
at 40 °C ambient temperature,	1 s	20000 A	21000 A	24000 A	28000 A	30000 A
in free air from a cold state	10 s	15000 A	18000 A	19000 A	21000 A	24000 A
	30 s	8000 A	10000 A	11000 A	12000 A	13000 A
	1 min	6000 A	7000 A	7500 A	8000 A	9000 A
	15 min	3000 A	4000 A	4500 A	5000 A	5500 A
Maximum making capacity		24000 A	26000 A	29000 A	32000 A	32000 A
Dynamical withstand of pole		24000 A	26000 A	29000 A	32000 A	32000 A
Impedance per pole		0.12 m Ω	0.09 m Ω	0.085 m Ω	0.06 m Ω	0.055 m Ω
Maximum electrical switching frequency	AC-1	60 cycles/h		40 cycles/h		
Mechanical durability						
Number of operating cycles		2 millions cycles		1 million cycles		
Max. switching frequency		600 cycles/h		300 cycles/h		

Note: These characteristics are suitable for IOR..MT-AME contactor versions (except for mechanical durability = 0.2 millions of operating cycles).

Notes

Handwriting practice area consisting of multiple horizontal dotted lines for text entry.



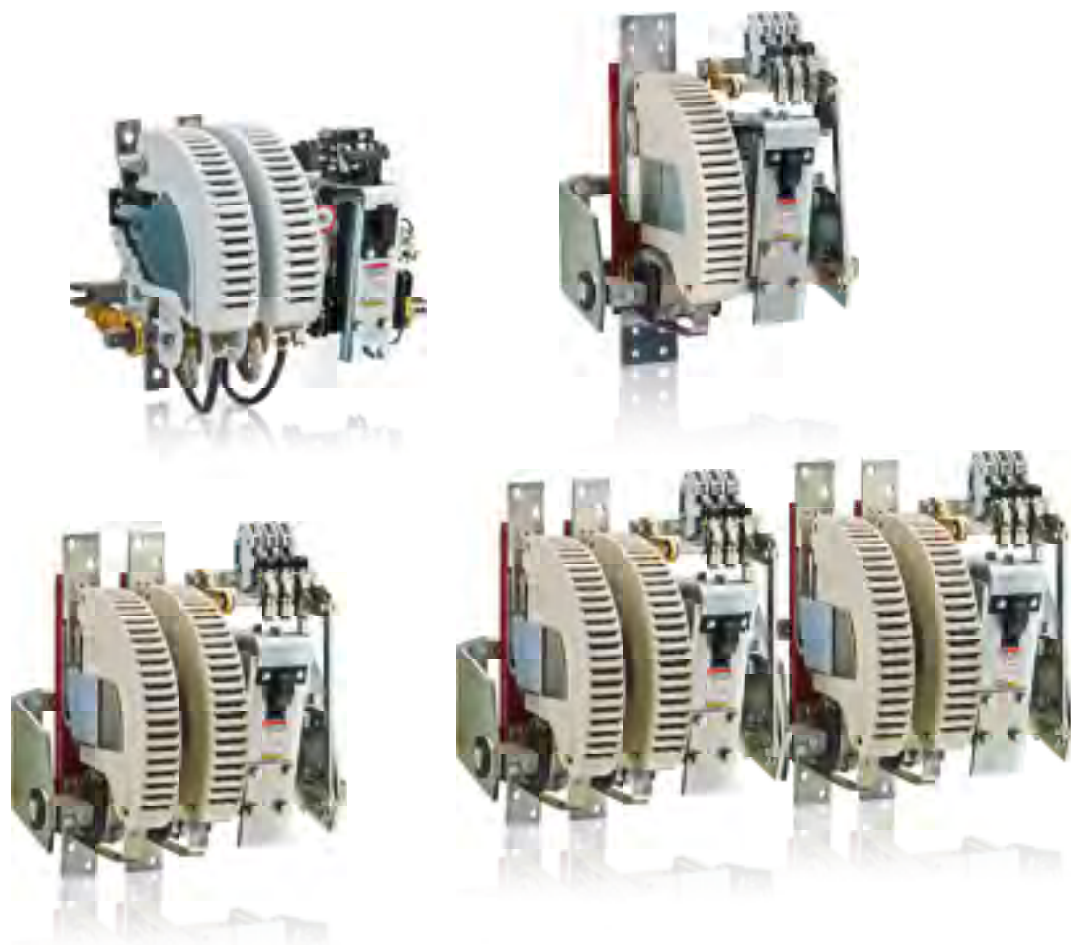

DC circuit switching

[Overview](#) 4/2

Ordering details

Power circuit up to 1500 V DC

IORR..CC	AC operated	4/4
IORE..CC	DC operated	4/5

Power circuit up to 600 V DC acc. to UL / CSA

IORR..CC-U	AC operated	4/6
IORE..CC-U	DC operated	4/7

Power circuit up to 1500 V DC, with latching

IORR..CC-AMA	AC operated	4/8
IORR..CC-AME	AC operated	4/8
IOR..CC-AMA	DC operated	4/9
IORE..CC-AME	DC operated	4/9

[Technical data](#) 4/10

[Type and order code for R contactors](#) 2/6



R contactors for DC circuit switching

Rated operational voltage

U_e up to **1500 V DC**



4

Contactor type	AC control circuit	~	IORR63..CC	IORR125..CC	IORR200..CC	IORR400..CC	IORR500..CC
	DC control circuit	≡	IORE63..CC	IORE125..CC	IORE200..CC	IORE400..CC	IORE500..CC
Number of poles in series	Categories	U _e max.					
1 pole	DC-1	500 V DC	I _e 85 A	170 A	275 A	400 A	550 A
	DC-3 / DC-5	500 V DC	I _e 68 A	125 A	205 A	350 A	500 A
2 poles	DC-1	1000 V DC	I _e 85 A	170 A	275 A	400 A*	550 A*
	DC-3 / DC-5	1000 V DC	I _e 68 A	125 A	205 A	350 A	500 A
3 poles	DC-1	1500 V DC	I _e 85 A*	170 A*	275 A*	400 A*	550 A*
	DC-3 / DC-5	1500 V DC	I _e 68 A*	125 A*	205 A*	350 A*	500 A*

* U_e max. = 1500 V DC, version with increased insulation for 1000 V DC < U_e ≤ 1500 V DC, please consult us.



Contactors

UL / CSA approved 

Rated operational voltage

U_e up to **600 V DC**

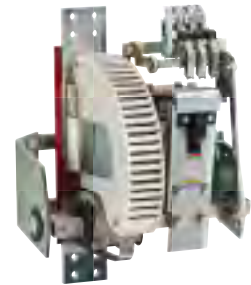
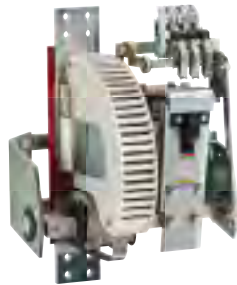

Contactor type	AC control circuit	~	IORR800-10-CC	IORR1000-10-CC	IORR1400-10-CC	IORR1700-10-CC	IORR2100-10-CC
	DC control circuit	≡	IORE800-10-CC	IORE1000-10-CC	IORE1400-10-CC	IORE1700-10-CC	IORE2100-10-CC
		U max.					
1 pole	General use	600 V DC	I _e 800 A	1000 A	1300 A	1700 A	2000 A

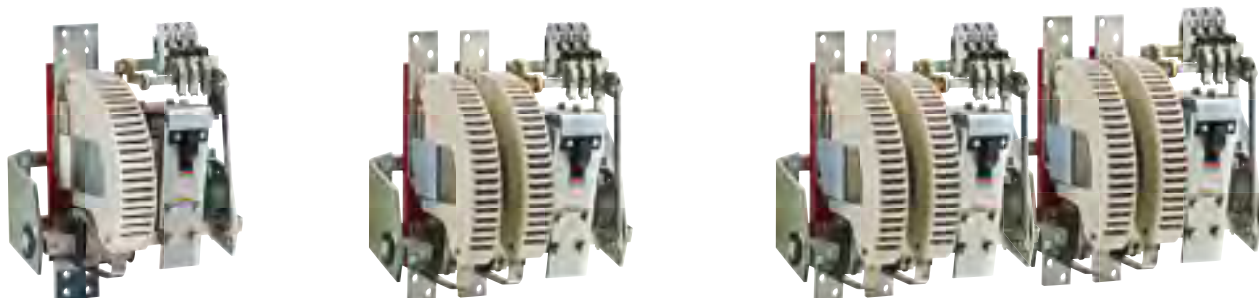

	IORR800..CC	IORR1000..CC	IORR1400..CC	IORR1700..CC	IORR2100..CC	IORR2500..CC	IORR3200..CC	IORR3800..CC	IORR4500..CC	IORR5100..CC
	IORE800..CC	IORE1000..CC	IORE1400..CC	IORE1700..CC	IORE2100..CC	IORE2500..CC	IORE3200..CC	IORE3800..CC	IORE4500..CC	IORE5100..CC

Ue max.

750 V DC	800 A	1000 A	1250 A	1600 A	2000 A	2300 A	3200 A	3800 A	4500 A	5000 A
600 V DC	720 A	1000 A	1250 A	1600 A	2000 A	On request	On request	On request	On request	On request
1500 V DC	800 A	1000 A	1250 A	1600 A	2000 A	2300 A	3200 A	3800 A	4500 A	5000 A
1000 V DC	720 A	1000 A	1250 A	1600 A	2000 A	On request	On request	On request	On request	On request
1500 V DC	800 A	1000 A	1250 A	1600 A	2000 A	2300 A	3200 A	3800 A	4500 A	5000 A
1500 V DC	720 A	1000 A	1250 A	1600 A	2000 A	On request	On request	On request	On request	On request



IORR..CC contactors

Power circuit up to 1500 V DC

AC operated

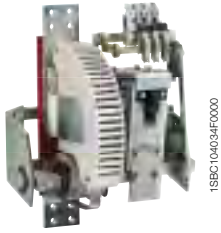

IORR800-10-CC

Description

IORR..CC contactors are used for controlling Rated DC power circuits up to 1500 V DC.

These contactors are designed with:

- variable number of poles according to the application
- control circuit: AC operated
- 1 N.O. and 1 N.C. auxiliary contacts available, as standard.

Blowout in DC circuit switching

If the breaking current is lower than 50 % of the contactor rating, permanent magnet must be added, see blowout code table.

Ordering details

IEC DC-1 Rated operational current		DC-3 / DC-5 Rated operational current		Number of poles	Rated control circuit voltage Uc (1) V 50/60 Hz	Auxiliary contacts fitted (2)	Type	Order code	Weight pkg (1 pce) kg
A	V DC	A	V DC						
85	500	68	500	1	220...230	1 1	IORR63-10-CC	FPL7116116R0006	3.2
	1000		1000	2		1 1	IORR63-20-CC	FPL7116216R0006	4.2
	1500		1500	3		1 1	IORR63-30-CC	On request	5.2
170	500	125	500	1	220...230	1 1	IORR125-10-CC	FPL7416115R0006	4.2
	1000		1000	2		1 1	IORR125-20-CC	FPL7416215R0006	6.2
	1500		1500	3		1 1	IORR125-30-CC	On request	8.2
275	500	205	500	1	220...230	1 1	IORR200-10-CC	FPL7616115R0006	6.6
	1000		1000	2		1 1	IORR200-20-CC	FPL7616215R0006	9.6
	1500		1500	3		1 1	IORR200-30-CC	On request	12.6
400	500	350	500	1	220...230	1 1	IORR400-10-CC	FPL9416115R0006	13.9
	1000		1000	2		1 1	IORR400-20-CC	FPL9416215R0006	19.7
	1500		1500	3		1 1	IORR400-30-CC	On request	25.5
550	500	500	500	1	220...230	1 1	IORR500-10-CC	FPL8316115R0006	13.9
	1000		1000	2		1 1	IORR500-20-CC	FPL8316215R0006	19.7
	1500		1500	3		1 1	IORR500-30-CC	On request	25.5
800	750	720	600	1	220...230	1 1	IORR800-10-CC	FPL8616115R0006	30
	1500		1000	2		1 1	IORR800-20-CC	FPL8616215R0006	40
	-		1500	3		1 1	IORR800-30-CC	FPL8616315R0006	51
1000	750	1000	600	1	220...230	1 1	IORR1000-10-CC	FPL8716115R0006	31
	1500		1000	2		1 1	IORR1000-20-CC	FPL8716215R0006	42
	-		1500	3		1 1	IORR1000-30-CC	FPL8716315R0006	50
1250	750	1250	600	1	220...230	1 1	IORR1400-10-CC	FPL6116115R0006	32
	1500		1000	2		1 1	IORR1400-20-CC	FPL6116215R0006	42
	-		1500	3		1 1	IORR1400-30-CC	FPL6116315R0006	52
1600	750	1600	600	1	220...230	1 1	IORR1700-10-CC	FPL6216185R0006	34
	1500		1000	2		1 1	IORR1700-20-CC	FPL6216215R0006	47
	-		1500	3		1 1	IORR1700-30-CC	FPL6216315R0006	61
2000	750	2000	600	1	220...230	1 1	IORR2100-10-CC	FPL6316185R0006	37
	1500		1000	2		1 1	IORR2100-20-CC	FPL6316215R0006	52
	-		1500	3		1 1	IORR2100-30-CC	FPL6316315R0006	68
2300	750	On request	On request	1	220...230	1 1	IORR2500-10-CC	FPL6716115R0006	45
	1500		On request	2		1 1	IORR2500-20-CC	FPL6716215R0006	71
	-		On request	3		1 1	IORR2500-30-CC	FPL6716315R0006	On request
3200	750	On request	On request	1	220...230	1 1	IORR3200-10-CC	FPL6516115R0006	52
	1500		On request	2		1 1	IORR3200-20-CC	FPL6516215R0006	83
	-		On request	3		1 1	IORR3200-30-CC	FPL6516315R0006	On request
3800	750	On request	On request	1	220...230	1 1	IORR3800-10-CC	FPL6616115R0006	58
	1500		On request	2		1 1	IORR3800-20-CC	FPL6616215R0006	95
	-		On request	3		1 1	IORR3800-30-CC	On request	On request
4500	750	On request	On request	1	220...230	1 1	IORR4500-10-CC	FPL6816115R0006	On request
	1500		On request	2		1 1	IORR4500-20-CC	FPL6816215R0006	On request
	-		On request	3		1 1	IORR4500-30-CC	On request	On request
5000	750	On request	On request	1	220...230	1 1	IORR5100-10-CC	FPL6916115R0006	On request
	1500		On request	2		1 1	IORR5100-20-CC	On request	On request
	-		On request	3		1 1	IORR5100-30-CC	On request	On request

(1) Other control voltages see voltage code table.

(2) Other auxiliary contact arrangements, see auxiliary contact code table.

(3) Power circuit above 1500 V DC, please consult us.

IORE..CC contactors

Power circuit up to 1500 V DC

DC operated

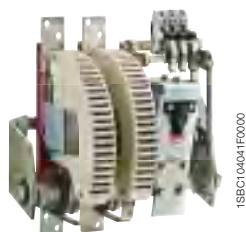

IORE1400-20-CC

1SBC10041F0000

Description

IORE..CC contactors are used for controlling DC power circuits up to 1500 V DC.

These contactors are designed with:

- variable number of poles according to the application
- control circuit: DC operated
- 1 N.O. and 1 N.C. auxiliary contacts available, as standard.

Blowout in DC circuit switching

If the breaking current is lower than 50 % of the contactor rating, permanent magnet must be added, see blowout code table.

Ordering details

IEC DC-1 Rated operational current		DC-3 / DC-5 Rated operational current		Number of poles	Rated con- trol circuit voltage Uc (1)	Auxiliary contacts fitted (2)	Type	Order code	Weight pkg (1 pce) kg
V DC	A	V DC	A						
85	500	68	500	1	220	1 1	IORE63-10-CC	FPL7110116R0006	3.2
	1000		1000	2		1 1	IORE63-20-CC	FPL7110216R0006	4.2
	1500		1500	3		1 1	IORE63-30-CC	On request	5.2
170	500	125	500	1	220	1 1	IORE125-10-CC	FPL7410115R0006	4.2
	1000		1000	2		1 1	IORE125-20-CC	FPL7410215R0006	6.2
	1500		1500	3		1 1	IORE125-30-CC	On request	8.2
275	500	205	500	1	220	1 1	IORE200-10-CC	FPL7610115R0006	6.6
	1000		1000	2		1 1	IORE200-20-CC	FPL7610215R0006	9.6
	1500		1500	3		1 1	IORE200-30-CC	On request	12.6
400	500	350	500	1	220	1 1	IORE400-10-CC	FPL9410115R0006	13.9
	1000		1000	2		1 1	IORE400-20-CC	FPL9410215R0006	19.7
	1500		1500	3		1 1	IORE400-30-CC	On request	25.5
550	500	500	500	1	220	1 1	IORE500-10-CC	FPL8310115R0006	13.9
	1000		1000	2		1 1	IORE500-20-CC	FPL8310215R0006	19.7
	1500		1500	3		1 1	IORE500-30-CC	On request	25.5
800	750	720	600	1	220	1 1	IORE800-10-CC	FPL8610115R0006	31
	1500		1000	2		1 1	IORE800-20-CC	FPL8610215R0006	40
	-		1500	3		1 1	IORE800-30-CC	FPL8610315R0006	51
1000	750	1000	600	1	220	1 1	IORE1000-10-CC	FPL8710115R0006	31
	1500		1000	2		1 1	IORE1000-20-CC	FPL8710215R0006	40
	-		1500	3		1 1	IORE1000-30-CC	FPL8710315R0006	50
1250	750	1250	600	1	220	1 1	IORE1400-10-CC	FPL6110115R0006	32
	1500		1000	2		1 1	IORE1400-20-CC	FPL6110215R0006	42
	-		1500	3		1 1	IORE1400-30-CC	FPL6110315R0006	52
1600	750	1600	600	1	220	1 1	IORE1700-10-CC	FPL6210185R0006	34
	1500		1000	2		1 1	IORE1700-20-CC	FPL6210215R0006	47
	-		1500	3		1 1	IORE1700-30-CC	FPL6210315R0006	61
2000	750	2000	600	1	220	1 1	IORE2100-10-CC	FPL6310185R0006	37
	1500		1000	2		1 1	IORE2100-20-CC	FPL6310215R0006	52
	-		1500	3		1 1	IORE2100-30-CC	FPL6310315R0006	68
2300	750	On request	On request	1	220	1 1	IORE2500-10-CC	FPL6710115R0006	45
	1500		On request	2		1 1	IORE2500-20-CC	FPL6710215R0006	71
	-		On request	3		1 1	IORE2500-30-CC	FPL6710315R0006	On request
3200	750	On request	On request	1	220	1 1	IORE3200-10-CC	FPL6510115R0006	52
	1500		On request	2		1 1	IORE3200-20-CC	FPL6510215R0006	83
	-		On request	3		1 1	IORE3200-30-CC	FPL6510315R0006	On request
3800	750	On request	On request	1	220	1 1	IORE3800-10-CC	FPL6610115R0006	58
	1500		On request	2		1 1	IORE3800-20-CC	FPL6610215R0006	95
	-		On request	3		1 1	IORE3800-30-CC	On request	On request
4500	750	On request	On request	1	220	1 1	IORE4500-10-CC	FPL6810115R0006	On request
	1500		On request	2		1 1	IORE4500-20-CC	FPL6810215R0006	On request
	-		On request	3		1 1	IORE4500-30-CC	On request	On request
5000	750	On request	On request	1	220	1 1	IORE5100-10-CC	FPL6910115R0006	On request
	1500		On request	2		1 1	IORE5100-20-CC	On request	On request
	-		On request	3		1 1	IORE5100-30-CC	On request	On request

(1) Other control voltages see voltage code table.

(2) Other auxiliary contact arrangements, see auxiliary contact code table.

(3) Power circuit above 1500 V DC, please consult us.

IORR..CC-U contactors

Power circuit up to 600 V DC acc. to UL / CSA

AC operated

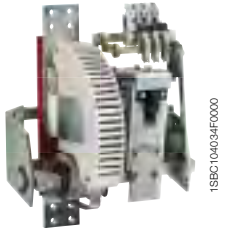

195C104034F0000

IORR800-10-CC-U

Description



IORR..CC-U contactors are used for controlling DC power circuits up to 600 V DC.

These contactors are designed with:

- 1 N.O. pole
- control circuit: AC operated
- 1 N.O. and 1 N.C. auxiliary contacts available, as standard.

For R800 ... R2100 contactors, if the breaking current is lower than 50 % of the contactor rating, permanent magnet must be added (non UL type).

Ordering details

UL / CSA General use rating 600 V DC	Number of poles	Rated con- trol circuit voltage Uc (1) V 50/60 Hz	Auxiliary contacts fitted (2)	Type	Order code	Weight pkg (1 pce) kg
A						
800	1	220...230	1 1	IORR800-10-CC-U	FPL8616195R0006	30
1000	1	220...230	1 1	IORR1000-10-CC-U	FPL8716195R0006	31
1300	1	220...230	1 1	IORR1400-10-CC-U	FPL6116195R0006	32
1700	1	220...230	1 1	IORR1700-10-CC-U	FPL6216195R0006	34
2000	1	220...230	1 1	IORR2100-10-CC-U	FPL6316195R0006	37

(1) Other control voltages see voltage code table.

(2) Other auxiliary contact arrangements, see auxiliary contact code table.



IORE..CC-U contactors

Power circuit up to 600 V DC acc. to UL / CSA

DC operated

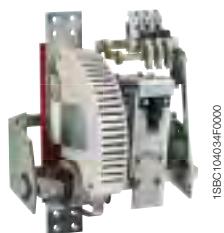

IORE800-10-CC-U

Description

IORE..CC-U contactors are used for controlling DC power circuits up to 600 V DC.

These contactors are designed with:

- 1 N.O. pole
- control circuit: DC operated
- 1 N.O. and 1 N.C. auxiliary contacts available, as standard.

For R800 ... R2100 contactors, if the breaking current is lower than 50 % of the contactor rating, permanent magnet must be added (non UL type).

Ordering details

UL / CSA General use rating 600 V DC	Number of poles	Rated con- trol circuit voltage Uc (1) V DC	Auxiliary contacts fitted (2)	Type	Order code	Weight pkg (1 pce) kg
A						
800	1	220	1 1	IORE800-10-CC-U	FPL8610195R0006	30
1000	1	220	1 1	IORE1000-10-CC-U	FPL8710195R0006	31
1300	1	220	1 1	IORE1400-10-CC-U	FPL6110195R0006	32
1700	1	220	1 1	IORE1700-10-CC-U	FPL6210195R0006	34
2000	1	220	1 1	IORE2100-10-CC-U	FPL6310195R0006	37

(1) Other control voltages see voltage code table.

(2) Other auxiliary contact arrangements, see auxiliary contact code table.



IORR..CC-AMA and IORR..CC-AME contactors

Power circuit up to 1500 V DC, with latching

AC operated

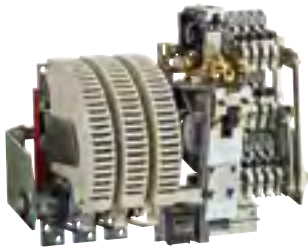

IORR800-30-CC-AME

Description

IORR..CC-AMA and IORR..CC-AME contactors are used for controlling DC power circuits up to 1500 V DC.

These contactors are designed with:

- magnetical latching, AMA types
- mechanical latching, AME types
- variable number of poles according to the application
- control circuit: AC operated
- 1 N.O. auxiliary contact available for AMA version, as standard
- 1 N.O. and 1 N.C. auxiliary contacts available for AME version.

Ordering details

IEC		DC-3 / DC-5		Number of poles	Rated control circuit voltage U _c (1)	Auxiliary contacts fitted (2)	Type	Order code	Weight
DC-1	Rated operational current (3)	Rated operational current (3)	Rated operational voltage (3)						
A	V DC	A	V DC		V 50/60 Hz				pkg (1 pce)
Magnetical latching									
85	500	68	500	1	220...230	1 0	IORR63-10-CC-AMA	FPL7116136R0006	2.9
	1000		1000	2		1 0	IORR63-20-CC-AMA	FPL7116236R0006	3.9
	1500		1500	3		1 0	IORR63-30-CC-AMA	On request	4.9
170	500	125	500	1	220...230	1 0	IORR125-10-CC-AMA	FPL7416135R0006	3.9
	1000		1000	2		1 0	IORR125-20-CC-AMA	FPL7416235R0006	5.9
	1500		1500	3		1 0	IORR125-30-CC-AMA	On request	7.9
275	500	205	500	1	220...230	1 0	IORR200-10-CC-AMA	FPL7616135R0006	6.2
	1000		1000	2		1 0	IORR200-20-CC-AMA	FPL7616235R0006	9.2
	1500		1500	3		1 0	IORR200-30-CC-AMA	On request	12.2
Mechanical latching									
400	500	350	500	1	220...230	1 1	IORR400-10-CC-AME	FPL9416125R0116	18.4
	1000		1000	2		1 1	IORR400-20-CC-AME	FPL9416225R0116	24.2
	1500		1500	3		1 1	IORR400-30-CC-AME	On request	30
550	500	500	500	1	220...230	1 1	IORR500-10-CC-AME	FPL8316125R0116	18.4
	1000		1000	2		1 1	IORR500-20-CC-AME	FPL8316225R0116	24.2
	1500		1500	3		1 1	IORR500-30-CC-AME	On request	30
800	750	720	600	1	220...230	1 1	IORR800-10-CC-AME	FPL8616125R0116	40
	1500		1000	2		1 1	IORR800-20-CC-AME	FPL8616225R0116	50
	-		1500	3		1 1	IORR800-30-CC-AME	FPL8616325R0116	61
1000	750	720	600	1	220...230	1 1	IORR1000-10-CC-AME	FPL8716125R0116	40
	1500		1000	2		1 1	IORR1000-20-CC-AME	FPL8716225R0116	50
	-		1500	3		1 1	IORR1000-30-CC-AME	FPL8716325R0116	61
1250	750	720	600	1	220...230	1 1	IORR1400-10-CC-AME	FPL6116125R0116	42
	1500		1000	2		1 1	IORR1400-20-CC-AME	FPL6116225R0116	52
	-		1500	3		1 1	IORR1400-30-CC-AME	FPL6116325R0116	62
1600	750	720	600	1	220...230	1 1	IORR1700-10-CC-AME	FPL6216125R0116	43
	1500		1000	2		1 1	IORR1700-20-CC-AME	FPL6216225R0116	57
	-		1500	3		1 1	IORR1700-30-CC-AME	FPL6216325R0116	71
2000	750	720	600	1	220...230	1 1	IORR2100-10-CC-AME	FPL6316125R0116	46
	1500		1000	2		1 1	IORR2100-20-CC-AME	FPL6316225R0116	62
	-		1500	3		1 1	IORR2100-30-CC-AME	FPL6316325R0116	78
2300	750	On request	On request	1	220...230	1 1	IORR2500-10-CC-AME	FPL6716125R0116	On request
	1500		On request	2		1 1	IORR2500-20-CC-AME	FPL6716225R0116	On request
	-		On request	3		1 1	IORR2500-30-CC-AME	FPL6716325R0116	On request
3200	750	On request	On request	1	220...230	1 1	IORR3200-10-CC-AME	FPL6516125R0116	On request
	1500		On request	2		1 1	IORR3200-20-CC-AME	FPL6516225R0116	On request
	-		On request	3		1 1	IORR3200-30-CC-AME	FPL6516325R0116	On request
3800	750	On request	On request	1	220...230	1 1	IORR3800-10-CC-AME	FPL6616125R0116	On request
	1500		On request	2		1 1	IORR3800-20-CC-AME	FPL6616225R0116	On request
4500	750	On request	On request	1	220...230	1 1	IORR4500-10-CC-AME	FPL6816125R0116	On request
	1500		On request	2		1 1	IORR4500-20-CC-AME	FPL6816225R0116	On request
5000	750	On request	On request	1	220...230	1 1	IORR5100-10-CC-AME	FPL6916125R0116	On request

(1) Other control voltages see voltage code table.

(2) Other auxiliary contact arrangements, see auxiliary contact code table.

(3) Power circuit above 1500 V DC, please consult us.

IOR..CC-AMA and IORE..CC-AME contactors

Power circuit up to 1500 V DC, with latching

DC operated

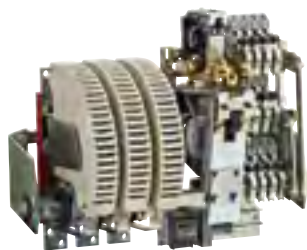

IORE800-30-CC-AME

1SBC10444F0000

Description

IOR..CC-AMA and IORE..CC-AME contactors are used for controlling DC power circuits up to 1500 V DC.

These contactors are designed with:

- magnetical latching, AMA types
- mechanical latching, AME types
- variable number of poles according to the application
- control circuit: DC operated
- 1 N.O. auxiliary contact available for AMA version, as standard
- 1 N.O. and 1 N.C. auxiliary contacts available for AME version.

Ordering details

IEC		DC-3 / DC-5		Number of poles	Rated control circuit voltage U _c (1)	Auxiliary contacts fitted (2)	Type	Order code	Weight
DC-1	DC-3 / DC-5	Rated operational Current (3)	Rated operational Voltage (3)						
A	V DC	A	V DC		V DC				pkg (1 pce)

Magnetical latching

85	500	68	500	1	220	1 0	IOR63-10-CC-AMA	FPL7112136R0006	2.9
	1000		1000	2		1 0	IOR63-20-CC-AMA	FPL7112236R0006	3.9
	1500		1500	3		1 0	IOR63-30-CC-AMA	On request	4.9
170	500	125	500	1	220	1 0	IOR125-10-CC-AMA	FPL7412135R0006	3.9
	1000		1000	2		1 0	IOR125-20-CC-AMA	FPL7412235R0006	5.9
	1500		1500	3		1 0	IOR125-30-CC-AMA	On request	7.9
275	500	205	500	1	220	1 0	IOR200-10-CC-AMA	FPL7612135R0006	6.2
	1000		1000	2		1 0	IOR200-20-CC-AMA	FPL7612235R0006	9.2
	1500		1500	3		1 0	IOR200-30-CC-AMA	On request	12.2

Mechanical latching

400	500	350	500	1	220	1 1	IORE400-10-CC-AME	FPL9410125R0116	18.4
	1000		1000	2		1 1	IORE400-20-CC-AME	FPL9410225R0116	24.2
	1500		1500	3		1 1	IORE400-30-CC-AME	On request	30
550	500	500	500	1	220	1 1	IORE500-10-CC-AME	FPL8310125R0116	18.4
	1000		1000	2		1 1	IORE500-20-CC-AME	FPL8310225R0116	24.2
	1500		1500	3		1 1	IORE500-30-CC-AME	On request	30
800	750	720	600	1	220	1 1	IORE800-10-CC-AME	FPL8610125R0116	40
	1500		1000	2		1 1	IORE800-20-CC-AME	FPL8610225R0116	50
	-		1500	3		1 1	IORE800-30-CC-AME	FPL8610325R0116	61
1000	750	720	600	1	220	1 1	IORE1000-10-CC-AME	FPL8710125R0116	40
	1500		1000	2		1 1	IORE1000-20-CC-AME	FPL8710225R0116	50
	-		1500	3		1 1	IORE1000-30-CC-AME	FPL8710325R0116	61
1250	750	720	600	1	220	1 1	IORE1400-10-CC-AME	FPL6110125R0116	42
	1500		1000	2		1 1	IORE1400-20-CC-AME	FPL6110225R0116	52
	-		1500	3		1 1	IORE1400-30-CC-AME	FPL6110325R0116	62
1600	750	720	600	1	220	1 1	IORE1700-10-CC-AME	FPL6210125R0116	43
	1500		1000	2		1 1	IORE1700-20-CC-AME	FPL6210225R0116	57
	-		1500	3		1 1	IORE1700-30-CC-AME	FPL6210325R0116	71
2000	750	720	600	1	220	1 1	IORE2100-10-CC-AME	FPL6310125R0116	46
	1500		1000	2		1 1	IORE2100-20-CC-AME	FPL6310225R0116	62
	-		1500	3		1 1	IORE2100-30-CC-AME	FPL6310325R0116	78
2300	750	On request	On request	1	220	1 1	IORE2500-10-CC-AME	FPL6710125R0116	On request
	1500	On request	On request	2		1 1	IORE2500-20-CC-AME	FPL6710225R0116	On request
	-	On request	On request	3		1 1	IORE2500-30-CC-AME	FPL6710325R0116	On request
3200	750	On request	On request	1	220	1 1	IORE3200-10-CC-AME	FPL6510125R0116	On request
	1500	On request	On request	2		1 1	IORE3200-20-CC-AME	FPL6510225R0116	On request
	-	On request	On request	3		1 1	IORE3200-30-CC-AME	FPL6510325R0116	On request
3800	750	On request	On request	1	220	1 1	IORE3800-10-CC-AME	FPL6610125R0116	On request
	1500	On request	On request	2		1 1	IORE3800-20-CC-AME	FPL6610225R0116	On request
4500	750	On request	On request	1	220	1 1	IORE4500-10-CC-AME	FPL6810125R0116	On request
	1500	On request	On request	2		1 1	IORE4500-20-CC-AME	FPL6810225R0116	On request
5000	750	On request	On request	1	220	1 1	IORE5100-10-CC-AME	FPL6910125R0116	On request

(1) Other control voltages see voltage code table.

(2) Other auxiliary contact arrangements, see auxiliary contact code table.









(3) Power circuit above 1500 V DC, please consult us.



IORR63..CC ... IORR500..CC and IORE63..CC ... IORE500..CC contactors

Technical data

Main pole - Utilization characteristics according to IEC

Contactor types	AC operated	IORR63..CC	IORR125..CC	IORR200..CC	IORR400..CC	IORR500..CC
	DC operated	IORE63..CC	IORE125..CC	IORE200..CC	IORE400..CC	IORE500..CC
Standards	IEC 60947-1 / 60947-4-1 and EN 60947-1 / 60947-4-1					
Rated operational voltage Ue max.	1000 V DC (1500 V DC with increased insulation (1))					
Number of poles	1...4					
Conventional free-air thermal current Ith acc. to IEC 60947-4-1, open contactors, $\theta \leq 40^\circ\text{C}$ With conductor cross-sectional area		85 A 25 mm ²	170 A 70 mm ²	275 A 150 mm ²	400 A 240 mm ²	550 A 400 mm ²
DC-1 Utilization category, L/R \leq 1 ms Ie / Rated operational current DC-1						
 1 pole						
$\leq 500\text{ V}$	85 A	170 A	275 A	400 A	550 A	
 2 poles in series						
$\leq 1000\text{ V}$	85 A	170 A	275 A	400 A	550 A	
$\leq 1500\text{ V (1)}$	-	-	-	400 A	550 A	
 3 poles in series						
$\leq 1500\text{ V (1)}$	85 A	170 A	275 A	400 A	550 A	
DC-3 Utilization category, L/R \leq 2 ms Ie / Rated operational current DC-3						
 1 pole						
$\leq 500\text{ V}$	68 A	125 A	205 A	350 A	500 A	
 2 poles in series						
$\leq 1000\text{ V}$	68 A	125 A	205 A	350 A	500 A	
 3 poles in series						
$\leq 1500\text{ V (1)}$	68 A	125 A	205 A	350 A	500 A	
DC-5 Utilization category, L/R \leq 7.5 ms Ie / Rated operational current DC-5						
 1 pole						
$\leq 500\text{ V}$	68 A	125 A	205 A	350 A	500 A	
 2 poles in series						
$\leq 1000\text{ V}$	68 A	125 A	205 A	350 A	500 A	
 3 poles in series						
$\leq 1500\text{ V (1)}$	68 A	125 A	205 A	350 A	500 A	
Rated short-time withstand current Icw at 40 °C ambient temperature, in free air from a cold state	1 s	1150 A	2250 A	3800 A	6000 A	8400 A
	10 s	680 A	1280 A	2080 A	3200 A	4400 A
	30 s	310 A	680 A	1040 A	1600 A	2200 A
	1 min	230 A	450 A	730 A	1200 A	1680 A
	15 min	120 A	250 A	390 A	600 A	840 A
Rated breaking capacity (L/R \leq 15 ms)	1 pole 500 V	272 A	500 A	820 A	1400 A	2000 A
	2 poles 1000 V	272 A	500 A	820 A	1400 A	2000 A
	3 poles 1500 V	272 A	500 A	820 A	1400 A	2000 A
Maximum making capacity		1300 A	2400 A	4000 A	7000 A	9000 A
Dynamical withstand of pole		1400 A	2500 A	4500 A	8000 A	10000 A
Impedance per pole		1.8 m Ω	1.20 m Ω	0.60 m Ω	0.40 m Ω	0.35 m Ω
Maximum electrical switching frequency		120 cycles/h				
Mechanical durability						
Number of operating cycles		5 millions cycles				
Maximum switching frequency		1200 cycles/h				

(1) Version with increased insulation for 1000 V < Ue < 1500 V, please consult us.

Notes: - The arc switching on DC is more difficult than on AC

- For information, typical time constant values are quoted hereafter: non inductive loads such as resistance furnaces: L/R < 1 ms; inductive loads such as shunt motor:

L/R < 2 ms; series motor: L/R < 7.5 ms

- The addition of a resistor in parallel with an inductive winding helps in the elimination of the arcs

- All the poles required for breaking must be connected, in series, between the load and the source polarity not linked to the earth









- Connection of the poles in series by the user, according to the above diagrams. The connection of the poles in series helps in the elimination of the arcs

- These characteristics are suitable for IOR..CC-AMA and IOR..CC-AME contactor latching versions (except for mechanical durability = 0.2 millions of operating cycles).

IORR800..CC ... IORR2100..CC and IORE800..CC ... IORE2100..CC contactors

Technical data

Main pole - Utilization characteristics according to IEC

Contactor types	AC operated	IORR800..CC	IORR1000..CC	IORR1400..CC	IORR1700..CC	IORR2100..CC
	DC operated	IORE800..CC	IORE1000..CC	IORE1400..CC	IORE1700..CC	IORE2100..CC
Standards	IEC 60947-1 / 60947-4-1 and EN 60947-1 / 60947-4-1					
Rated operational voltage Ue max.	1500 V DC					
Number of poles	1...4					
Conventional free-air thermal current Ith acc. to IEC 60947-4-1, open contactors, $\theta \leq 40$ °C With conductor cross-sectional area		800 A 500 mm ²	1000 A 600 mm ²	1300 A 1000 mm ²	1700 A 1500 mm ²	2000 A 1500 mm ²
DC-1 Utilization category, L/R \leq 1 ms Ie / Rated operational current DC-1						
 1 pole ≤ 750 V		800 A	1000 A	1250 A	1600 A	2000 A
 2 poles in series ≤ 1000 V		800 A	1000 A	1250 A	1600 A	2000 A
≤ 1500 V		800 A	1000 A	1250 A	1600 A	2000 A
DC-3 Utilization category, L/R \leq 2 ms Ie / Rated operational current DC-3						
 1 pole ≤ 600 V		720 A	1000 A	1250 A	1600 A	2000 A
 2 poles in series ≤ 1000 V		720 A	1000 A	1250 A	1600 A	2000 A
 3 poles in series ≤ 1500 V		720 A	1000 A	1250 A	1600 A	2000 A
DC-5 Utilization category, L/R \leq 7.5 ms Ie / Rated operational current DC-5						
 1 pole ≤ 600 V		720 A	1000 A	1250 A	1600 A	2000 A
 2 poles in series ≤ 1000 V		720 A	1000 A	1250 A	1600 A	2000 A
 3 poles in series ≤ 1500 V		720 A	1000 A	1250 A	1600 A	2000 A
Rated short-time withstand current Icw at 40 °C ambient temperature, in free air from a cold state						
1 s		9000 A	9000 A	11000 A	13000 A	15000 A
10 s		6400 A	6400 A	9000 A	11000 A	12000 A
30 s		3200 A	3200 A	5000 A	6000 A	7000 A
1 min		2100 A	2100 A	3600 A	4200 A	4600 A
15 min		1200 A	1200 A	1900 A	2200 A	2600 A
Rated breaking capacity (L/R \leq 15 ms)						
1 pole 600 V		2880 A	4000 A	5000 A	6400 A	8000 A
2 poles 1000 V		2880 A	4000 A	5000 A	6400 A	8000 A
3 poles 1500 V		2880 A	4000 A	5000 A	6400 A	8000 A
Maximum making capacity		14000 A	14000 A	19000 A	21000 A	24000 A
Dynamical withstand of pole		14000 A	14000 A	19000 A	21000 A	24000 A
Impedance per pole		0.28 m Ω	0.24 m Ω	0.18 m Ω	0.12 m Ω	0.10 m Ω
Maximum electrical switching frequency		120 cycles/h		60 cycles/h		
Mechanical durability		5 millions cycles		2 millions cycles		
Number of operating cycles		5 millions cycles		2 millions cycles		
Maximum switching frequency		1200 cycles/h		600 cycles/h		



Notes: - The arc switching on DC is more difficult than on AC

- For information, typical time constant values are quoted hereafter: non inductive loads such as resistance furnaces: L/R < 1 ms; inductive loads such as shunt motor: L/R < 2 ms; series motor: L/R < 7.5 ms
- The addition of a resistor in parallel with an inductive winding helps in the elimination of the arcs
- All the poles required for breaking must be connected, in series, between the load and the source polarity not linked to the earth
- Connection of the poles in series by the user, according to the above diagrams. The connection of the poles in series helps in the elimination of the arcs
- These characteristics are suitable for IOR..CC-AME contactor latching versions (except for mechanical durability = 0.2 millions of operating cycles).

IORR2500..CC ... IORR5100..CC and IORE2500..CC ... IORE5100..CC contactors

Technical data

Main pole - Utilization characteristics according to IEC

Contactor types	AC operated	IORR2500..CC	IORR3200..CC	IORR3800..CC	IORR4500..CC	IORR5100..CC
	DC operated	IORE2500..CC	IORE3200..CC	IORE3800..CC	IORE4500..CC	IORE5100..CC
Standards	IEC 60947-1 / 60947-4-1 and EN 60947-1 / 60947-4-1					
Rated operational voltage U_e max.	1500 V DC					
Number of poles	1...4					
Conventional free-air thermal current I_{th} acc. to IEC 60947-4-1, open contactors, $\theta \leq 40$ °C						
With conductor cross-sectional area	2300 A	3200 A	3800 A	4500 A	5000 A	
	2000 mm ²	3000 mm ²	3000 mm ²	4000 mm ²	4000 mm ²	
DC-1 Utilization category, L/R \leq 1 ms I_e / Rated operational current DC-1						
 1 pole						
≤ 750 V	2300 A	3200 A	3800 A	4500 A	5000 A	
 2 poles in series						
≤ 1000 V	2300 A	3200 A	3800 A	4500 A	5000 A	
≤ 1500 V	2300 A	3200 A	3800 A	4500 A	5000 A	
DC-3 Utilization category, L/R \leq 2 ms I_e / Rated operational current DC-3 For voltage up to 1500 V	Please consult us					
DC-5 Utilization category, L/R \leq 7.5 ms I_e / Rated operational current DC-5 For voltage up to 1500 V	Please consult us					
Rated short-time withstand current I_{cw} at 40 °C ambient temperature, in free air from a cold state						
1 s	20000 A	21000 A	24000 A	28000 A	30000 A	
10 s	15000 A	18000 A	19000 A	21000 A	24000 A	
30 s	8000 A	10000 A	11000 A	12000 A	13000 A	
1 min	6000 A	7000 A	7500 A	8000 A	9000 A	
15 min	3000 A	4000 A	4500 A	5000 A	5500 A	
Maximum making capacity	24000 A	26000 A	29000 A	32000 A	32000 A	
Dynamical withstand of pole	24000 A	26000 A	29000 A	32000 A	32000 A	
Impedance per pole	0.09 m Ω	0.06 m Ω	0.05 m Ω	0.04 m Ω	0.03 m Ω	
Maximum electrical switching frequency	60 cycles/h		40 cycles/h			
Mechanical durability						
Number of operating cycles	2 millions cycles		1 million cycles			
Maximum switching frequency	600 cycles/h		300 cycles/h			

Notes: - The arc switching on DC is more difficult than on AC

- For information, typical time constant values are quoted hereafter: non inductive loads such as resistance furnaces: L/R < 1 ms; inductive loads such as shunt motor: L/R < 2 ms; series motor: L/R < 7.5 ms
- The addition of a resistor in parallel with an inductive winding helps in the elimination of the arcs
- All the poles required for breaking must be connected, in series, between the load and the source polarity not linked to the earth
- Connection of the poles in series by the user, according to the above diagrams. The connection of the poles in series helps in the elimination of the arcs
- These characteristics are suitable for IOR..CC-AME contactor latching versions (except for mechanical durability = 0.2 millions of operating cycles).

Notes

Area with horizontal dotted lines for writing notes.



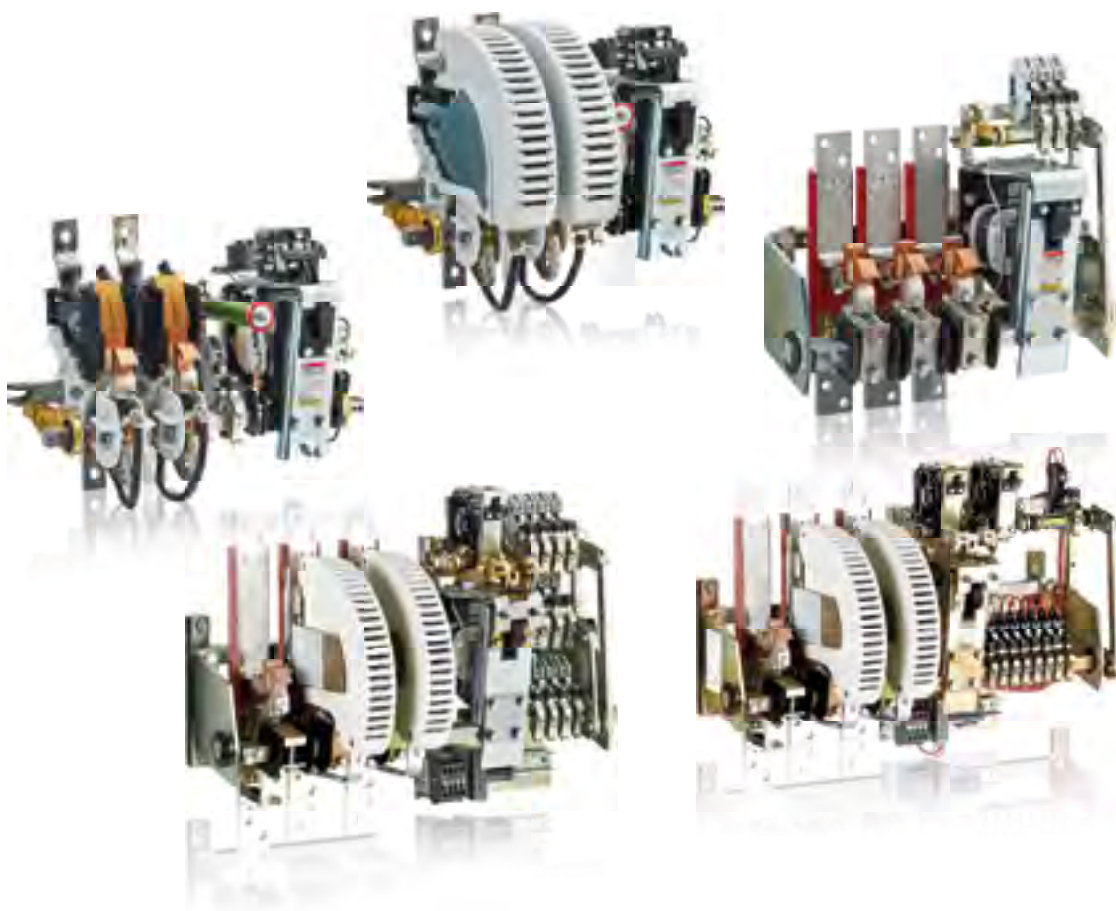

N.O. / N.C. main poles combination

Presentation	5/2
Power circuit up to 690 V AC	
NORR, NORR..MT AC operated	5/3
NORE, NORE..MT DC operated	5/3
Power circuit up to 1500 V DC	
NORR, NORR..CC AC operated	5/4
NORE, NORE..CC DC operated	5/4
Technical data	5/5

Power circuit coupling

Presentation	5/7
Power circuit up to 1000 V AC or 1500 V DC	
LORR AC operated	5/8
Power circuit up to 1000 V AC or 1000 V DC	
LORE DC operated	5/9
Technical data	5/10

Slip-ring motor control FOR contactors

5/12

Rotor voltages up to 1500 V AC

FORR1000 ... FORR3800 AC operated	5/14
FORE1000 ... FORE3800 DC operated	5/14

Rotor voltages up to 2500 V AC

FORR1000S ... FORR2100S AC operated	5/15
FORE1000S ... FORE2100S DC operated	5/15

Rotor voltages up to 3500 V AC

FORR1000NSP ... FORR2100NSP AC operated	5/16
FORE1000NSP ... FORE2100NSP DC operated	5/16

Rotor voltages up to 4200 V AC

FORR1000SPE ... FORR2100SPE AC operated	5/17
FORE1000SPE ... FORE2100SPE DC operated	5/17

Closed transition star-delta starting of three-phase asynchronous motors

5/18

Autotransformer starters

5/19

Alternator field discharge

5/21

Panorama	5/22
AM-CC-NOR technical data	5/24
AM-CC-JORE and AMF-CC-JORE technical data	5/30

Type and order code for R contactors

2/6



N.O. / N.C. main poles combination NOR contactors



5

Description

NOR contactors are built with a combination of N.O. and N.C. poles:

- AC switching: NOR..MT up to 690 V AC
- DC switching: NOR..CC up to 1500 V DC in standard.

For low current breaking, permanent magnet must be added.

1 N.O and 1 N.C. auxiliary contacts are fitted as standard. For additional auxiliary contacts refer to "Auxiliary contact fitting details".

Example of use :

Change-over contactor with 2 N.C. poles + 2 N.O. poles.

Block diagrams

These contactors are suitable for controlling 2 separate circuits, i.e. 2 loads with 2 separate supplies, or 1 circuit including 2 separate loads with a single supply (diagrams on left column).

When the contactor operates there is no mechanical overlapping between the N.O. poles and the N.C. poles: BREAK before MAKE operation.

These contactors are not suitable for a reversing starter or star-delta starter, or for controlling a single load from 2 separate supplies.

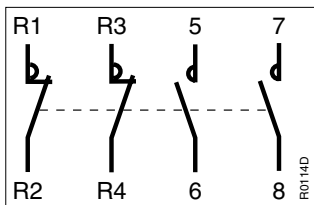

2 N.C. poles + 2 N.O. poles

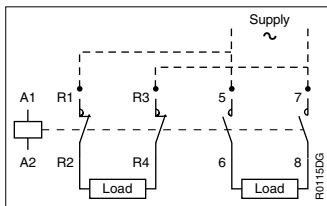

Single supply and 2 separate loads

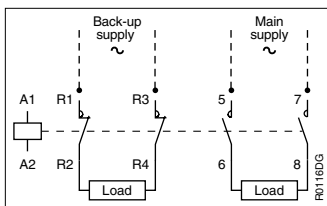

2 separate supplies and 2 separate loads

Operation

The N.O. and N.C. poles are set-up without any mechanical overlap:

- as the electro-magnet closes, the N.C. pole(s) BREAK before the N.O. pole(s) MAKE
- as the electro-magnet opens, the N.O. pole(s) BREAK before the N.C. pole(s) MAKE.

The breaking and making capacities of the N.C. poles are identical to those of the N.O. poles.

Other variants

Please consult us for :

- NOR..AMA and NOR..AME with latching
- JOR types: version with overlapping between N.O. and N.C. main poles.

NORR, NORE, NORR..MT and NORE..MT contactors

Power circuit up to 690 V AC

AC or DC operated



NORR125-02-MT

19BC1040/2F0000

Description

NORR..MT and NORE..MT contactors with N.O. and N.C. main poles are used for controlling AC power circuits up to 690 V AC.

NORR400 ... NORR800 and NORE400 ... NORE800 contactors with N.O. and N.C. main poles are used for controlling AC power circuits up to 500 V AC.

These contactors are designed with:

- variable number of poles according to the application
- control circuit: AC or DC operated
- 1 N.O. and 1 N.C. auxiliary contacts available, as standard.

AC operated

IEC Rated operational current $\theta \leq 40^\circ\text{C}$ AC-1 A	Rated operational voltage (3) V AC	Number of poles (4)	Rated con- trol circuit voltage Uc (1) V 50/60 Hz	Auxiliary contacts fitted (2)	Type	Order code	Weight pkg (1 pce) kg
63	690	0 2	220...230	1 1	NORR63-02-MT	FPL7155216R0006	4.2
		2 1		1 1	NORR63-21-MT	FPL7155516R0006	3.9
		3 1		1 1	NORR63-31-MT	FPL7155716R0006	4.9
125	690	0 2	220...230	1 1	NORR125-02-MT	FPL7455215R0006	6.2
		2 1		1 1	NORR125-21-MT	FPL7455515R0006	8.2
		3 1		1 1	NORR125-31-MT	FPL7455715R0006	9
200	690	0 2	220...230	1 1	NORR200-02-MT	FPL7655215R0006	9.6
		2 1		1 1	NORR200-21-MT	FPL7655515R0006	10
		3 1		1 1	NORR200-31-MT	FPL7655715R0006	12.2
315	500	0 2	220...230	1 1	NORR400-02	FPL9445215R0006	12
		2 1		1 1	NORR400-21	FPL9445515R0006	15
		3 1		1 1	NORR400-31	FPL9445715R0006	18
800	500	0 2	220...230	1 1	NORR800-02	FPL8645215R0006	38
		2 1		1 1	NORR800-21	FPL8645515R0006	48
		3 1		1 1	NORR800-31	FPL8645715R0006	58
	690	0 2	220...230	1 1	NORR800-02-MT	FPL8655215R0006	40
		2 1		1 1	NORR800-21-MT	FPL8655515R0006	51
		3 1		1 1	NORR800-31-MT	FPL8655715R0006	62

DC operated

IEC Rated operational current $\theta \leq 40^\circ\text{C}$ AC-1 A	Rated operational voltage (3) V AC	Number of poles (4)	Rated con- trol circuit voltage Uc (1) V DC	Auxiliary contacts fitted (2)	Type	Order code	Weight pkg (1 pce) kg
63	690	0 2	220	1 1	NORE63-02-MT	FPL7159216R0006	4.2
		2 1		1 1	NORE63-21-MT	FPL7159516R0006	3.9
		3 1		1 1	NORE63-31-MT	FPL7159716R0006	4.9
125	690	0 2	220	1 1	NORE125-02-MT	FPL7459215R0006	6.2
		2 1		1 1	NORE125-21-MT	FPL7459515R0006	8.2
		3 1		1 1	NORE125-31-MT	FPL7459715R0006	9
200	690	0 2	220	1 1	NORE200-02-MT	FPL7659215R0006	9.6
		2 1		1 1	NORE200-21-MT	FPL7659515R0006	10
		3 1		1 1	NORE200-31-MT	FPL7659715R0006	12.2
315	500	0 2	220	1 1	NORE400-02	FPL9449215R0006	12
		2 1		1 1	NORE400-21	FPL9449515R0006	15
		3 1		1 1	NORE400-31	FPL9449715R0006	18
800	500	0 2	220	1 1	NORE800-02	FPL8649215R0006	38
		2 1		1 1	NORE800-21	FPL8649515R0006	48
		3 1		1 1	NORE800-31	FPL8649715R0006	58
	690	0 2	220	1 1	NORE800-02-MT	FPL8659215R0006	40
		2 1		1 1	NORE800-21-MT	FPL8659515R0006	51
		3 1		1 1	NORE800-31-MT	FPL8659715R0006	62

(1) Other control voltages see voltage code table.

(2) Other auxiliary contact arrangements, see auxiliary contact code table.

(3) Power circuit above 690 V AC, please consult us.

(4) Other main pole combinations, please consult us.

NORR, NORE, NORR..CC and NORE..CC contactors

Power circuit up to 1500 V DC

AC or DC operated



1SBC1040/42F0000

NORR125-02-CC

Description

NORR..CC and NORE..CC contactors with N.O. and N.C. main poles are used for controlling DC power circuits up to 1500 V DC. NORR and NORE400 up to 440 V DC.

These contactors are designed with:

- variable number of poles according to the application
- control circuit: AC or DC operated
- 1 N.O. and 1 N.C. auxiliary contacts available, as standard.

AC operated

IEC		Rated operational current		voltage (3)		Number of poles (4)	Rated control circuit voltage U _c (1)	Auxiliary contacts fitted (2)	Type	Order code	Weight
DC-1	DC-3 DC-5	V DC	V DC	V DC	V DC						
A	A						V 50/60 Hz				kg
63	63	-	500	0	1	0 1	220...230	1 1	NORR63-01-CC	FPL7146116R0006	3.2
		-	1000	0	2	0 2		1 1	NORR63-02-CC	FPL7146216R0006	4.2
		1000	500	2	1	2 1		1 1	NORR63-21-CC	FPL7146516R0006	3.9
		1000	500	3	1	3 1		1 1	NORR63-31-CC	FPL7146716R0006	4.9
125	125	-	500	0	1	0 1	220...230	1 1	NORR125-01-CC	FPL7446115R0006	4.2
		-	1000	0	2	0 2		1 1	NORR125-02-CC	FPL7446215R0006	6.2
		1000	500	2	1	2 1		1 1	NORR125-21-CC	FPL7446515R0006	8.2
		1000	500	3	1	3 1		1 1	NORR125-31-CC	FPL7446715R0006	9
200	200	-	500	0	1	0 1	220...230	1 1	NORR200-01-CC	FPL7646115R0006	6.6
		-	1000	0	2	0 2		1 1	NORR200-02-CC	FPL7646215R0006	9.6
		1000	500	2	1	2 1		1 1	NORR200-21-CC	FPL7646515R0006	10
		1000	500	3	1	3 1		1 1	NORR200-31-CC	FPL7646715R0006	12.2
315	315	-	220	0	1	0 1	220...230	1 1	NORR400-01	FPL9445115R0006	9
		-	440	0	2	0 2		1 1	NORR400-02	FPL9445215R0006	12
		440	220	2	1	2 1		1 1	NORR400-21	FPL9445515R0006	15
		440	220	3	1	3 1		1 1	NORR400-31	FPL9445715R0006	18
800	720	-	500	0	1	0 1	220...230	1 1	NORR800-01-CC	FPL8646115R0006	28.6
		-	1000	0	2	0 2		1 1	NORR800-02-CC	FPL8646215R0006	40
		1000	500	2	1	2 1		1 1	NORR800-21-CC	FPL8646515R0006	51
		1500	500	3	1	3 1		1 1	NORR800-31-CC	FPL8646715R0006	62

DC operated

IEC		Rated operational current		voltage (3)		Number of poles (4)	Rated control circuit voltage U _c (1)	Auxiliary contacts fitted (2)	Type	Order code	Weight
DC-1	DC-3 DC-5	V DC	V DC	V DC	V DC						
A	A						V DC				kg
63	63	-	500	0	1	0 1	220	1 1	NORE63-01-CC	FPL7140116R0006	3.2
		-	1000	0	2	0 2		1 1	NORE63-02-CC	FPL7140216R0006	4.2
		1000	500	2	1	2 1		1 1	NORE63-21-CC	FPL7140516R0006	3.9
		1000	500	3	1	3 1		1 1	NORE63-31-CC	FPL7140716R0006	4.9
125	125	-	500	0	1	0 1	220	1 1	NORE125-01-CC	FPL7440115R0006	4.2
		-	1000	0	2	0 2		1 1	NORE125-02-CC	FPL7440215R0006	6.2
		1000	500	2	1	2 1		1 1	NORE125-21-CC	FPL7440515R0006	8.2
		1000	500	3	1	3 1		1 1	NORE125-31-CC	FPL7440715R0006	9
200	200	-	500	0	1	0 1	220	1 1	NORE200-01-CC	FPL7640115R0006	6.6
		-	1000	0	2	0 2		1 1	NORE200-02-CC	FPL7640215R0006	9.6
		1000	500	2	1	2 1		1 1	NORE200-21-CC	FPL7640515R0006	10
		1000	500	3	1	3 1		1 1	NORE200-31-CC	FPL7640715R0006	12.2
315	315	-	220	0	1	0 1	220	1 1	NORE400-01	FPL9449115R0006	9
		-	440	0	2	0 2		1 1	NORE400-02	FPL9449215R0006	12
		440	220	2	1	2 1		1 1	NORE400-21	FPL9449515R0006	15
		440	220	3	1	3 1		1 1	NORE400-31	FPL9449715R0006	18
800	720	-	500	0	1	0 1	220	1 1	NORE800-01-CC	FPL8640115R0006	28.6
		-	1000	0	2	0 2		1 1	NORE800-02-CC	FPL8640215R0006	40
		1000	500	2	1	2 1		1 1	NORE800-21-CC	FPL8640515R0006	51
		1500	500	3	1	3 1		1 1	NORE800-31-CC	FPL8640715R0006	62

(1) Other control voltages see voltage code table.

(2) Other auxiliary contact arrangements, see auxiliary contact code table.

(3) Please consult us for power circuit above:

- 1000 V DC for ratings 63...500 A

- 1500 V DC for ratings 800 A.

(4) Other main pole combinations, please consult us.

NORR63..MT ... NORR800..MT and NORE63..MT ... NORE800..MT contactors

Technical data

Main pole - Utilization characteristics according to IEC









Contactor types	AC operated	NORR63..MT	NORR125..MT	NORR200..MT	NORR800..MT	NORR400	NORR800	
	DC operated	NORE63..MT	NORE125..MT	NORE200..MT	NORE800..MT	NORE400	NORE800	
Standards	IEC 60947-1 / 60947-4-1 and EN 60947-1 / 60947-4-1							
Rated operational voltage Ue max.	690 V					500 V		
Rated frequency (without derating)	25...60 Hz (for > 60...400 Hz please consult us)							
Number of poles	2...4							
Conventional free-air thermal current Ith acc. to IEC 60947-4-1, open contactors, $\theta \leq 40\text{ }^\circ\text{C}$	63 A	125 A	200 A	800 A	315 A	800 A		
With conductor cross-sectional area	16 mm ²	50 mm ²	95 mm ²	500 mm ²	185 mm ²	500 mm ²		
AC-1 Utilization category For air temperature close to contactor								
Ie / Rated operational current AC-1 Ue max. $\leq 690\text{ V}$, 50/60 Hz	$\theta \leq 40\text{ }^\circ\text{C}$	63 A	125 A	200 A	800 A	315 A	800 A	
	$\theta \leq 55\text{ }^\circ\text{C}$	56 A	110 A	180 A	710 A	280 A	710 A	
	$\theta \leq 70\text{ }^\circ\text{C}$	50 A	100 A	160 A	640 A	250 A	640 A	
With conductor cross-sectional area	16 mm ²	50 mm ²	95 mm ²	500 mm ²	185 mm ²	500 mm ²		
Rated making capacity AC-1	1.5 x Ie AC-1 acc. to IEC 60947-4-1							
Rated breaking capacity AC-1	1.5 x Ie AC-1 acc. to IEC 60947-4-1							
AC-3 Utilization category For air temperature close to contactor $\theta \leq 55\text{ }^\circ\text{C}$								
Ie / Max. rated operational current AC-3								
								
	690 V	Please consult us						
Short-circuit protection device for contactors without thermal overload relay - Motor protection excluded								
Ue $\leq 1000\text{ V AC}$ - gG type fuse	80 A	160 A	250 A	1000 A	630 A	1000 A		
Ue $\leq 1000\text{ V AC}$ - L type fuse	-	-	-	-	-	-		
Rated short-time withstand current Icw	1 s	850 A	2250 A	3800 A	7500 A	5000 A	7500 A	
at 40 °C ambient temperature, in free air from a cold state	10 s	500 A	1280 A	2080 A	6000 A	2500 A	6000 A	
	30 s	250 A	680 A	1040 A	3000 A	1250 A	3000 A	
	1 min	230 A	450 A	730 A	2000 A	870 A	2000 A	
	15 min	120 A	250 A	390 A	1200 A	460 A	1200 A	
Impedance per pole	AC-1	1.8 m Ω	1.20 m Ω	0.60 m Ω	0.28 m Ω	0.40 m Ω	0.18 m Ω	
Maximum electrical switching frequency	AC-1	300 cycles/h				300 cycles/h		
Mechanical durability								
Number of operating cycles	3 millions cycles				1 million cycles		3 millions cycles	1 million cycles
Maximum switching frequency	1200 cycles/h					1200 cycles/h		

Note: These characteristics are suitable for NOR..MT-AMA and NOR..MT-AME contactors with latching versions (except for mechanical durability = 0.2 millions of operating cycles).

NORR63..CC ... NORR800..CC and NORE63..CC ... NORE800..CC contactors

Technical data

Main pole - Utilization characteristics according to IEC

Contactor types	AC operated	NORR63..CC	NORR125..CC	NORR200..CC	NORR800..CC	NORR400
	DC operated	NORE63..CC	NORE125..CC	NORE200..CC	NORE800..CC	NORE400
Standards	IEC 60947-1 / 60947-4-1 and EN 60947-1 / 60947-4-1					
Rated operational voltage U_e max.	1000 V DC (1500 V DC with increased insulation (1))					440 V DC
Number of poles	1...4					
Conventional free-air thermal current I_{th}						
acc. to IEC 60947-4-1, open contactors, $\theta \leq 40$ °C		63 A	125 A	200 A	800 A	315 A
With conductor cross-sectional area		16 mm ²	50 mm ²	95 mm ²	500 mm ²	185 mm ²
DC-1 Utilization category, L/R \leq 1 ms						
I_e / Rated operational current DC-1						
 1 pole	≤ 220 V	-	-	-	-	315 A
	≤ 500 V	63 A	125 A	200 A	800 A	-
 2 poles in series	≤ 440 V	-	-	-	-	315 A
	≤ 1000 V	63 A	125 A	200 A	800 A	-
	≤ 1500 V	-	-	-	800 A	-
 3 poles in series	≤ 1500 V (1)	63 A	125 A	200 A	800 A	-
DC-3 Utilization category, L/R \leq 2 ms						
I_e / Rated operational current DC-3						
 1 pole	≤ 220 V	-	-	-	-	315 A
	≤ 500 V	63 A	125 A	200 A	720 A	-
 2 poles in series	≤ 440 V	-	-	-	-	315 A
	≤ 1000 V	63 A	125 A	200 A	720 A	-
 3 poles in series	≤ 1500 V (1)	63 A	125 A	200 A	720 A	-
DC-5 Utilization category, L/R \leq 7.5 ms						
I_e / Rated operational current DC-5						
 1 pole	≤ 220 V	-	-	-	-	315 A
	≤ 500 V	63 A	125 A	200 A	720 A	-
 2 poles in series	≤ 440 V	-	-	-	-	315 A
	≤ 1000 V	63 A	125 A	200 A	720 A	-
 3 poles in series	≤ 1500 V (1)	63 A	125 A	200 A	720 A	-
Rated short-time withstand current I_{cw}	1 s	850 A	1700 A	3100 A	9000 A	5000 A
at 40 °C ambient temperature,	10 s	500 A	900 A	1600 A	6400 A	2500 A
in free air from a cold state	30 s	250 A	450 A	800 A	3200 A	1250 A
	1 min	170 A	310 A	560 A	2100 A	870 A
	15 min	90 A	180 A	300 A	1200 A	460 A
Rated breaking capacity						
(L/R \leq 15 ms)	1 pole 500 V	252 A	500 A	800 A	2880 A	1260 A (220 V)
	2 poles 1000 V	252 A	500 A	800 A	2880 A	1260 A (440 V)
	3 poles 1500 V	252 A	500 A	800 A	2880 A	-
Impedance per pole	1.8 m Ω					0.40 m Ω
Maximum electrical switching frequency	120 cycles/h					120 cycles/h
Mechanical durability						
Number of operating cycles	3 millions cycles			1 million cycles		3 million cycles
Maximum switching frequency	1200 cycles/h					1200 cycles/h

(1) NOR63 ... NOR200: version with increased insulation for 1000 V < U_e < 1500 V, please consult us.

Notes: - The arc switching on DC is more difficult than on AC

- For selecting a contactor, it is essential to determine the current, the voltage, and the L/R time constant of the controlled load
- For information, typical time constant values are quoted hereafter: non inductive loads such as resistance furnaces: L/R < 1 ms; inductive loads such as shunt motor: L/R < 2 ms; series motor: L/R < 7.5 ms
- The addition of a resistor in parallel with an inductive winding helps in the elimination of the arcs
- All the poles required for breaking must be connected, in series, between the load and the source polarity not linked to the earth
- Connection of the poles in series by the user, according to the above diagrams. The connection of the poles in series helps in the elimination of the arcs
- These characteristics are suitable for NOR..CC-AMA and NOR..CC-AME contactor latching versions (except for mechanical durability = 0.2 millions of operating cycles).

Power circuit coupling

LOR couplers



Description

LOR couplers are built without blowout coil and arc chutes. They are not suitable for breaking on-load at voltages above 24 V AC or DC.

- AC switching up to 1000 V AC
- DC switching up to:
 - 1000 V DC for R85 ... R550
 - 1500 V DC for R800 ... R5100

For other voltages, please consult us.

1 N.O and 1 N.C. auxiliary contacts are fitted as standard. For additional auxiliary contact, refer to "Auxiliary contact fitting details".

Example of use

- Automatic short-circuiting of the starting resistances of a slip-ring or DC motors without the possibility of opening on-load
- Electrolytic installations and electro-plating plants
- Induction furnaces (please consult us).

Other variants:

Please consult us for:

- LOR couplers with N.C. poles
- LOR..AMA and LOR..AME couplers with latching.

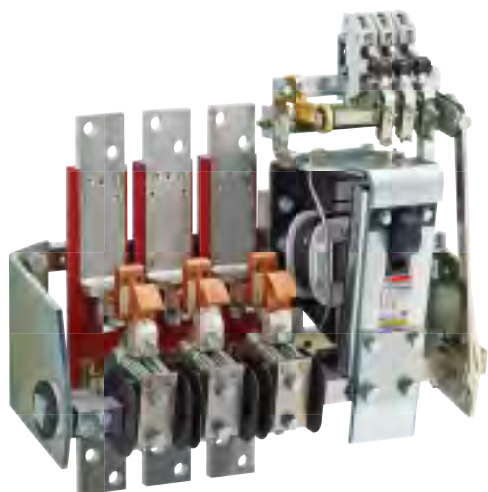

LORR couplers

Power circuit up to 1000 V AC or 1500 V DC

AC operated



LORR550-20

Description

- LORR are used for controlling:
- AC power circuits up to 1000 V AC
 - DC power circuits up to:
 - 1000 V DC for ratings 85...550 A
 - 1500 V DC for ratings 800...5100 A.

They are not suitable for breaking on-load at voltages above 24 V AC or DC.

- These contactors are designed with:
- variable number of poles according to the application
 - control circuit: AC operated
 - 1 N.O. and 1 N.C. auxiliary contacts available, as standard.

Ordering details

Conventional thermal current I _{th} (θ ≤ 40 °C)	Rated operational voltage		Number of poles	Rated control circuit voltage U _c (1)	Auxiliary contacts fitted (2)	Type	Order code	Weight pkg (1 pce) kg
	V AC	V DC (3)						
90	1000	1000	1	220...230	1 1	LORR85-10	FPL7235110R0006	2,6
			2		1 1	LORR85-20	FPL7235210R0006	3
			3		1 1	LORR85-30	FPL7235310R0006	3,4
			4		1 1	LORR85-40	FPL7235410R0006	3,8
185	1000	1000	1	220...230	1 1	LORR170-10	FPL7535110R0006	3,2
			2		1 1	LORR170-20	FPL7535210R0006	4,1
			3		1 1	LORR170-30	FPL7535310R0006	5
			4		1 1	LORR170-40	FPL7535410R0006	5,9
300	1000	1000	1	220...230	1 1	LORR260-10	FPL7835110R0006	4,7
			2		1 1	LORR260-20	FPL7835210R0006	5,9
			3		1 1	LORR260-30	FPL7835310R0006	7,1
			4		1 1	LORR260-40	FPL7835410R0006	8,3
420	1000	1000	1	220...230	1 1	LORR400-10	FPL9435110R0006	11,4
			2		1 1	LORR400-20	FPL9435210R0006	14,7
			3		1 1	LORR400-30	FPL9435310R0006	18
			4		1 1	LORR400-40	FPL9435410R0006	21,3
630	1000	1000	1	220...230	1 1	LORR550-10	FPL8435110R0006	11,4
			2		1 1	LORR550-20	FPL8435210R0006	14,7
			3		1 1	LORR550-30	FPL8435310R0006	18
			4		1 1	LORR550-40	FPL8435410R0006	21,3
1100	1000	1000	220...230	1 1	LORR800-10	FPL8635110R0006	29	
		1500		1 1	LORR800-20	FPL8635210R0006	34	
		1500		1 1	LORR800-30	FPL8635310R0006	42	
		1500		1 1	LORR800-40	FPL8635410R0006	54	
1400	1000	1000	220...230	1 1	LORR1400-10	FPL6135110R0006	30	
		1500		1 1	LORR1400-20	FPL6135210R0006	36	
		1500		1 1	LORR1400-30	FPL6135310R0006	44	
		1500		1 1	LORR1400-40	FPL6135410R0006	56	
1700	1000	1000	220...230	1 1	LORR1700-10	FPL6235110R0006	34	
		1500		1 1	LORR1700-20	FPL6235210R0006	42	
		1500		1 1	LORR1700-30	FPL6235310R0006	50	
		1500		1 1	LORR1700-40	FPL6235410R0006	66	
2100	1000	1000	220...230	1 1	LORR2100-10	FPL6335110R0006	36	
		1500		1 1	LORR2100-20	FPL6335210R0006	44	
		1500		1 1	LORR2100-30	FPL6335310R0006	52	
		1500		1 1	LORR2100-40	FPL6335410R0006	68	
2500	1000	1000	220...230	1 1	LORR2500-10	FPL6735110R0006	On request	
		1500		1 1	LORR2500-20	FPL6735210R0006		
		1500		1 1	LORR2500-30	FPL6735310R0006		
		1500		1 1	LORR2500-40	FPL6735410R0006		
3200	1000	1000	220...230	1 1	LORR3200-10	FPL6535110R0006	On request	
		1500		1 1	LORR3200-20	FPL6535210R0006		
		1500		1 1	LORR3200-30	FPL6535310R0006		
		1500		1 1	LORR3200-40	FPL6535001R0006		
3800	1000	1000	220...230	1 1	LORR3800-10	FPL6635110R0006	On request	
		1500		1 1	LORR3800-20	FPL6635210R0006		
		1500		1 1	LORR3800-30	FPL6635002R0006		
		1500		1 1	LORR3800-40	FPL6635003R0006		
4500	1000	1000	220...230	1 1	LORR4500-10	FPL6835110R0006	On request	
		1500		1 1	LORR4500-20	FPL6835210R0006		
		1500		1 1	LORR4500-30	FPL6835001R0006		
5100	1000	1000	220...230	1 1	LORR5100-10	FPL6935110R0006	On request	
		1500		1 1	LORR5100-20	FPL6935001R0006		

(1) Other control voltages see voltage code table.
 (2) Other auxiliary contact arrangements, see auxiliary contact code table.
 (3) Please consult us for power circuit above 1000 V AC or 1500 V DC.

LORE couplers

Power circuit up to 1000 V AC or 1000 V DC

DC operated

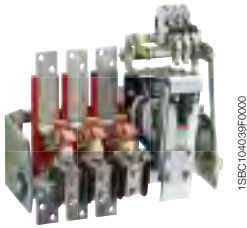

LORE800-30

Description

LORE couplers are used for controlling:

- AC power circuits up to 1000 V AC
- DC power circuits up to:
 - 1000 V DC for ratings 85...550 A
 - 1500 V DC for ratings 800...5100 A.

They are not suitable for breaking on-load at voltages above 24 V AC or DC.

These contactors are designed with:

- variable number of poles according to the application
- control circuit: DC operated
- 1 N.O. and 1 N.C. auxiliary contacts available, as standard.

Ordering details

Conventional thermal current I _{th} (θ ≤ 40 °C)	Rated operational voltage		Number of poles	Rated control circuit voltage U _c (1)	Auxiliary contacts fitted (2)	Type	Order code	Weight
	V AC	V DC (3)						
90	1000	1000	1	220	1 1	LORE85-10	FPL7239110R0006	2.6
			2		1 1	LORE85-20	FPL7239210R0006	3
			3		1 1	LORE85-30	FPL7239310R0006	3.4
			4		1 1	LORE85-40	FPL7239410R0006	3.8
185	1000	1000	1	220	1 1	LORE170-10	FPL7539110R0006	3.2
			2		1 1	LORE170-20	FPL7539210R0006	4.1
			3		1 1	LORE170-30	FPL7539310R0006	5
			4		1 1	LORE170-40	FPL7539410R0006	5.9
300	1000	1000	1	220	1 1	LORE260-10	FPL7839110R0006	4.7
			2		1 1	LORE260-20	FPL7839210R0006	5.9
			3		1 1	LORE260-30	FPL7839310R0006	7.1
			4		1 1	LORE260-40	FPL7839410R0006	8.3
420	1000	1000	1	220	1 1	LORE400-10	FPL9439110R0006	11.4
			2		1 1	LORE400-20	FPL9439210R0006	14.7
			3		1 1	LORE400-30	FPL9439310R0006	18
			4		1 1	LORE400-40	FPL9439410R0006	21.3
630	1000	1000	1	220	1 1	LORE550-10	FPL8439110R0006	11.4
			2		1 1	LORE550-20	FPL8439210R0006	14.7
			3		1 1	LORE550-30	FPL8439310R0006	18
			4		1 1	LORE550-40	FPL8439410R0006	21.3
1100	1000	1000	1	220	1 1	LORE800-10	FPL8639110R0006	29
		1500	2		1 1	LORE800-20	FPL8639210R0006	34
		1500	3		1 1	LORE800-30	FPL8639310R0006	42
		1500	4		1 1	LORE800-40	FPL8639410R0006	54
1400	1000	1000	1	220	1 1	LORE1400-10	FPL6139110R0006	30
		1500	2		1 1	LORE1400-20	FPL6139210R0006	36
		1500	3		1 1	LORE1400-30	FPL6139310R0006	44
		1500	4		1 1	LORE1400-40	FPL6139410R0006	56
1700	1000	1000	1	220	1 1	LORE1700-10	FPL6239110R0006	34
		1500	2		1 1	LORE1700-20	FPL6239210R0006	42
		1500	3		1 1	LORE1700-30	FPL6239310R0006	50
		1500	4		1 1	LORE1700-40	FPL6239410R0006	66
2100	1000	1000	1	220	1 1	LORE2100-10	FPL6339110R0006	36
		1500	2		1 1	LORE2100-20	FPL6339210R0006	44
		1500	3		1 1	LORE2100-30	FPL6339310R0006	52
		1500	4		1 1	LORE2100-40	FPL6339410R0006	68
2500	1000	1000	1	220	1 1	LORE2500-10	FPL6739110R0006	On request
		1500	2		1 1	LORE2500-20	FPL6739210R0006	
		1500	3		1 1	LORE2500-30	FPL6739310R0006	
		1500	4		1 1	LORE2500-40	FPL6739410R0006	
3200	1000	1000	1	220	1 1	LORE3200-10	FPL6539110R0006	On request
		1500	2		1 1	LORE3200-20	FPL6539210R0006	
		1500	3		1 1	LORE3200-30	FPL6539310R0006	
		1500	4		1 1	LORE3200-40	FPL6539001R0006	
3800	1000	1000	1	220	1 1	LORE3800-10	FPL6639110R0006	On request
		1500	2		1 1	LORE3800-20	FPL6639210R0006	
		1500	3		1 1	LORE3800-30	FPL6639002R0006	
		1500	4		1 1	LORE3800-40	FPL6639003R0006	
4500	1000	1000	1	220	1 1	LORE4500-10	FPL6839110R0006	On request
		1500	2		1 1	LORE4500-20	FPL6839210R0006	
		1500	3		1 1	LORE4500-30	FPL6839001R0006	
5100	1000	1000	1	220	1 1	LORE5100-10	FPL6939110R0006	On request
		1500	2		1 1	LORE5100-20	FPL6939001R0006	

(1) Other control voltages see voltage code table.

(2) Other auxiliary contact arrangements, see auxiliary contact code table.

(3) Please consult us for power circuit above 1000 V AC or 1500 V DC.

LORR85 ... LORR550 and LORE85 ... LORE550 couplers

Technical data

Main pole - Utilization characteristics according to IEC

Couplers types	AC operated	LORR85	LORR170	LORR260	LORR400	LORR550
	DC operated	LORE85	LORE170	LORE260	LORE400	LORE550
Standards	IEC 60947-1 / 60947-4-1 and EN 60947-1 / 60947-4-1					
Rated operational voltage U_e max.	1000 V					
Rated frequency (without derating)	25...60 Hz (for > 60...400 Hz please contact us)					
Number of poles	1...4					
Conventional free-air thermal current I_{th}						
acc. to IEC 60947-4-1, open couplers, $\theta \leq 40\text{ }^\circ\text{C}$	90 A	185 A	300 A	420 A	630 A	
With conductor cross-sectional area	35 mm ²	95 mm ²	185 mm ²	300 mm ²	400 mm ²	
AC-1 / DC-1 Utilization category						
For air temperature close to couplers						
I_e / Rated operational current AC-1 / DC-1	$\theta \leq 40\text{ }^\circ\text{C}$	90 A	185 A	300 A	420 A	630 A
U _e max. $\leq 690\text{ V}$, 50/60 Hz	$\theta \leq 55\text{ }^\circ\text{C}$	82 A	170 A	270 A	370 A	570 A
	$\theta \leq 70\text{ }^\circ\text{C}$	72 A	150 A	240 A	330 A	500 A
With conductor cross-sectional area		35 mm ²	95 mm ²	185 mm ²	300 mm ²	400 mm ²
Rated making capacity AC-1 / DC-1	1000 V max.	1.5 x I _e / AC-1 or DC-1 acc. to IEC 60947-4-1				
Rated breaking capacity AC-1 / DC-1	24 V max.	1.5 x I _e / AC-1 or DC-1 acc. to IEC 60947-4-1				
Short-circuit protection device for couplers						
without thermal overload relay - Motor protection excluded						
U _e $\leq 1000\text{ V AC}$ - gG type fuse	100 A	200 A	315 A	500 A	700 A	
U _e $\leq 1000\text{ V AC}$ - L type fuse	-	-	-	-	-	
Rated short-time withstand current I_{cw}						
at 40 °C ambient temperature,	1 s	1150 A	2250 A	3800 A	6000 A	8400 A
in free air from a cold state	10 s	680 A	1200 A	1920 A	2960 A	4400 A
	30 s	310 A	680 A	1040 A	1480 A	2200 A
	1 min	230 A	450 A	730 A	1100 A	1680 A
	15 min	120 A	250 A	390 A	600 A	840 A
Impedance per pole		1.80 m Ω	1.20 m Ω	0.60 m Ω	0.40 m Ω	0.35 m Ω
Maximum electrical switching frequency	AC-1	300 cycles/h				
Mechanical durability						
Number of operating cycles	5 millions cycles					
Maximum switching frequency	1200 cycles/h					

Note: - Technical data applicable for N.O. main poles. For N.C. main poles, please consult us.

- These characteristics are suitable for LOR..AMA and LOR..AME contactor versions (except for mechanical durability = 0.2 millions of operating cycles).



LORR800 ... LORR5100 and LORE800 ... LORE5100 couplers

Technical data

Main pole - Utilization characteristics according to IEC

Couplers types	AC operated	LORR800	LORR1400	LORR1700	LORR2100	LORR2500	LORR3200	LORR3800	LORR4500	LORR5100
	DC operated	LORE800	LORE1400	LORE1700	LORE2100	LORE2500	LORE3200	LORE3800	LORE4500	LORE5100
Standards	IEC 60947-1 / 60947-4-1 and EN 60947-1 / 60947-4-1									
Rated operational voltage Ue max.	1000 V									
Rated frequency (without derating)	25...60 Hz (for > 60...400 Hz please consult us)									
Number of poles	1...4									
Conventional free-air thermal current Ith acc. to IEC 60947-4-1, open couplers, $\theta \leq 40^\circ\text{C}$ With conductor cross-sectional area	1100 A 800 mm ²	1400 A 1000 mm ²	1700 A 1500 mm ²	2100 A 1500 mm ²	2500 A 2000 mm ²	3200 A 3000 mm ²	3800 A 3000 mm ²	4500 A 4000 mm ²	5100 A 4000 mm ²	
AC-1 / DC-1 Utilization category For air temperature close to couplers										
Ie / Rated operational current AC-1 / DC-1										
$\theta \leq 40^\circ\text{C}$	1100 A	1400 A	1700 A	2100 A	2500 A	3200 A	3800 A	4500 A	5100 A	
$\theta \leq 55^\circ\text{C}$	1000 A	1230 A	1500 A	1840 A	2200 A	2800 A	3330 A	3950 A	4470 A	
$\theta \leq 70^\circ\text{C}$	900 A	1030 A	1250 A	1540 A	1830 A	2350 A	2780 A	3300 A	3740 A	
With conductor cross-sectional area	800 mm ²	1000 mm ²	1500 mm ²	1500 mm ²	2000 mm ²	3000 mm ²	3000 mm ²	4000 mm ²	4000 mm ²	
Rated making capacity AC-1 / DC-1	1000 V max.	1.5 x Ie / AC-1 or DC-1 acc. to IEC 60947-4-1								
Rated breaking capacity AC-1 / DC-1	24 V max.	1.5 x Ie / AC-1 or DC-1 acc. to IEC 60947-4-1								
Short-circuit protection device for couplers without thermal overload relay - Motor protection excluded Ue \leq 1000 V AC - Circuit breaker		1250 A	1600 A	2000 A	2500 A	-	-	-	-	-
Rated short-time withstand current Icw at 40 °C ambient temperature, in free air from a cold state										
1 s	9000 A	11000 A	13000 A	15000 A	20000 A	21000 A	24000 A	28000 A	29000 A	
10 s	8000 A	9000 A	11000 A	12200 A	15000 A	18000 A	19000 A	21000 A	22000 A	
30 s	4000 A	5000 A	6000 A	7000 A	8000 A	10000 A	11000 A	12000 A	13000 A	
1 min	3000 A	3700 A	4400 A	5000 A	6000 A	7000 A	7500 A	8000 A	8500 A	
15 min	1600 A	2000 A	2400 A	2800 A	3000 A	4000 A	4500 A	5000 A	5500 A	
Impedance per pole		0.18 m Ω	0.10 m Ω	0.090 m Ω	0.080 m Ω	0.05 m Ω	0.045 m Ω	0.04 m Ω	0.03 m Ω	0.027 m Ω
Maximum electrical switching frequency	AC-1	300 cycles/h	150 cycles/h	120 cycles/h		60 cycles/h		40 cycles/h		
Mechanical durability						2 millions cycles		1 million cycles		
Number of operating cycles		5 millions cycles				2 millions cycles		1 million cycles		
Maximum switching frequency		1200 cycles/h				600 cycles/h		300 cycles/h		

Note: - Technical data applicable for N.O. main poles. For N.C. main poles, please consult us.

- These characteristics are suitable for LOR..AME contactor versions (except for mechanical durability = 0.2 millions of operating cycles).



Slip-ring motor control with rheostats FOR contactors

Application

Three kinds of contactors are used to control three-phase slip-ring motors: the stator contactor, the acceleration contactor(s), and the rotor short-circuit contactor.

Example of a three-stroke starter (star (Y) connection diagram)

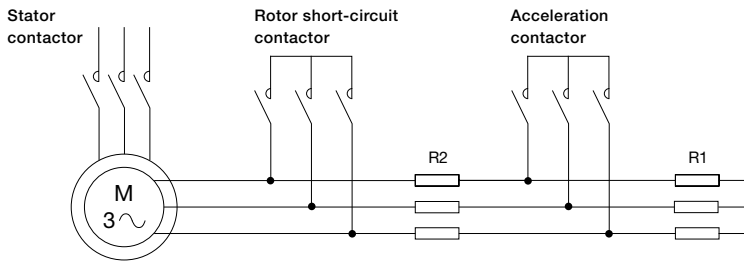

5

The starting resistances should be star (Y) or V connected acc. to the following wiring diagrams. Contactors have to be selected accordingly.

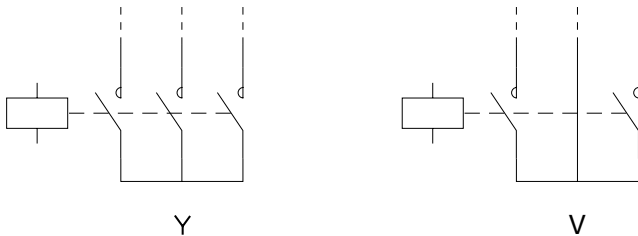

Stator contactor

The standard R contactor selection is based on the motor rated current acc. to the AC-2 utilization category, as well as on the rated operational voltage and the on-load factor.

Acceleration contactor and rotor short-circuit contactor

FOR contactor selection is based on the contactor rated operational current I_e acc. to the AC-1 utilization category.

At the time of slip-ring motor starting and as soon as the motor nominal speed is reached, these contactors are used for the short-circuiting of the rotor current limitation starting resistances (e.g. vapour-liquid rheostats).

These contactors are derived from the standard R contactors and are available in 2, 3, 4 or 6-pole versions acc. to the applicable connection diagram required (Y, V).

They can control rotor currents up to 3800 A and rotor voltages up to 4200 V (with increased insulation) acc. to the IEC 60947-4-1 standard requirements. For rotor voltages ≥ 4200 V, please consult us.

Although the breaking of the rotor circuit is normally carried out in "off-load" conditions, the contactors are equipped with blow-out devices and can occasionally break "on-load".

Ordering details, dimensions : please consult us.

The LOR couplers may be used for applications where equipment is breaking in "Off-load" conditions only.

Slip-ring motor control with variable frequency drive FOR contactors

Application

This variant is used to start a slip-ring motor which will be then controlled by a variable frequency drive.

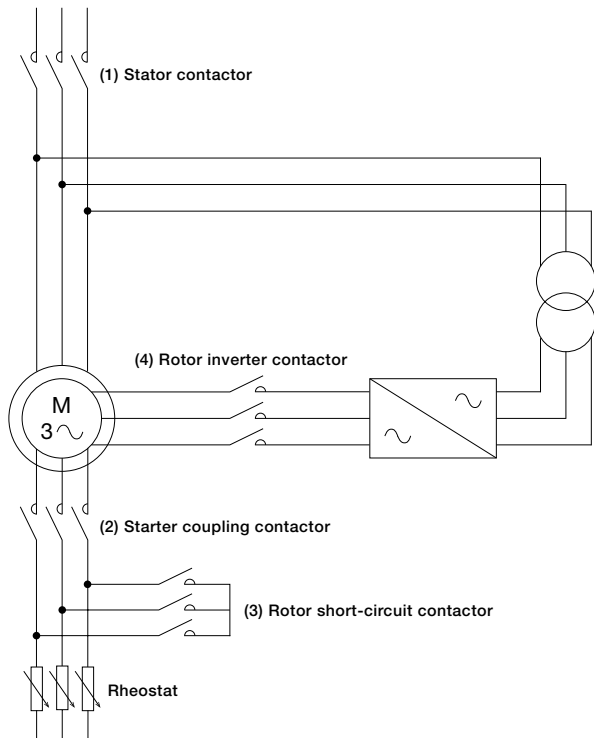

Description

A liquid rheostat is used to start and accelerate the motor after closing of the starter coupling contactor (2) and then the stator contactor (1). When the nominal speed is reached, the rotor short-circuit contactor (3) closes.

Then the rotor inverter contactor closes (4) and the starter coupling contactor (2) opens.

The speed of the motor is controlled by the variable frequency drive.

FOR contactors are suitable for starter coupling (2), rotor short-circuiting (3) and rotor inverter (4) contactor. IOR contactors must be used for stator contactor (1).

FORR1000 ... FORR3800 and FORE1000 ... FORE3800 contactors

Rotor voltages up to 1500 V AC

Main pole - Utilization characteristics according to IEC (Y and V connection diagram)

Contactor types	AC operated	FORR1000	FORR1400	FORR1700	FORR2100	FORR2500	FORR3200	FORR3800
	DC operated	FORE1000	FORE1400	FORE1700	FORE2100	FORE2500	FORE3200	FORE3800
Rated rotor operational voltage U_{er}		1500 V						
Rated frequency (without derating)		0.1...60 Hz (for > 60 Hz consult us)						
Conventional free-air thermal current I_{th}								
acc. to IEC 60947-4-1, $\theta \leq 40\text{ °C}$		1000 A	1400 A	1700 A	2100 A	2500 A	3200 A	3800 A
With conductor cross-sectional area		600 mm ²	1000 mm ²	1500 mm ²	2000 mm ²	2000 mm ²	3000 mm ²	3000 mm ²
Rated rotor operational current I_{er}								
For air temperature close to contactor								
$\theta \leq 40\text{ °C}$		1000 A	1400 A	1700 A	2100 A	2500 A	3200 A	3800 A
$\theta \leq 55\text{ °C}$		930 A	1180 A	1450 A	1750 A	2200 A	2800 A	3200 A
$\theta \leq 70\text{ °C}$		800 A	1000 A	1250 A	1500 A	1830 A	2350 A	2780 A
With conductor cross-sectional area		600 mm ²	1000 mm ²	1500 mm ²	2000 mm ²	2000 mm ²	3000 mm ²	3000 mm ²
Maximum making capacity		14000 A	19000 A	21000 A	24000 A	24000 A	26000 A	29000 A
Maximum breaking capacity at $\cos \phi = 0.80$ and 1000 V		1500 A	2100 A	2600 A	3200 A	3800 A	4800 A	5700 A
Rated short-time withstand current I_{cw}								
at 40 °C ambient temperature, in free air from a cold state								
	1 s	9000 A	11000 A	13000 A	15000 A	20000 A	21000 A	24000 A
	10 s	8000 A	9000 A	11000 A	12200 A	15000 A	18000 A	19000 A
	30 s	4000 A	5000 A	6000 A	7000 A	8000 A	10000 A	11000 A
	1 min	3000 A	3700 A	4400 A	5000 A	6000 A	7000 A	7500 A
	15 min	1600 A	2000 A	2400 A	2800 A	3000 A	4000 A	4500 A
Impedance per pole		0.18 m Ω	0.10 m Ω	0.09 m Ω	0.08 m Ω	0.05 m Ω	0.045 m Ω	0.04 m Ω
Maximum electrical switching frequency		120 cycles/h						
Mechanical durability								
Number of operating cycles		5 millions cycles	2 millions cycles					
Max. switching frequency		600 cycles/h						

Note: Altitude \geq 2000 m, dimension drawings: please consult us.



FORR1000S ... FORR2100S and FORE1000S ... FORE2100S contactors

Rotor voltages up to 2500 V AC

Main pole - Utilization characteristics according to IEC (Y and V connection diagram)

Contactor types	AC operated	FORR1000S	FORR1400S	FORR1700S	FORR2100S	FORR2500S	FORR3200S	FORR3800S
	DC operated	FORE1000S	FORE1400S	FORE1700S	FORE2100S	FORE2500S	FORE3200S	FORE3800S
Rated rotor operational voltage U_{er}		2500 V						
Rated frequency (without derating)		0.1...60 Hz (for > 60 Hz consult us)						
Conventional free-air thermal current I_{th} acc. to IEC 60947-4-1, $\theta \leq 40$ °C With conductor cross-sectional area		1000 A	1400 A	1700 A	2100 A	2500 A	3200 A	3800 A
		600 mm ²	1000 mm ²	1500 mm ²	2000 mm ²	2000 mm ²	3000 mm ²	3000 mm ²
Rated rotor operational current I_{er} For air temperature close to contactor								
	$\theta \leq 40$ °C	1000 A	1400 A	1700 A	2100 A	2500 A	3200 A	3800 A
	$\theta \leq 55$ °C	930 A	1180 A	1450 A	1750 A	2200 A	2800 A	3200 A
	$\theta \leq 70$ °C	800 A	1000 A	1250 A	1500 A	1830 A	2350 A	2780 A
With conductor cross-sectional area		600 mm ²	1000 mm ²	1500 mm ²	2000 mm ²	2000 mm ²	3000 mm ²	3000 mm ²
Maximum making capacity		14000 A	19000 A	21000 A	24000 A	24000 A	26000 A	29000 A
Maximum breaking capacity at $\cos \phi = 0.80$ and 1000 V		1500 A	2100 A	2600 A	3200 A	3800 A	4800 A	5700 A
Rated short-time withstand current I_{cw} at 40 °C ambient temperature, in free air from a cold state	1 s	9000 A	11000 A	13000 A	15000 A	20000 A	21000 A	24000 A
	10 s	8000 A	9000 A	11000 A	12200 A	15000 A	18000 A	19000 A
	30 s	4000 A	5000 A	6000 A	7000 A	8000 A	10000 A	11000 A
	1 min	3000 A	3700 A	4400 A	5000 A	6000 A	7000 A	7500 A
	15 min	1600 A	2000 A	2400 A	2800 A	3000 A	4000 A	4500 A
Impedance per pole		0.18 m Ω	0.10 m Ω	0.09 m Ω	0.08 m Ω	0.05 m Ω	0.045 m Ω	0.04 m Ω
Maximum electrical switching frequency		120 cycles/h						
Mechanical durability								
	Number of operating cycles	5 millions cycles	2 millions cycles					
	Max. switching frequency	600 cycles/h						

Note: Altitude ≥ 2000 m, dimension drawings: please consult us.



FORR1000NSP ... FORR2100NSP and FORE1000NSP ... FORE2100NSP contactors

Rotor voltages up to 3500 V AC

Main pole - Utilization characteristics according to IEC (Y and V connection diagram)

Contactor types	AC operated	FORR1000NSP	FORR1400NSP	FORR1700NSP	FORR2100NSP	FORR2500NSP	FORR3200NSP	FORR3800NSP
	DC operated	FORE1000NSP	FORE1400NSP	FORE1700NSP	FORE2100NSP	FORE2500NSP	FORE3200NSP	FORE3800NSP
Rated rotor operational voltage U_{er}		3500 V						
Rated frequency (without derating)		0.1...60 Hz (for > 60 Hz consult us)						
Conventional free-air thermal current I_{th} acc. to IEC 60947-4-1, $\theta \leq 40\text{ °C}$ With conductor cross-sectional area		1000 A	1400 A	1700 A	2100 A	2500 A	3200 A	3800 A
		600 mm ²	1000 mm ²	1500 mm ²	2000 mm ²	2000 mm ²	3000 mm ²	3000 mm ²
Rated rotor operational current I_{er} For air temperature close to contactor								
	$\theta \leq 40\text{ °C}$	1000 A	1400 A	1700 A	2100 A	2500 A	3200 A	3800 A
	$\theta \leq 55\text{ °C}$	930 A	1180 A	1450 A	1750 A	2200 A	2800 A	3200 A
	$\theta \leq 70\text{ °C}$	800 A	1000 A	1250 A	1500 A	1830 A	2350 A	2780 A
	With conductor cross-sectional area	600 mm ²	1000 mm ²	1500 mm ²	2000 mm ²	2000 mm ²	3000 mm ²	3000 mm ²
Maximum making capacity		14000 A	19000 A	21000 A	24000 A	24000 A	26000 A	29000 A
Maximum breaking capacity at $\cos \phi = 0.80$ and 1000 V		1500 A	2100 A	2600 A	3200 A	3800 A	4800 A	5700 A
		9000 A	11000 A	13000 A	15000 A	20000 A	21000 A	24000 A
Rated short-time withstand current I_{cw} at 40 °C ambient temperature, in free air from a cold state	1 s	9000 A	11000 A	13000 A	15000 A	20000 A	21000 A	24000 A
	10 s	8000 A	9000 A	11000 A	12200 A	15000 A	18000 A	19000 A
	30 s	4000 A	5000 A	6000 A	7000 A	8000 A	10000 A	11000 A
	1 min	3000 A	3700 A	4400 A	5000 A	6000 A	7000 A	7500 A
	15 min	1600 A	2000 A	2400 A	2800 A	3000 A	4000 A	4500 A
Impedance per pole		0.18 m Ω	0.10 m Ω	0.09 m Ω	0.08 m Ω	0.05 m Ω	0.045 m Ω	0.04 m Ω
Maximum electrical switching frequency		120 cycles/h						
Mechanical durability								
	Number of operating cycles	5 millions cycles		2 millions cycles				
	Max. switching frequency	600 cycles/h						

Note: Altitude ≥ 2000 m, dimension drawings: please consult us.



FORR1000SPE ... FORR2100SPE and FORE1000SPE ... FORE2100SPE contactors

Rotor voltages up to 4200 V AC

Main pole - Utilization characteristics according to IEC (Y only connection diagram)

Contactor types	AC operated	FORR1000SPE	FORR1400SPE	FORR1700SPE	FORR2100SPE	FORR2500SPE	FORR3200SPE	FORR3800SPE	
	DC operated	FORE1000SPE	FORE1400SPE	FORE1700SPE	FORE2100SPE	FORE2500SPE	FORE3200SPE	FORE3800SPE	
Rated rotor operational voltage U_{er}	4200 V								
Rated frequency (without derating)	0.1...60 Hz (for > 60 Hz consult us)								
Conventional free-air thermal current I_{th} acc. to IEC 60947-4-1, $\theta \leq 40^\circ\text{C}$ With conductor cross-sectional area	1000 A	1400 A	1700 A	2100 A	2500 A	3200 A	3800 A		
	600 mm ²	1000 mm ²	1500 mm ²	2000 mm ²	2000 mm ²	3000 mm ²	3000 mm ²		
Rated rotor operational current I_{er} For air temperature close to contactor	$\theta \leq 40^\circ\text{C}$	1000 A	1400 A	1700 A	2100 A	2500 A	3200 A	3800 A	
	$\theta \leq 55^\circ\text{C}$	930 A	1180 A	1450 A	1750 A	2200 A	2800 A	3200 A	
	$\theta \leq 70^\circ\text{C}$	800 A	1000 A	1250 A	1500 A	1830 A	2350 A	2780 A	
	With conductor cross-sectional area	600 mm ²	1000 mm ²	1500 mm ²	2000 mm ²	2000 mm ²	3000 mm ²	3000 mm ²	
Maximum making capacity	14000 A	19000 A	21000 A	24000 A	24000 A	26000 A	29000 A		
Maximum breaking capacity at $\cos \phi = 0.80$ and 1000 V	1500 A	2100 A	2600 A	3200 A	3800 A	4800 A	5700 A		
Rated short-time withstand current I_{cw} at 40 °C ambient temperature, in free air from a cold state	1 s	9000 A	11000 A	13000 A	15000 A	20000 A	21000 A	24000 A	
	10 s	8000 A	9000 A	11000 A	12200 A	15000 A	18000 A	19000 A	
	30 s	4000 A	5000 A	6000 A	7000 A	8000 A	10000 A	11000 A	
	1 min	3000 A	3700 A	4400 A	5000 A	6000 A	7000 A	7500 A	
	15 min	1600 A	2000 A	2400 A	2800 A	3000 A	4000 A	4500 A	
Impedance per pole	0.18 m Ω	0.10 m Ω	0.09 m Ω	0.08 m Ω	0.05 m Ω	0.045 m Ω	0.04 m Ω		
Maximum electrical switching frequency	120 cycles/h								
Mechanical durability	Number of operating cycles	5 millions cycles	2 millions cycles						
	Max. switching frequency	600 cycles/h							

Note: - $U_{er} > 4200$ V AC, please consult us.
- Altitude ≥ 2000 m, dimension drawings: please consult us.



Closed transition star-delta starting of three-phase asynchronous motors

R contactor selection

Application

R contactors can be used for closed transition star-delta starting of three-phase asynchronous motors up to 1300 kW.

Description

This starting method, mainly used for large motor powers, prevents the speed drop during the "star-delta" transition time and maintains the resulting current peak at a relatively low value.

For this purpose the extra **KM4** transition contactor closes first before the **KM2** star contactor opens. When the **KM4** contactor closes, the motor windings are automatically delta connected, via resistances, to compensate the lack of current during the transition time. Thus the motor speed remains basically the same. The final delta connection step is then achieved by the **KM3** delta contactor closing which switches-off the coil supply to the **KM4** transition contactor. As in the basic star-delta starting mode, the closed transition star-delta starting mode is restricted to low resistive torque machines.

It is advisable, especially for big masses of inertia, to observe that the connection is made in acc. to the clockwise or anticlockwise rotation direction, as indicated in the block diagram shown below, in order to prevent damages due to torque throbs.

5 Equipment sizing

- **KM1** main contactor and **KM3** delta contactor: rating = $0.58 \times I_n$ for both contactors
- **KM2** star contactor: compared with a star contactor that would be used for a basic open transition star-delta starter the present **KM2** star contactor has to be over-rated as it is intended to break the star current ($0.34 \times I_n$) and the transition current too.
- **KM4** transition contactor: the rating is based on the calculation of the short permissible current duration (I_{cw}). The value of the current flow is about $1.5 \times I_n$ and the current flow duration < 100 ms. A block type contactor in the AF series can be selected for this step.
- Transition resistances: empiric value, generally as follows, $R (\Omega) = \frac{0.4 \times U_e}{I_n}$

Watt dissipation values for the transition resistances:

- for 12 cycles/h max. $P (W) = \frac{U_e^2}{1200 \times R}$

- for 30 cycles/h max. $P (W) = \frac{U_e^2}{500 \times R}$

Block Diagram

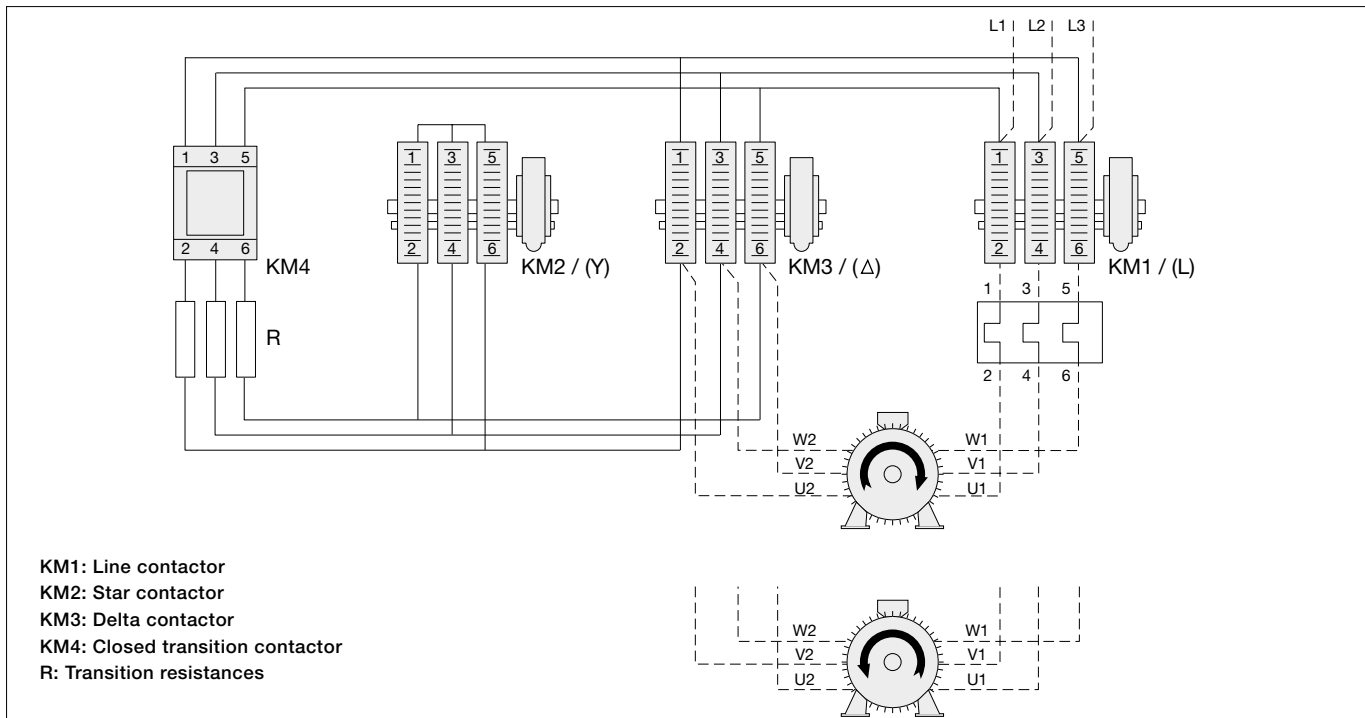

Autotransformer starters

General

An autotransformer starter allows to start a squirrel cage motor with a reduced starting current due to the reduced voltage within the accelerating duration.

At the contrary of the star-delta wiring, this autotransformer starting method needs three wires and three terminals on the motor.

At the starting period, the motor is wired to the auto-transformer taps: the "KM3" star contactor and the "KM2" autotransformer contactor are closed, the motor is under reduced voltage. Consequently, the torque is reduced as the square of the applied voltage. The autotransformers are generally equipped of three taps at each phase in order to adapt the starting parameters to the field requirements. When the motor reaches 80...95% of its nominal speed, the star contactor opens. Then, the "KM1" line contactor is making and the autotransformer contactor is opening. This starting process is done without any network interruption.

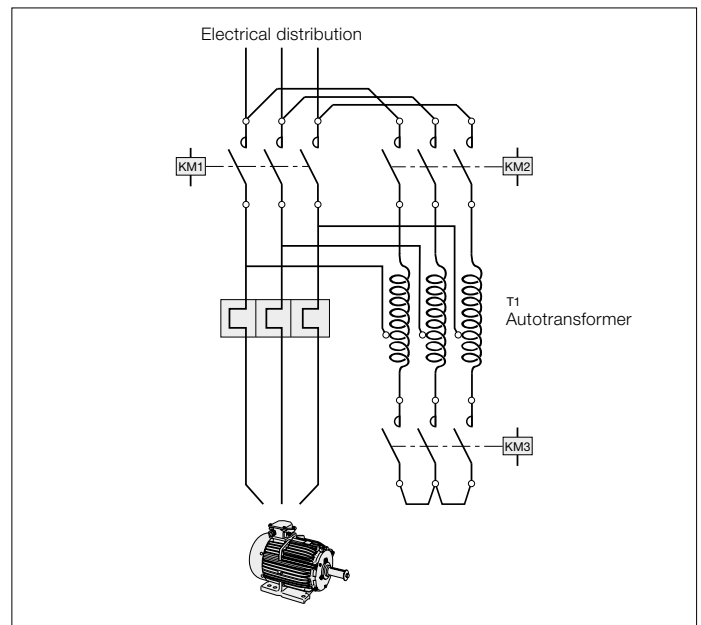

Selection table (I_d starting current / I_n nominal current < 8 - Acceleration time < 20 s - 30 cycles / h max.)

Motor ratings 50/60 Hz 440 V kW	Contactors		Autotransformer taps						
	KM1 Line	KM2	90 %			80 %			60-70 %
			90 %	80 %	70 %	60 %	90 %	80 %	
500	IOR..800	IOR..800	IOR..500..MT	IOR..400..MT	IOR..400..MT	IOR..200..MT	IOR..400..MT	IOR..500..MT	
560	IOR..1400	IOR..800	IOR..500..MT	IOR..500..MT	IOR..400..MT	IOR..200..MT	IOR..400..MT	IOR..500..MT	
630	IOR..1400	IOR..800	IOR..800	IOR..500..MT	IOR..400..MT	IOR..200..MT	IOR..400..MT	IOR..800	
710	IOR..1400	IOR..1400	IOR..800	IOR..500..MT	IOR..400..MT	IOR..200..MT	IOR..500..MT	IOR..800	
800	IOR..1700	IOR..1400	IOR..800	IOR..800	IOR..500..MT	IOR..400..MT	IOR..500..MT	IOR..800	
900	IOR..2100	IOR..1700	IOR..1400..MT	IOR..800	IOR..500..MT	IOR..400..MT	IOR..800	IOR..1400	
1000	IOR..2100	IOR..1700	IOR..1400..MT	IOR..800	IOR..500..MT	IOR..400..MT	IOR..800	IOR..1400	



Notes

Handwriting practice area consisting of multiple horizontal dotted lines.



Alternator field discharge

AM-CC-NOR, AM-CC-JORE and AMF-CC-JORE contactors

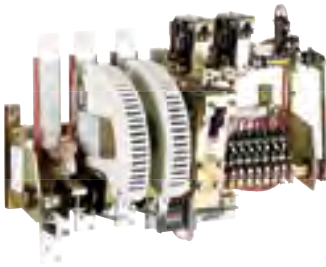

AMF-CC-JORE 800-21

Application

Alternator field discharge (or field circuit breakers) are used to control the field winding of synchronous machines or exciter machines. In case of disturbances, the contactors ensure a definite disconnection from the supply source and the subsequent discharge of the energy stored in the machine magnetic circuit via a discharge resistor.

Diagram

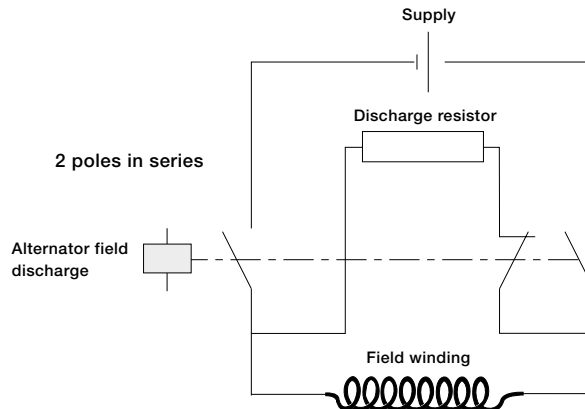

Description

These contactors are designed with:

- 2 or 3 N.O. main poles with blowout devices, suitable for 2250 V DC max. operational voltage and circuit time constant $L/R \leq 15$ ms
- 1 N.C. main pole, without blowout device, named "discharge pole" and set MAKE before BREAK with regard to the N.O. main poles. For N.C. main pole with breaking capacity, please consult us.

Electro-magnet

AM-CC-JOR and **AMF-CC-JOR** alternator field discharge are equipped with a latching device:

- magnetical latch for R63 ... R200
- mechanical latch for R550 ... R4500.

AC or DC control circuit.

The **AMF-CC-JOR** type is equipped with 2 tripping coils (double de-latching control).

Auxiliary contacts

- AM-CC: 5 auxiliary contacts as standard (3 N.O. + 2 N.C.)
- AMF-CC: 4 auxiliary contacts as standard (2 N.O. + 2 N.C.)
- Up to 16 auxiliary contacts max. on request.



AM-CC alternator field discharge contactors

For DC circuit switching



Magnetical latch

Contactor type	Single tripping coil		AM-CC-NOR63	AM-CC-NOR125	AM-CC-NOR200
	Double tripping coil		-	-	-
	U _e (L/R ≤ 5 ms)				
2-pole in series					
Rated operational current	θ ≤ 40 °C	600 V DC	85 A	150 A	250 A
		1500 V DC max.			
3-pole in series					
Rated operational current	θ ≤ 40 °C	1000 V DC	85 A	150 A	250 A
		2250 V DC max.			

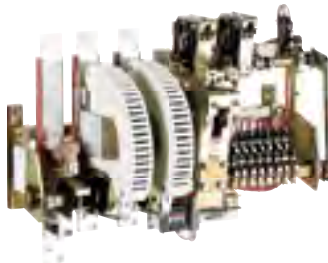

Mechanical latch

Contactor type	Single tripping coil		AM-CC-JORE550	AM-CC-JORE800	AM-CC-JORE1000	AM-CC-JORE1400
	Double tripping coil		AMF-CC-JORE550	AMF-CC-JORE800	AMF-CC-JORE1000	AMF-CC-JORE1400
	U _e (L/R ≤ 15 ms)					
2-pole in series						
Rated operational current	θ ≤ 40 °C	750 V DC	550 A	800 A	1000 A	1300 A
		1500 V DC max.				
3-pole in series						
Rated operational current	θ ≤ 40 °C	1000 V DC	550 A	800 A	1000 A	1300 A
		2250 V DC max.				

AM-CC alternator field discharge contactors

For DC circuit switching



AM-CC-JORE1700	AM-CC-JORE2100	AM-CC-JORE2500	AM-CC-JORE3200	AM-CC-JORE3800	AM-CC-JORE4500
AMF-CC-JORE1700	AMF-CC-JORE2100	AMF-CC-JORE2500	AMF-CC-JORE3200	AMF-CC-JORE3800	AMF-CC-JORE4500
1600 A	2000 A	2300 A	3200 A	3800 A	4500 A
1600 A	2000 A	2300 A	3200 A	3800 A	-

AM-CC-NOR63 alternator field discharge contactors

Technical data

N.O. main pole - Utilization characteristics

Types	Single tripping coil	AM-CC-NOR63-21	AM-CC-NOR63-31
Number of N.O. poles in series		2	3
Rated operational voltage Ue		600 V DC	1000 V DC
Maximum breaking voltage		1500 V DC	2250 V DC
Conventional free-air thermal current Ith			
Open contactors	$\theta \leq 40\text{ °C}$	85 A	
With conductor cross-sectional area		25 mm ²	
Ie / Rated operational current			
	$\theta \leq 40\text{ °C}$	85 A	
	$\theta \leq 50\text{ °C}$	75 A	
Rated short-time withstand current Icw at 40 °C ambient temperature, in free air from a cold state			
	1 s	1150 A	
	10 s	680 A	
	30 s	310 A	
	1 min	230 A	
	15 min	120 A	
Maximum breaking capacity at Ue (L / R \leq 5 ms)			
	500 V	1200 A	1200 A
	600 V	1200 A	1200 A
	900 V	1000 A	-
	1 000 V	-	1200 A
	1 500 V	800 A	1000 A
	2 250 V	-	800 A
Maximum making capacity		1300 A	
Dynamical withstand of pole		1400 A	
Impedance per pole		1.80 m Ω	

N.C. de-energisation pole - Utilization characteristics

Types	Single tripping coil	AM-CC-NOR63-21	AM-CC-NOR63-31
Number of N.C. de-energisation pole		1	
Conventional free-air thermal current Ith			
Open contactors	$\theta \leq 40\text{ °C}$	85 A	
With conductor cross-sectional area		25 mm ²	
Maximum making capacity		500 A	
Rated short time current			
	0.5 s	1000 A	
	15 s	250 A	
Maximum breaking capacity at Ue		No breaking capacity	
Impedance per pole		1.80 m Ω	

General technical data

Types	Single tripping coil	AM-CC-NOR63-21	AM-CC-NOR63-31
Rated impulse withstand voltage Uimp.		8 kV	
Dielectric test voltage / 1 min		5500 V AC 50 Hz	6000 V AC 50 Hz
Ambient air temperature close to contactor			
Operation in free air		-20...+55 °C	
Storage		-20...+80 °C	
Climatic withstand		Standard version for industrial environment and atmospheres	
Maximum operating altitude (without derating)		2000 m	
Mechanical durability			
Number of operating cycles		200000 cycles	

Construction characteristics

Types	Single tripping coil	AM-CC-NOR63-21	AM-CC-NOR63-31
Standard combination of auxiliary contacts		3 N.O. + 2 N.C.:	
		1 CARB (N.O.) + 1 CA12-1 (N.O. + N.C.) + 1 CA15-F (N.O.) + 1 CA15-O (N.C.)	
Maximum number of auxiliary contacts		6	5
Fixing dimensions (F)			
Width		345 mm	445 mm
Weight		368 mm	468 mm
Weight		4.1 kg	5 kg

AM-CC-NOR63 alternator field discharge contactors

Technical data



Magnet system characteristics

Types	Single tripping coil	AM-CC-NOR63-21	AM-CC-NOR63-31
Coil operating limits			
acc. to IEC 60947-4-1		At $\theta \leq 55^\circ\text{C}$ 0.85...1.1 x U _c	
DC control voltage			
Rated control circuit voltage U _c		24...220 V DC	
Coil consumption		Average pull-in value	250 W
		Tripping	150 W
Operating time (average values for U_c)			
Closing time		30 ms	
Opening time		20 ms	

Mounting characteristics

Types	Single tripping coil	AM-CC-NOR63-21	AM-CC-NOR63-31
Fixing by screws (not supplied)			
		2 x M6	2 x M6

Connecting characteristics

Types	Single tripping coil	AM-CC-NOR63-21	AM-CC-NOR63-31
Connection capacity (min. ... max.)			
Main conductors (poles)			
Terminal plates width		16 mm	
Terminal screw (not supplied)		M6 x 20	
Drilling holes (without thread)		-	
Auxiliary conductors			
(built-in auxiliary terminals + coil terminals)			
	Rigid solid	1 or 2 x	1...2.5 mm ²
	Flexible with non insulated ferrule	1 or 2 x	1...2.5 mm ²
Tightening torque			
Coil terminals		1.5 Nm	
Built-in auxiliary terminals		1.5 Nm	
Screw terminals			
Main terminals		Screws and bolts	
Coil terminals		M4 with cable clamps	
Built-in auxiliary terminals		M4 with cable clamps	



AM-CC-NOR125 alternator field discharge contactors

Technical data

N.O. main pole - Utilization characteristics

Types	Single tripping coil	AM-CC-NOR125-21	AM-CC-NOR125-31
Number of N.O. poles in series		2	3
Rated operational voltage Ue		600 V DC	1000 V DC
Maximum breaking voltage		1500 V DC	2250 V DC
Conventional free-air thermal current Ith			
Open contactors	$\theta \leq 40\text{ °C}$	150 A	
With conductor cross-sectional area		50 mm ²	
Ie / Rated operational current			
	$\theta \leq 40\text{ °C}$	150 A	
	$\theta \leq 50\text{ °C}$	135 A	
Rated short-time withstand current Icw			
at 40 °C ambient temperature,	1 s	2250 A	
in free air from a cold state	10 s	1280 A	
	30 s	680 A	
	1 min	450 A	
	15 min	250 A	
Maximum breaking capacity at Ue			
(L / R ≤ 5 ms)	500 V	2000 A	2000 A
	600 V	2000 A	2000 A
	900 V	1600 A	-
	1 000 V	-	2000 A
	1 500 V	1400 A	1600 A
	2 250 V	-	1400 A
Maximum making capacity		2400 A	
Dynamical withstand of pole		2500 A	
Impedance per pole		1.20 mΩ	

N.C. de-energisation pole - Utilization characteristics

Types	Single tripping coil	AM-CC-NOR125-21	AM-CC-NOR125-31
Number of N.C. de-energisation pole		1	
Conventional free-air thermal current Ith			
Open contactors	$\theta \leq 40\text{ °C}$	125 A	
With conductor cross-sectional area		50 mm ²	
Maximum making capacity		1000 A	
Rated short time current			
	0.5 s	1700 A	
	15 s	450 A	
Maximum breaking capacity at Ue		No breaking capacity	
Impedance per pole		1.20 mΩ	

General technical data

Types	Single tripping coil	AM-CC-NOR125-21	AM-CC-NOR125-31
Rated impulse withstand voltage Uimp.		8 kV	
Dielectric test voltage / 1 min		5500 V AC 50 Hz	6000 V AC 50 Hz
Ambient air temperature close to contactor			
Operation in free air		-20...+55 °C	
Storage		-20...+80 °C	
Climatic withstand		Standard version for industrial environment and atmospheres	
Maximum operating altitude (without derating)		2000 m	
Mechanical durability			
Number of operating cycles		200000 cycles	

Construction characteristics

Types	Single tripping coil	AM-CC-NOR125-21	AM-CC-NOR125-31
Standard combination of auxiliary contacts		3 N.O. + 2 N.C.:	
		1 CARB (N.O.) + 1 CA12-1 (N.O. + N.C.) + 1 CA15-F (N.O.) + 1 CA15-O (N.C.)	
Maximum number of auxiliary contacts		5	12
Fixing dimensions (F)		385 mm	445 mm
Width		414 mm	474 mm
Weight		4.1 kg	4.9 kg
			5 kg

AM-CC-NOR125 alternator field discharge contactors

Technical data



Magnet system characteristics

Types	Single tripping coil	AM-CC-NOR125-21	AM-CC-NOR125-31
Coil operating limits acc. to IEC 60947-4-1			
		At $\theta \leq 55^\circ\text{C}$ 0.85...1.1 x U _c	
DC control voltage			
Rated control circuit voltage U _c		24...220 V DC	
Coil consumption		Average pull-in value	250 W
		Tripping	150 W
Operating time (average values for U_c)			
Closing time		30 ms	
Opening time		20 ms	

Mounting characteristics

Types	Single tripping coil	AM-CC-NOR125-21	AM-CC-NOR125-31
Fixing by screws (not supplied)			
		2 x M6	2 x M6

Connecting characteristics

Types	Single tripping coil	AM-CC-NOR125-21	AM-CC-NOR125-31
Connection capacity (min. ... max.)			
Main conductors (poles)			
Terminal plates width		20 mm	
Terminal screw (not supplied)		M8 x 20	
Drilling holes (without thread)		-	
Auxiliary conductors (built-in auxiliary terminals + coil terminals)			
	Rigid solid	1 or 2 x	1...2.5 mm ²
	Flexible with non insulated ferrule	1 or 2 x	1...2.5 mm ²
Tightening torque			
Coil terminals		1.5 Nm	
Built-in auxiliary terminals		1.5 Nm	
Screw terminals			
Main terminals		Screws and bolts	
Coil terminals		M4 with cable clamps	
Built-in auxiliary terminals		M4 with cable clamps	



AM-CC-NOR200 alternator field discharge contactors

Technical data

N.O. main pole - Utilization characteristics

Types	Single tripping coil	AM-CC-NOR200-21	AM-CC-NOR200-31
Number of N.O. poles in series		2	3
Rated operational voltage U _e		600 V DC	1000 V DC
Maximum breaking voltage		1500 V DC	2250 V DC
Conventional free-air thermal current I _{th}			
Open contactors	θ ≤ 40 °C	250 A	
With conductor cross-sectional area		150 mm ²	
I _e / Rated operational current			
	θ ≤ 40 °C	250 A	
	θ ≤ 50 °C	225 A	
Rated short-time withstand current I _{cw} at 40 °C ambient temperature, in free air from a cold state			
	1 s	3800 A	
	10 s	2080 A	
	30 s	1040 A	
	1 min	730 A	
	15 min	390 A	
Maximum breaking capacity at U _e (L / R ≤ 5 ms)			
	500 V	3500 A	3500 A
	600 V	3500 A	3500 A
	900 V	2600 A	-
	1 000 V	-	3500 A
	1 500 V	2000 A	2600 A
	2 250 V	-	2000 A
Maximum making capacity		4000 A	
Dynamical withstand of pole		4500 A	
Impedance per pole		0.6 mΩ	

N.C. de-energisation pole - Utilization characteristics

Types	Single tripping coil	AM-CC-NOR200-21	AM-CC-NOR200-31
Number of N.C. de-energisation pole		1	
Conventional free-air thermal current I _{th}			
Open contactors	θ ≤ 40 °C	200 A	
With conductor cross-sectional area		95 mm ²	
Maximum making capacity		1200 A	
Rated short time current			
	0.5 s	2500 A	
	15 s	600 A	
Maximum breaking capacity at U _e		No breaking capacity	
Impedance per pole		0.6 mΩ	

General technical data

Types	Single tripping coil	AM-CC-NOR200-21	AM-CC-NOR200-31
Rated impulse withstand voltage U _{imp}		8 kV	
Dielectric test voltage / 1 min		5500 V AC 50 Hz	6000 V AC 50 Hz
Ambient air temperature close to contactor			
Operation in free air		-20...+55 °C	
Storage		-20...+80 °C	
Climatic withstand		Standard version for industrial environment and atmospheres	
Maximum operating altitude (without derating)		2000 m	
Mechanical durability			
Number of operating cycles		200000 cycles	

Construction characteristics

Types	Single tripping coil	AM-CC-NOR200-21	AM-CC-NOR200-31
Standard combination of auxiliary contacts		3 N.O. + 2 N.C.:	
		1 CARB (N.O.) + 1 CA12-1 (N.O. + N.C.) + 1 CA15-F (N.O.) + 1 CA15-O (N.C.)	
Maximum number of auxiliary contacts		5	5
Fixing dimensions (F)			
Width		445 mm	540 mm
		464 mm	559 mm
Weight		10.5 kg	12.5 kg

AM-CC-NOR200 alternator field discharge contactors

Technical data



Magnet system characteristics

Types	Single tripping coil	AM-CC-NOR200-21	AM-CC-NOR200-31
Coil operating limits			
acc. to IEC 60947-4-1		At $\theta \leq 55^\circ\text{C}$ 0.85...1.1 x U _c	
DC control voltage			
Rated control circuit voltage U _c		24...220 V DC	
Coil consumption		Average pull-in value	500 W
		Tripping	250 W
Operating time (average values for U_c)			
Closing time		40 ms	
Opening time		20 ms	

Mounting characteristics

Types	Single tripping coil	AM-CC-NOR200-21	AM-CC-NOR200-31
Fixing by screws (not supplied)			
		2 x M8	2 x M8

Connecting characteristics

Types	Single tripping coil	AM-CC-NOR200-21	AM-CC-NOR200-31
Connection capacity (min. ... max.)			
Main conductors (poles)			
Terminal plates width		25 mm	
Terminal screw (not supplied)		M10 x 25	
Drilling holes (without thread)		-	
Auxiliary conductors			
(built-in auxiliary terminals + coil terminals)			
	Rigid solid	1 or 2 x	1...2.5 mm ²
	Flexible with non insulated ferrule	1 or 2 x	1...2.5 mm ²
Tightening torque			
Coil terminals		1.5 Nm	
Built-in auxiliary terminals		1.5 Nm	
Screw terminals			
Main terminals		Screws and bolts	
Coil terminals		M4 with cable clamps	
Built-in auxiliary terminals		M4 with cable clamps	



AM-CC-JORE550 and AMF-CC-JORE550 alternator field discharge contactors

Technical data

N.O. main pole - Utilization characteristics

Types	Single tripping coil	AM-CC-JORE550-21		AM-CC-JORE550-31	
	Double tripping coil	AMF-CC-JORE550-21		AMF-CC-JORE550-31	
Number of N.O. poles in series		2		3	
Rated operational voltage Ue		750 V DC		1000 V DC	
Maximum breaking voltage		1500 V DC		2250 V DC	
Conventional free-air thermal current Ith		550 A		550 A	
Open contactors	$\theta \leq 40\text{ }^{\circ}\text{C}$	400 mm ²		400 mm ²	
With conductor cross-sectional area		550 A		550 A	
le / Rated operational current	$\theta \leq 40\text{ }^{\circ}\text{C}$	500 A		500 A	
	$\theta \leq 50\text{ }^{\circ}\text{C}$	8400 A		8400 A	
Rated short-time withstand current Icw	1 s	4400 A		4400 A	
at 40 °C ambient temperature,	10 s	2200 A		2200 A	
in free air from a cold state	30 s	1680 A		1680 A	
	1 min	840 A		840 A	
	15 min	7000 A		7000 A	
Maximum breaking capacity at Ue	550 V	7000 A		7000 A	
(L / R ≤ 15 ms)	750 V	7000 A		7000 A	
	1000 V	6500 A		7000 A	
	1500 V	5000 A		6500 A	
	2250 V	-		5000 A	
Maximum making capacity		9000 A		9000 A	
Dynamical withstand of pole		10000 A		10000 A	
Impedance per pole		0.35 mΩ		0.35 mΩ	

N.C. de-energisation pole - Utilization characteristics

Types	Single tripping coil	AM-CC-JORE550-21		AM-CC-JORE550-31	
	Double tripping coil	AMF-CC-JORE550-21		AMF-CC-JORE550-31	
Number of N.C. de-energisation pole		1		1	
Conventional free-air thermal current Ith		550 A		550 A	
Open contactors	$\theta \leq 40\text{ }^{\circ}\text{C}$	400 mm ²		400 mm ²	
With conductor cross-sectional area		7000 A		7000 A	
Maximum making capacity		8400 A		8400 A	
Rated short time current	0.5 s	3500 A		3500 A	
	15 s	No breaking capacity		No breaking capacity	
Maximum breaking capacity at Ue		0.35 mΩ		0.35 mΩ	
Impedance per pole					

General technical data

Types	Single tripping coil	AM-CC-JORE550-21		AM-CC-JORE550-31	
	Double tripping coil	AMF-CC-JORE550-21		AMF-CC-JORE550-31	
Rated impulse withstand voltage Uimp.		8 kV		8 kV	
Dielectric test voltage / 1 min		5500 V AC 50 Hz		6000 V AC 50 Hz	
Ambient air temperature close to contactor		-20...+55 °C		-20...+55 °C	
Operation in free air		-20...+80 °C		-20...+80 °C	
Storage		Standard version for industrial environment and atmospheres		Standard version for industrial environment and atmospheres	
Climatic withstand		2000 m		2000 m	
Maximum operating altitude (without derating)		200000 cycles		200000 cycles	
Mechanical durability					
Number of operating cycles					

Construction characteristics

Types	Single tripping coil	AM-CC-JORE550-21		AM-CC-JORE550-31	
	Double tripping coil	AMF-CC-JORE550-21		AMF-CC-JORE550-31	
Standard combination of auxiliary contacts		3 N.O. + 2 N.C.:		2 N.O. + 2 N.C.:	
		3 CA15-F (N.O.)		3 N.O. + 2 N.C.:	
		+ 2 CA15-O (N.C.)		3 CA15-F (N.O.)	
				+ 2 CA15-O (N.C.)	
Maximum number of auxiliary contacts		5	12	5	12
Fixing dimensions (F)		635 mm	760 mm	635 mm	760 mm
Width		664 mm	789 mm	664 mm	789 mm
Weight		30 kg	32 kg	31 kg	33 kg

AM-CC-JORE550 and AMF-CC-JORE550 alternator field discharge contactors

Technical data



Magnet system characteristics

Types	Single tripping coil	AM-CC-JORE550-21	AM-CC-JORE550-31
	Double tripping coil	AMF-CC-JORE550-21	AMF-CC-JORE550-31
Coil operating limits acc. to IEC 60947-4-1		At $\theta \leq 55^\circ\text{C}$ 0.85...1.1 x U _c	
DC control voltage		24...220 V DC	
Rated control circuit voltage U _c Coil consumption	Average pull-in value	550 W	550 W
	Tripping	110 W	110 W
Operating time (average values for U_c)			
Closing time		60 ms	
Opening time		40 ms	

Mounting characteristics

Types	Single tripping coil	AM-CC-JORE550-21	AM-CC-JORE550-31
	Double tripping coil	AMF-CC-JORE550-21	AMF-CC-JORE550-31
Fixing by screws (not supplied)		2 x M12	2 x M12

Connecting characteristics

Types	Single tripping coil	AM-CC-JORE550-21	AM-CC-JORE550-31
	Double tripping coil	AMF-CC-JORE550-21	AMF-CC-JORE550-31
Connection capacity (min. ... max.)			
Main conductors (poles)			
Terminal plates width		30 mm	
Terminal screw (not supplied)		-	
Drilling holes (without thread)		1 x \varnothing 13 mm	
Auxiliary conductors (built-in auxiliary terminals + coil terminals)			
 Rigid solid	1 or 2 x	1...2.5 mm ²	
 Flexible with non insulated ferrule	1 or 2 x	1...2.5 mm ²	
Tightening torque			
Coil terminals		1.5 Nm	
Built-in auxiliary terminals		1.5 Nm	
Screw terminals			
Main terminals		Screws and bolts	
Coil terminals		M4 with cable clamps	
Built-in auxiliary terminals		M4 with cable clamps	



AM-CC-JORE800 and AMF-CC-JORE800 alternator field discharge contactors

Technical data

N.O. main pole - Utilization characteristics

Types	Single tripping coil	AM-CC-JORE800-21	AM-CC-JORE800-31
	Double tripping coil	AMF-CC-JORE800-21	AMF-CC-JORE800-31
Number of N.O. poles in series		2	3
Rated operational voltage U _e		750 V DC	1000 V DC
Maximum breaking voltage		1500 V DC	2250 V DC
Conventional free-air thermal current I _{th}			
Open contactors	θ ≤ 40 °C	800 A	
With conductor cross-sectional area		500 mm ²	
I _e / Rated operational current	θ ≤ 40 °C	800 A	
	θ ≤ 50 °C	700 A	
Rated short-time withstand current I _{cw} at 40 °C ambient temperature, in free air from a cold state	1 s	9000 A	
	10 s	6400 A	
	30 s	3200 A	
	1 min	2100 A	
	15 min	1200 A	
Maximum breaking capacity at U _e (L / R ≤ 15 ms)	550 V	22000 A	22000 A
	750 V	16000 A	20000 A
	1000 V	11000 A	17000 A
	1500 V	8000 A	10000 A
	2250 V	-	7000 A
Maximum making capacity		14000 A	
Dynamical withstand of pole		14000 A	
Impedance per pole		0.28 mΩ	

N.C. de-energisation pole - Utilization characteristics

Types	Single tripping coil	AM-CC-JORE800-21	AM-CC-JORE800-31
	Double tripping coil	AMF-CC-JORE800-21	AMF-CC-JORE800-31
Number of N.C. de-energisation pole		1	
Conventional free-air thermal current I _{th}			
Open contactors	θ ≤ 40 °C	1000 A	
With conductor cross-sectional area		500 mm ²	
Maximum making capacity		9000 A	
Rated short time current	0.5 s	10000 A	
	15 s	6000 A	
Maximum breaking capacity at U _e		No breaking capacity	
Impedance per pole		0.18 mΩ	

General technical data

Types	Single tripping coil	AM-CC-JORE800-21	AM-CC-JORE800-31
	Double tripping coil	AMF-CC-JORE800-21	AMF-CC-JORE800-31
Rated impulse withstand voltage U _{imp}		8 kV	
Dielectric test voltage / 1 min		5500 V AC 50 Hz	6000 V AC 50 Hz
Ambient air temperature close to contactor			
Operation in free air		-20...+55 °C	
Storage		-20...+80 °C	
Climatic withstand		Standard version for industrial environment and atmospheres	
Maximum operating altitude (without derating)		2000 m	
Mechanical durability			
Number of operating cycles		200000 cycles	

Construction characteristics

Types	Single tripping coil	AM-CC-JORE800-21	AM-CC-JORE800-31
	Double tripping coil	AMF-CC-JORE800-21	AMF-CC-JORE800-31
Standard combination of auxiliary contacts		3 N.O. + 2 N.C.: 3 CA15-F (N.O.) + 2 CA15-O (N.C.)	2 N.O. + 2 N.C.: 2 CA15-F (N.O.) + 2 CA15-O (N.C.)
Maximum number of auxiliary contacts		5	5
Fixing dimensions (F)		20	20
Width		16	16
Weight		540 mm 570 mm 570 mm	540 mm 640 mm 640 mm
		630 mm 660 mm 660 mm	630 mm 730 mm 730 mm
		58 kg 58 kg 59 kg	70 kg 70 kg 71 kg

AM-CC-JORE800 and AMF-CC-JORE800 alternator field discharge contactors

Technical data



Magnet system characteristics

Types	Single tripping coil	AM-CC-JORE800-21	AM-CC-JORE800-31
	Double tripping coil	AMF-CC-JORE800-21	AMF-CC-JORE800-31
Coil operating limits acc. to IEC 60947-4-1	At $\theta \leq 55^\circ\text{C}$ 0.85...1.1 x U _c		
DC control voltage	24...220 V DC		
Rated control circuit voltage U _c	Average pull-in value	650 W	650 W
Coil consumption	Tripping	265 W	265 W
Operating time (average values for U_c)			
Closing time	100 ms		
Opening time	55 ms		

Mounting characteristics

Types	Single tripping coil	AM-CC-JORE800-21	AM-CC-JORE800-31
	Double tripping coil	AMF-CC-JORE800-21	AMF-CC-JORE800-31
Fixing by screws (not supplied)	4 x M12		4 x M12

Connecting characteristics

Types	Single tripping coil	AM-CC-JORE800-21	AM-CC-JORE800-31
	Double tripping coil	AMF-CC-JORE800-21	AMF-CC-JORE800-31
Connection capacity (min. ... max.)			
Main conductors (poles)			
Terminal plates width	48 mm		
Terminal screw (not supplied)	-		
Drilling holes (without thread)	2 x \varnothing 13 mm		
Auxiliary conductors (built-in auxiliary terminals + coil terminals)			
 Rigid solid	1 or 2 x	1...2.5 mm ²	
 Flexible with non insulated ferrule	1 or 2 x	1...2.5 mm ²	
Tightening torque			
Coil terminals	1.5 Nm		
Built-in auxiliary terminals	1.5 Nm		
Screw terminals			
Main terminals	Screws and bolts		
Coil terminals	M4 with cable clamps		
Built-in auxiliary terminals	M4 with cable clamps		



AM-CC-JORE1000 and AMF-CC-JORE1000 alternator field discharge contactors

Technical data

N.O. main pole - Utilization characteristics

Types	Single tripping coil	AM-CC-JORE1000-21		AM-CC-JORE1000-31	
	Double tripping coil	AMF-CC-JORE1000-21		AMF-CC-JORE1000-31	
Number of N.O. poles in series		2		3	
Rated operational voltage U _e		750 V DC		1000 V DC	
Maximum breaking voltage		1500 V DC		2250 V DC	
Conventional free-air thermal current I _{th}					
Open contactors	θ ≤ 40 °C	1000 A			
With conductor cross-sectional area		600 mm ²			
I _e / Rated operational current	θ ≤ 40 °C	1000 A			
	θ ≤ 50 °C	850 A			
Rated short-time withstand current I _{cw} at 40 °C ambient temperature, in free air from a cold state	1 s	9000 A			
	10 s	6400 A			
	30 s	3200 A			
	1 min	2100 A			
	15 min	1200 A			
Maximum breaking capacity at U _e (L / R ≤ 15 ms)	550 V	22000 A		22000 A	
	750 V	16000 A		20000 A	
	1000 V	11000 A		17000 A	
	1 500 V	8000 A		10000 A	
	2 250 V	-		7000 A	
Maximum making capacity		14000 A			
Dynamical withstand of pole		14000 A			
Impedance per pole		0.24 mΩ			

N.C. de-energisation pole - Utilization characteristics

Types	Single tripping coil	AM-CC-JORE1000-21		AM-CC-JORE1000-31	
	Double tripping coil	AMF-CC-JORE1000-21		AMF-CC-JORE1000-31	
Number of N.C. de-energisation pole		1			
Conventional free-air thermal current I _{th}					
Open contactors	θ ≤ 40 °C	1000 A			
With conductor cross-sectional area		500 mm ²			
Maximum making capacity		9000 A			
Rated short time current	0.5 s	10000 A			
	15 s	6000 A			
Maximum breaking capacity at U _e		No breaking capacity			
Impedance per pole		0.18 mΩ			

General technical data

Types	Single tripping coil	AM-CC-JORE1000-21		AM-CC-JORE1000-31	
	Double tripping coil	AMF-CC-JORE1000-21		AMF-CC-JORE1000-31	
Rated impulse withstand voltage U _{imp}		8 kV			
Dielectric test voltage / 1 min		5500 V AC 50 Hz		6000 V AC 50 Hz	
Ambient air temperature close to contactor					
Operation in free air		-20...+55 °C			
Storage		-20...+80 °C			
Climatic withstand		Standard version for industrial environment and atmospheres			
Maximum operating altitude (without derating)		2000 m			
Mechanical durability					
Number of operating cycles		200000 cycles			

Construction characteristics

Types	Single tripping coil	AM-CC-JORE1000-21		AM-CC-JORE1000-31	
	Double tripping coil	AMF-CC-JORE1000-21		AMF-CC-JORE1000-31	
Standard combination of auxiliary contacts		3 N.O. + 2 N.C.:		3 N.O. + 2 N.C.:	
		3 CA15-F (N.O.)		3 CA15-F (N.O.)	
		+ 2 CA15-O (N.C.)		+ 2 CA15-O (N.C.)	
Maximum number of auxiliary contacts	5	20	16	5	20
Fixing dimensions (F)	550 mm	650 mm	650 mm	650 mm	760 mm
Width	640 mm	740 mm	740 mm	740 mm	850 mm
Weight	59 kg	59 kg	60 kg	71 kg	72 kg

AM-CC-JORE1000 and AMF-CC-JORE1000 alternator field discharge contactors

Technical data



Magnet system characteristics

Types	Single tripping coil	AM-CC-JORE1000-21	AM-CC-JORE1000-31
	Double tripping coil	AMF-CC-JORE1000-21	AMF-CC-JORE1000-31
Coil operating limits acc. to IEC 60947-4-1		At $\theta \leq 55^\circ\text{C}$ 0.85...1.1 x U_c	
DC control voltage		24...220 V DC	
Rated control circuit voltage U_c Coil consumption	Average pull-in value	650 W	650 W
	Tripping	265 W	265 W
Operating time (average values for U_c)			
Closing time		100 ms	
Opening time		55 ms	

Mounting characteristics

Types	Single tripping coil	AM-CC-JORE1000-21	AM-CC-JORE1000-31
	Double tripping coil	AMF-CC-JORE1000-21	AMF-CC-JORE1000-31
Fixing by screws (not supplied)		4 x M12	4 x M12

Connecting characteristics

Types	Single tripping coil	AM-CC-JORE1000-21	AM-CC-JORE1000-31
	Double tripping coil	AMF-CC-JORE1000-21	AMF-CC-JORE1000-31
Connection capacity (min. ... max.)			
Main conductors (poles)			
Terminal plates width		48 mm	
Terminal screw (not supplied)		-	
Drilling holes (without thread)		2 x $\varnothing 13$ mm	
Auxiliary conductors (built-in auxiliary terminals + coil terminals)			
	Rigid solid	1 or 2 x	1...2.5 mm ²
	Flexible with non insulated ferrule	1 or 2 x	1...2.5 mm ²
Tightening torque			
Coil terminals		1.5 Nm	
Built-in auxiliary terminals		1.5 Nm	
Screw terminals			
Main terminals		Screws and bolts	
Coil terminals		M4 with cable clamps	
Built-in auxiliary terminals		M4 with cable clamps	



AM-CC-JORE1400 and AMF-CC-JORE1400 alternator field discharge contactors

Technical data

N.O. main pole - Utilization characteristics

Types	Single tripping coil	AM-CC-JORE1400-21		AM-CC-JORE1400-31	
	Double tripping coil	AMF-CC-JORE1400-21		AMF-CC-JORE1400-31	
Number of N.O. poles in series		2		3	
Rated operational voltage Ue		750 V DC		1000 V DC	
Maximum breaking voltage		1500 V DC		2250 V DC	
Conventional free-air thermal current Ith					
Open contactors	$\theta \leq 40\text{ }^{\circ}\text{C}$	1300 A			
With conductor cross-sectional area		800 mm ²			
Ie / Rated operational current	$\theta \leq 40\text{ }^{\circ}\text{C}$	1300 A			
	$\theta \leq 50\text{ }^{\circ}\text{C}$	1200 A			
Rated short-time withstand current Icw	1 s	11000 A			
at 40 °C ambient temperature,	10 s	9000 A			
in free air from a cold state	30 s	5000 A			
	1 min	3600 A			
	15 min	1900 A			
Maximum breaking capacity at Ue	550 V	22000 A		22000 A	
(L / R ≤ 15 ms)	750 V	16000 A		20000 A	
	1000 V	11000 A		17000 A	
	1500 V	8000 A		10000 A	
	2250 V	-		7000 A	
Maximum making capacity		19000 A			
Dynamical withstand of pole		19000 A			
Impedance per pole		0.18 mΩ			

N.C. de-energisation pole - Utilization characteristics

Types	Single tripping coil	AM-CC-JORE1400-21		AM-CC-JORE1400-31	
	Double tripping coil	AMF-CC-JORE1400-21		AMF-CC-JORE1400-31	
Number of N.C. de-energisation pole		1			
Conventional free-air thermal current Ith					
Open contactors	$\theta \leq 40\text{ }^{\circ}\text{C}$	1000 A			
With conductor cross-sectional area		500 mm ²			
Maximum making capacity		9000 A			
Rated short time current	0.5 s	10000 A			
	15 s	6000 A			
Maximum breaking capacity at Ue		No breaking capacity			
Impedance per pole		0.18 mΩ			

General technical data

Types	Single tripping coil	AM-CC-JORE1400-21		AM-CC-JORE1400-31	
	Double tripping coil	AMF-CC-JORE1400-21		AMF-CC-JORE1400-31	
Rated impulse withstand voltage Uimp.		8 kV			
Dielectric test voltage / 1 min		5500 V AC 50 Hz		6000 V AC 50 Hz	
Ambient air temperature close to contactor					
Operation in free air		-20...+55 °C			
Storage		-20...+80 °C			
Climatic withstand		Standard version for industrial environment and atmospheres			
Maximum operating altitude (without derating)		2000 m			
Mechanical durability					
Number of operating cycles		200000 cycles			

Construction characteristics

Types	Single tripping coil	AM-CC-JORE1400-21		AM-CC-JORE1400-31	
	Double tripping coil	AMF-CC-JORE1400-21		AMF-CC-JORE1400-31	
Standard combination of auxiliary contacts		3 N.O. + 2 N.C.:		3 N.O. + 2 N.C.:	
		3 CA15-F (N.O.)		3 CA15-F (N.O.)	
		+ 2 CA15-O (N.C.)		+ 2 CA15-O (N.C.)	
Maximum number of auxiliary contacts	5	20	16	5	20
Fixing dimensions (F)	550 mm	650 mm	650 mm	650 mm	760 mm
Width	640 mm	740 mm	740 mm	740 mm	850 mm
Weight	60 kg	60 kg	61 kg	72 kg	73 kg

AM-CC-JORE1400 and AMF-CC-JORE1400 alternator field discharge contactors

Technical data



Magnet system characteristics

Types	Single tripping coil	AM-CC-JORE1400-21	AM-CC-JORE1400-31
	Double tripping coil	AMF-CC-JORE1400-21	AMF-CC-JORE1400-31
Coil operating limits acc. to IEC 60947-4-1		At $\theta \leq 55^\circ\text{C}$ 0.85...1.1 x U _c	
DC control voltage		24...220 V DC	
Rated control circuit voltage U _c Coil consumption	Average pull-in value	650 W	950 W
	Tripping	265 W	265 W
Operating time (average values for U_c)			
Closing time		100 ms	
Opening time		50 ms	

Mounting characteristics

Types	Single tripping coil	AM-CC-JORE1400-21	AM-CC-JORE1400-31
	Double tripping coil	AMF-CC-JORE1400-21	AMF-CC-JORE1400-31
Fixing by screws (not supplied)		4 x M12	4 x M12

Connecting characteristics

Types	Single tripping coil	AM-CC-JORE1400-21	AM-CC-JORE1400-31
	Double tripping coil	AMF-CC-JORE1400-21	AMF-CC-JORE1400-31
Connection capacity (min. ... max.)			
Main conductors (poles)			
Terminal plates width		60 mm	
Terminal screw (not supplied)		-	
Drilling holes (without thread)		2 x \varnothing 13 mm	
Auxiliary conductors (built-in auxiliary terminals + coil terminals)			
 Rigid solid	1 or 2 x	1...2.5 mm ²	
 Flexible with non insulated ferrule	1 or 2 x	1...2.5 mm ²	
Tightening torque			
Coil terminals		1.5 Nm	
Built-in auxiliary terminals		1.5 Nm	
Screw terminals			
Main terminals		Screws and bolts	
Coil terminals		M4 with cable clamps	
Built-in auxiliary terminals		M4 with cable clamps	



AM-CC-JORE1700 and AMF-CC-JORE1700 alternator field discharge contactors

Technical data

N.O. main pole - Utilization characteristics

Types	Single tripping coil	AM-CC-JORE1700-21	AM-CC-JORE1700-31
	Double tripping coil	AMF-CC-JORE1700-21	AMF-CC-JORE1700-31
Number of N.O. poles in series		2	3
Rated operational voltage U _e		750 V DC	1000 V DC
Maximum breaking voltage		1500 V DC	2250 V DC
Conventional free-air thermal current I _{th}			
Open contactors	θ ≤ 40 °C	1600 A	
With conductor cross-sectional area		1000 mm ²	
I _e / Rated operational current	θ ≤ 40 °C	1 600 A	
	θ ≤ 50 °C	1 500 A	
Rated short-time withstand current I _{cw} at 40 °C ambient temperature, in free air from a cold state	1 s	13000 A	
	10 s	11000 A	
	30 s	6000 A	
	1 min	4200 A	
	15 min	2200 A	
Maximum breaking capacity at U _e (L / R ≤ 15 ms)	550 V	22000 A	22000 A
	750 V	18000 A	22000 A
	1000 V	12000 A	18000 A
	1 500 V	8000 A	12000 A
	2 250 V	-	8000 A
Maximum making capacity		21000 A	
Dynamical withstand of pole		21000 A	
Impedance per pole		0.12 mΩ	

N.C. de-energisation pole - Utilization characteristics

Types	Single tripping coil	AM-CC-JORE1700-21	AM-CC-JORE1700-31
	Double tripping coil	AMF-CC-JORE1700-21	AMF-CC-JORE1700-31
Number of N.C. de-energisation pole		1	
Conventional free-air thermal current I _{th}			
Open contactors	θ ≤ 40 °C	1000 A	
With conductor cross-sectional area		500 mm ²	
Maximum making capacity		9000 A	
Rated short time current	0.5 s	10000 A	
	15 s	6000 A	
Maximum breaking capacity at U _e		No breaking capacity	
Impedance per pole		0.18 mΩ	

General technical data

Types	Single tripping coil	AM-CC-JORE1700-21	AM-CC-JORE1700-31
	Double tripping coil	AMF-CC-JORE1700-21	AMF-CC-JORE1700-31
Rated impulse withstand voltage U _{imp}		8 kV	
Dielectric test voltage / 1 min		5500 V AC 50 Hz	6000 V AC 50 Hz
Ambient air temperature close to contactor			
Operation in free air		-20...+55 °C	
Storage		-20...+80 °C	
Climatic withstand		Standard version for industrial environment and atmospheres	
Maximum operating altitude (without derating)		2000 m	
Mechanical durability			
Number of operating cycles		200000 cycles	

Construction characteristics

Types	Single tripping coil	AM-CC-JORE1700-21	AM-CC-JORE1700-31
	Double tripping coil	AMF-CC-JORE1700-21	AMF-CC-JORE1700-31
Standard combination of auxiliary contacts		3 N.O. + 2 N.C.: 3 CA15-F (N.O.) + 2 CA15-O (N.C.)	2 N.O. + 2 N.C.: 2 CA15-F (N.O.) + 2 CA15-O (N.C.)
Maximum number of auxiliary contacts		5	5
Fixing dimensions (F)		20	20
Width		16	16
Weight		5	5
		635 mm	635 mm
		760 mm	760 mm
		760 mm	760 mm
		820 mm	820 mm
		920 mm	920 mm
		920 mm	920 mm
		725 mm	725 mm
		850 mm	850 mm
		850 mm	850 mm
		910 mm	910 mm
		1010 mm	1010 mm
		1010 mm	1010 mm
		72 kg	72 kg
		72 kg	72 kg
		73 kg	73 kg
		90 kg	90 kg
		90 kg	90 kg
		91 kg	91 kg

AM-CC-JORE1700 and AMF-CC-JORE1700 alternator field discharge contactors

Technical data



Magnet system characteristics

Types	Single tripping coil	AM-CC-JORE1700-21	AM-CC-JORE1700-31
	Double tripping coil	AMF-CC-JORE1700-21	AMF-CC-JORE1700-31
Coil operating limits acc. to IEC 60947-4-1		At $\theta \leq 55^\circ\text{C}$ 0.85...1.1 x U_c	
DC control voltage		24...220 V DC	
Rated control circuit voltage U_c Coil consumption	Average pull-in value	950 W	950 W
	Tripping	265 W	265 W
Operating time (average values for U_c)			
Closing time		85 ms	
Opening time		50 ms	

Mounting characteristics

Types	Single tripping coil	AM-CC-JORE1700-21	AM-CC-JORE1700-31
	Double tripping coil	AMF-CC-JORE1700-21	AMF-CC-JORE1700-31
Fixing by screws (not supplied)		4 x M12	4 x M12

Connecting characteristics

Types	Single tripping coil	AM-CC-JORE1700-21	AM-CC-JORE1700-31
	Double tripping coil	AMF-CC-JORE1700-21	AMF-CC-JORE1700-31
Connection capacity (min. ... max.)			
Main conductors (poles)			
Terminal plates width		80 mm	
Terminal screw (not supplied)		-	
Drilling holes (without thread)		4 x $\varnothing 11$ mm	
Auxiliary conductors (built-in auxiliary terminals + coil terminals)			
 Rigid solid	1 or 2 x	1...2.5 mm ²	
 Flexible with non insulated ferrule	1 or 2 x	1...2.5 mm ²	
Tightening torque			
Coil terminals		1.5 Nm	
Built-in auxiliary terminals		1.5 Nm	
Screw terminals			
Main terminals		Screws and bolts	
Coil terminals		M4 with cable clamps	
Built-in auxiliary terminals		M4 with cable clamps	



AM-CC-JORE2100 and AMF-CC-JORE2100 alternator field discharge contactors

Technical data

N.O. main pole - Utilization characteristics

Types	Single tripping coil	AM-CC-JORE2100-21	AM-CC-JORE2100-31
	Double tripping coil	AMF-CC-JORE2100-21	AMF-CC-JORE2100-31
Number of N.O. poles in series		2	3
Rated operational voltage Ue		750 V DC	1000 V DC
Maximum breaking voltage		1500 V DC	2250 V DC
Conventional free-air thermal current Ith			
Open contactors	$\theta \leq 40\text{ °C}$	2000 A	
With conductor cross-sectional area		1500 mm ²	
Ie / Rated operational current	$\theta \leq 40\text{ °C}$	2000 A	
	$\theta \leq 50\text{ °C}$	1750 A	
Rated short-time withstand current Icw	1 s	15000 A	
at 40 °C ambient temperature,	10 s	12000 A	
in free air from a cold state	30 s	7000 A	
	1 min	4600 A	
	15 min	2600 A	
Maximum breaking capacity at Ue	550 V	22000 A	22000 A
(L / R \leq 15 ms)	750 V	18000 A	22000 A
	1000 V	12000 A	18000 A
	1500 V	8000 A	12000 A
	2250 V	-	8000 A
Maximum making capacity		24000 A	
Dynamical withstand of pole		24000 A	
Impedance per pole		0.10 m Ω	

N.C. de-energisation pole - Utilization characteristics

Types	Single tripping coil	AM-CC-JORE2100-21	AM-CC-JORE2100-31
	Double tripping coil	AMF-CC-JORE2100-21	AMF-CC-JORE2100-31
Number of N.C. de-energisation pole		1	
Conventional free-air thermal current Ith			
Open contactors	$\theta \leq 40\text{ °C}$	1000 A	
With conductor cross-sectional area		500 mm ²	
Maximum making capacity		9000 A	
Rated short time current	0.5 s	10000 A	
	15 s	6000 A	
Maximum breaking capacity at Ue		No breaking capacity	
Impedance per pole		0.8 m Ω	

General technical data

Types	Single tripping coil	AM-CC-JORE2100-21	AM-CC-JORE2100-31
	Double tripping coil	AMF-CC-JORE2100-21	AMF-CC-JORE2100-31
Rated impulse withstand voltage Uimp.		8 kV	
Dielectric test voltage / 1 min		5500 V AC 50 Hz	6000 V AC 50 Hz
Ambient air temperature close to contactor			
Operation in free air		-20...+55 °C	
Storage		-20...+80 °C	
Climatic withstand		Standard version for industrial environment and atmospheres	
Maximum operating altitude (without derating)		2000 m	
Mechanical durability			
Number of operating cycles		200000 cycles	

Construction characteristics

Types	Single tripping coil	AM-CC-JORE2100-21	AM-CC-JORE2100-31
	Double tripping coil	AMF-CC-JORE2100-21	AMF-CC-JORE2100-31
Standard combination of auxiliary contacts		3 N.O. + 2 N.C.: 3 CA15-F (N.O.) + 2 CA15-O (N.C.)	2 N.O. + 2 N.C.: 3 CA15-F (N.O.) + 2 CA15-O (N.C.)
Maximum number of auxiliary contacts		5	20
Fixing dimensions (F)		635 mm	760 mm
Width		725 mm	850 mm
Weight		80 kg	80 kg

AM-CC-JORE2100 and AMF-CC-JORE2100 alternator field discharge contactors

Technical data



Magnet system characteristics

Types	Single tripping coil	AM-CC-JORE2100-21	AM-CC-JORE2100-31
	Double tripping coil	AMF-CC-JORE2100-21	AMF-CC-JORE2100-31
Coil operating limits acc. to IEC 60947-4-1		At $\theta \leq 55^\circ\text{C}$ 0.85...1.1 x U_c	
DC control voltage		24...220 V DC	
Rated control circuit voltage U_c Coil consumption	Average pull-in value	950 W	950 W
	Tripping	265 W	265 W
Operating time (average values for U_c)			
Closing time		85 ms	
Opening time		45 ms	

Mounting characteristics

Types	Single tripping coil	AM-CC-JORE2100-21	AM-CC-JORE2100-31
	Double tripping coil	AMF-CC-JORE2100-21	AMF-CC-JORE2100-31
Fixing by screws (not supplied)		4 x M12	4 x M12

Connecting characteristics

Types	Single tripping coil	AM-CC-JORE2100-21	AM-CC-JORE2100-31
	Double tripping coil	AMF-CC-JORE2100-21	AMF-CC-JORE2100-31
Connection capacity (min. ... max.)			
Main conductors (poles)			
Terminal plates width		100 mm	
Terminal screw (not supplied)		-	
Drilling holes (without thread)		4 x $\varnothing 11$ mm	
Auxiliary conductors (built-in auxiliary terminals + coil terminals)			
	Rigid solid	1 or 2 x	1...2.5 mm ²
	Flexible with non insulated ferrule	1 or 2 x	1...2.5 mm ²
Tightening torque			
Coil terminals		1.5 Nm	
Built-in auxiliary terminals		1.5 Nm	
Screw terminals			
Main terminals		Screws and bolts	
Coil terminals		M4 with cable clamps	
Built-in auxiliary terminals		M4 with cable clamps	



AM-CC-JORE2500 and AMF-CC-JORE2500 alternator field discharge contactors

Technical data

N.O. main pole - Utilization characteristics

Types	Single tripping coil	AM-CC-JORE2500-21		AM-CC-JORE2500-31	
	Double tripping coil	AMF-CC-JORE2500-21		AMF-CC-JORE2500-31	
Number of N.O. poles in series		2		3	
Rated operational voltage Ue		750 V DC		1000 V DC	
Maximum breaking voltage		1500 V DC		2250 V DC	
Conventional free-air thermal current Ith					
Open contactors	$\theta \leq 40\text{ °C}$	2300 A			
With conductor cross-sectional area		2000 mm ²			
Ie / Rated operational current	$\theta \leq 40\text{ °C}$	2300 A			
	$\theta \leq 50\text{ °C}$	2100 A			
Rated short-time withstand current Icw	1 s	20000 A			
at 40 °C ambient temperature,	10 s	15000 A			
in free air from a cold state	30 s	8000 A			
	1 min	6000 A			
	15 min	3000 A			
Maximum breaking capacity at Ue	550 V	23000 A		23000 A	
(L / R ≤ 15 ms)	750 V	18000 A		23000 A	
	1000 V	14000 A		18000 A	
	1 500 V	8000 A		14000 A	
	2 250 V	-		8000 A	
Maximum making capacity		24000 A			
Dynamical withstand of pole		24000 A			
Impedance per pole		0.09 mΩ			

N.C. de-energisation pole - Utilization characteristics

Types	Single tripping coil	AM-CC-JORE2500-21		AM-CC-JORE2500-31	
	Double tripping coil	AMF-CC-JORE2500-21		AMF-CC-JORE2500-31	
Number of N.C. de-energisation pole		1			
Conventional free-air thermal current Ith					
Open contactors	$\theta \leq 40\text{ °C}$	1000 A			
With conductor cross-sectional area		500 mm ²			
Maximum making capacity		9000 A			
Rated short time current	0.5 s	10000 A			
	15 s	6000 A			
Maximum breaking capacity at Ue		No breaking capacity			
Impedance per pole		0.18 mΩ			

General technical data

Types	Single tripping coil	AM-CC-JORE2500-21		AM-CC-JORE2500-31	
	Double tripping coil	AMF-CC-JORE2500-21		AMF-CC-JORE2500-31	
Rated impulse withstand voltage Uimp.		8 kV			
Dielectric test voltage / 1 min		5500 V AC 50 Hz		6000 V AC 50 Hz	
Ambient air temperature close to contactor					
Operation in free air		-20...+55 °C			
Storage		-20...+80 °C			
Climatic withstand		Standard version for industrial environment and atmospheres			
Maximum operating altitude (without derating)		2000 m			
Mechanical durability					
Number of operating cycles		200000 cycles			

Construction characteristics

Types	Single tripping coil	AM-CC-JORE2500-21		AM-CC-JORE2500-31	
	Double tripping coil	AMF-CC-JORE2500-21		AMF-CC-JORE2500-31	
Standard combination of auxiliary contacts		3 N.O. + 2 N.C.: 3 CA15-F (N.O.) + 2 CA15-O (N.C.)		2 N.O. + 2 N.C.: 2 CA15-F (N.O.) + 2 CA15-O (N.C.)	
Maximum number of auxiliary contacts		5	20	5	20
Fixing dimensions (F)		885 mm	985 mm	985 mm	1150 mm
Width		975 mm	1075 mm	1075 mm	1240 mm
Weight		85 kg	85 kg	86 kg	120 kg
					122 kg
					123 kg

AM-CC-JORE2500 and AMF-CC-JORE2500 alternator field discharge contactors

Technical data



Magnet system characteristics

Types	Single tripping coil	AM-CC-JORE2500-21	AM-CC-JORE2500-31
	Double tripping coil	AMF-CC-JORE2500-21	AMF-CC-JORE2500-31
Coil operating limits acc. to IEC 60947-4-1		At $\theta \leq 55^\circ\text{C}$ 0.85...1.1 x U _c	
DC control voltage		24...220 V DC	
Rated control circuit voltage U _c Coil consumption	Average pull-in value	950 W	950 W
	Tripping	265 W	265 W
Operating time (average values for U_c)			
Closing time		85 ms	
Opening time		50 ms	

Mounting characteristics

Types	Single tripping coil	AM-CC-JORE2500-21	AM-CC-JORE2500-31
	Double tripping coil	AMF-CC-JORE2500-21	AMF-CC-JORE2500-31
Fixing by screws (not supplied)		4 x M12	4 x M12

Connecting characteristics

Types	Single tripping coil	AM-CC-JORE2500-21	AM-CC-JORE2500-31
	Double tripping coil	AMF-CC-JORE2500-21	AMF-CC-JORE2500-31
Connection capacity (min. ... max.)			
Main conductors (poles)			
Terminal plates width		150 mm	
Terminal screw (not supplied)		-	
Drilling holes (without thread)		8 x \varnothing 9 mm	
Auxiliary conductors (built-in auxiliary terminals + coil terminals)			
	Rigid solid	1 or 2 x	1...2.5 mm ²
	Flexible with non insulated ferrule	1 or 2 x	1...2.5 mm ²
Tightening torque			
Coil terminals		1.5 Nm	
Built-in auxiliary terminals		1.5 Nm	
Screw terminals			
Main terminals		Screws and bolts	
Coil terminals		M4 with cable clamps	
Built-in auxiliary terminals		M4 with cable clamps	



AM-CC-JORE3200 and AMF-CC-JORE3200 alternator field discharge contactors

Technical data

N.O. main pole - Utilization characteristics

Types	Single tripping coil	AM-CC-JORE3200-21	AM-CC-JORE3200-31	
	Double tripping coil	AMF-CC-JORE3200-21	AMF-CC-JORE3200-31	
Number of N.O. poles in series		2	3	
Rated operational voltage U _e		750 V DC	1000 V DC	
Maximum breaking voltage		1500 V DC	2250 V DC	
Conventional free-air thermal current I _{th}				
Open contactors	θ ≤ 40 °C	3200 A		
With conductor cross-sectional area		3000 mm ²		
I _e / Rated operational current	θ ≤ 40 °C	3200 A		
	θ ≤ 50 °C	3000 A		
Rated short-time withstand current I _{cw} at 40 °C ambient temperature, in free air from a cold state	1 s	21000 A		
	10 s	18000 A		
	30 s	10000 A		
	1 min	7000 A		
	15 min	4000 A		
Maximum breaking capacity at U _e (L / R ≤ 15 ms)	550 V	25000 A	25000 A	
	750 V	22000 A	25000 A	
	1000 V	20000 A	22000 A	
	1 500 V	9000 A	18000 A	
	2 250 V	-	9000 A	
Maximum making capacity		26000 A		
Dynamical withstand of pole		26000 A		
Impedance per pole		0.06 mΩ		

N.C. de-energisation pole - Utilization characteristics

Types	Single tripping coil	AM-CC-JORE3200-21	AM-CC-JORE3200-31	
	Double tripping coil	AMF-CC-JORE3200-21	AMF-CC-JORE3200-31	
Number of N.C. de-energisation pole		1		
Conventional free-air thermal current I _{th}				
Open contactors	θ ≤ 40 °C	1000 A		
With conductor cross-sectional area		500 mm ²		
Maximum making capacity		9000 A		
Rated short time current	0.5 s	10000 A		
	15 s	6000 A		
Maximum breaking capacity at U _e		No breaking capacity		
Impedance per pole		0.18 mΩ		

General technical data

Types	Single tripping coil	AM-CC-JORE3200-21	AM-CC-JORE3200-31	
	Double tripping coil	AMF-CC-JORE3200-21	AMF-CC-JORE3200-31	
Rated impulse withstand voltage U _{imp}		8 kV		
Dielectric test voltage / 1 min		5500 V AC 50 Hz	6000 V AC 50 Hz	
Ambient air temperature close to contactor				
Operation in free air		-20...+55 °C		
Storage		-20...+80 °C		
Climatic withstand		Standard version for industrial environment and atmospheres		
Maximum operating altitude (without derating)		2000 m		
Mechanical durability				
Number of operating cycles		200000 cycles		

Construction characteristics

Types	Single tripping coil	AM-CC-JORE3200-21		AM-CC-JORE3200-31	
	Double tripping coil	AMF-CC-JORE3200-21		AMF-CC-JORE3200-31	
Standard combination of auxiliary contacts		3 N.O. + 2 N.C.:	2 N.O. + 2 N.C.:	3 N.O. + 2 N.C.:	2 N.O. + 2 N.C.:
		3 CA15-F (N.O.)	2 CA15-F (N.O.)	3 CA15-F (N.O.)	2 CA15-F (N.O.)
		+ 2 CA15-O (N.C.)	+ 2 CA15-O (N.C.)	+ 2 CA15-O (N.C.)	+ 2 CA15-O (N.C.)
Maximum number of auxiliary contacts		5	20	5	20
Fixing dimensions (F)		885 mm	985 mm	985 mm	1150 mm
					1250 mm
Width		975 mm	1075 mm	1075 mm	1240 mm
					1340 mm
Weight		102 kg	104 kg	105 kg	120 kg
					122 kg
					123 kg

AM-CC-JORE3200 and AMF-CC-JORE3200 alternator field discharge contactors

Technical data



Magnet system characteristics

Types	Single tripping coil	AM-CC-JORE3200-21	AM-CC-JORE3200-31
	Double tripping coil	AMF-CC-JORE3200-21	AMF-CC-JORE3200-31
Coil operating limits acc. to IEC 60947-4-1			
		At $\theta \leq 55^\circ\text{C}$ 0.85...1.1 x U _c	
DC control voltage			
Rated control circuit voltage U _c		24...220 V DC	
Coil consumption	Average pull-in value	985 W	985 W
	Tripping	265 W	265 W
Operating time (average values for U_c)			
Closing time		90 ms	135 ms
Opening time		45 ms	45 ms

Mounting characteristics

Types	Single tripping coil	AM-CC-JORE3200-21	AM-CC-JORE3200-31
	Double tripping coil	AMF-CC-JORE3200-21	AMF-CC-JORE3200-31
Fixing by screws (not supplied)			
		4 or 6 x M12	4 or 6 x M12

Connecting characteristics

Types	Single tripping coil	AM-CC-JORE3200-21	AM-CC-JORE3200-31
	Double tripping coil	AMF-CC-JORE3200-21	AMF-CC-JORE3200-31
Connection capacity (min. ... max.)			
Main conductors (poles)			
Terminal plates width		180 mm	
Terminal screw (not supplied)		-	
Drilling holes (without thread)		8 x \varnothing 13 mm	
Auxiliary conductors (built-in auxiliary terminals + coil terminals)			
	Rigid solid	1 or 2 x	1...2.5 mm ²
	Flexible with non insulated ferrule	1 or 2 x	1...2.5 mm ²
Tightening torque			
Coil terminals		1.5 Nm	
Built-in auxiliary terminals		1.5 Nm	
Screw terminals			
Main terminals		Screws and bolts	
Coil terminals		M4 with cable clamps	
Built-in auxiliary terminals		M4 with cable clamps	



AM-CC-JORE3800 and AMF-CC-JORE3800 alternator field discharge contactors

Technical data

N.O. main pole - Utilization characteristics

Types	Single tripping coil	AM-CC-JORE3800-21	AM-CC-JORE3800-31	
	Double tripping coil	AMF-CC-JORE3800-21	AMF-CC-JORE3800-31	
Number of N.O. poles in series		2	3	
Rated operational voltage Ue		750 V DC	1000 V DC	
Maximum breaking voltage		1500 V DC	2250 V DC	
Conventional free-air thermal current Ith				
Open contactors	$\theta \leq 40\text{ }^{\circ}\text{C}$	3800 A		
With conductor cross-sectional area		4000 mm ²		
Ie / Rated operational current	$\theta \leq 40\text{ }^{\circ}\text{C}$	3800 A		
	$\theta \leq 50\text{ }^{\circ}\text{C}$	3500 A		
Rated short-time withstand current Icw at 40 °C ambient temperature, in free air from a cold state	1 s	24000 A		
	10 s	19000 A		
	30 s	11000 A		
	1 min	7500 A		
	15 min	4500 A		
Maximum breaking capacity at Ue (L / R \leq 15 ms)	550 V	25000 A	25000 A	
	750 V	22000 A	25000 A	
	1000 V	20000 A	22000 A	
	1 500 V	9000 A	18000 A	
	2 250 V	-	9000 A	
Maximum making capacity		29000 A		
Dynamical withstand of pole		29000 A		
Impedance per pole		0.05 m Ω		

N.C. de-energisation pole - Utilization characteristics

Types	Single tripping coil	AM-CC-JORE3800-21	AM-CC-JORE3800-31	
	Double tripping coil	AMF-CC-JORE3800-21	AMF-CC-JORE3800-31	
Number of N.C. de-energisation pole		1		
Conventional free-air thermal current Ith				
Open contactors	$\theta \leq 40\text{ }^{\circ}\text{C}$	1000 A		
With conductor cross-sectional area		500 mm ²		
Maximum making capacity		9000 A		
Rated short time current	0.5 s	10000 A		
	15 s	6000 A		
Maximum breaking capacity at Ue		No breaking capacity		
Impedance per pole		0.18 m Ω		

General technical data

Types	Single tripping coil	AM-CC-JORE3800-21	AM-CC-JORE3800-31	
	Double tripping coil	AMF-CC-JORE3800-21	AMF-CC-JORE3800-31	
Rated impulse withstand voltage Uimp.		8 kV		
Dielectric test voltage / 1 min		5500 V AC 50 Hz	6000 V AC 50 Hz	
Ambient air temperature close to contactor				
Operation in free air		-20...+55 °C		
Storage		-20...+80 °C		
Climatic withstand		Standard version for industrial environment and atmospheres		
Maximum operating altitude (without derating)		2000 m		
Mechanical durability				
Number of operating cycles		200000 cycles		

Construction characteristics

Types	Single tripping coil	AM-CC-JORE3800-21		AM-CC-JORE3800-31	
	Double tripping coil	AMF-CC-JORE3800-21		AMF-CC-JORE3800-31	
Standard combination of auxiliary contacts		3 N.O. + 2 N.C.:	2 N.O. + 2 N.C.:	3 N.O. + 2 N.C.:	2 N.O. + 2 N.C.:
		3 CA15-F (N.O.)	2 CA15-F (N.O.)	3 CA15-F (N.O.)	2 CA15-F (N.O.)
		+ 2 CA15-O (N.C.)	+ 2 CA15-O (N.C.)	+ 2 CA15-O (N.C.)	+ 2 CA15-O (N.C.)
Maximum number of auxiliary contacts		5	20	5	20
Fixing dimensions (F)		950 mm	1050 mm	1050 mm	1200 mm
					1300 mm
Width		1040 mm	1140 mm	1140 mm	1290 mm
					1390 mm
Weight		110 kg	112 kg	113 kg	129 kg
					131 kg
					132 kg

AM-CC-JORE3800 and AMF-CC-JORE3800 alternator field discharge contactors

Technical data



Magnet system characteristics

Types	Single tripping coil	AM-CC-JORE3800-21	AM-CC-JORE3800-31
	Double tripping coil	AMF-CC-JORE3800-21	AMF-CC-JORE3800-31
Coil operating limits acc. to IEC 60947-4-1		At $\theta \leq 55^\circ\text{C}$ 0.85...1.1 x U _c	
DC control voltage		24...220 V DC	
Rated control circuit voltage U _c Coil consumption	Average pull-in value	985 W	1250 W
	Tripping	265 W	265 W
Operating time (average values for U_c)			
Closing time		100 ms	140 ms
Opening time		45 ms	40 ms

Mounting characteristics

Types	Single tripping coil	AM-CC-JORE3800-21	AM-CC-JORE3800-31
	Double tripping coil	AMF-CC-JORE3800-21	AMF-CC-JORE3800-31
Fixing by screws (not supplied)		4 or 6 x M12	4 or 6 x M12

Connecting characteristics

Types	Single tripping coil	AM-CC-JORE3800-21	AM-CC-JORE3800-31
	Double tripping coil	AMF-CC-JORE3800-21	AMF-CC-JORE3800-31
Connection capacity (min. ... max.)			
Main conductors (poles)			
Terminal plates width		220 mm	
Terminal screw (not supplied)		-	
Drilling holes (without thread)		8 x \varnothing 13 mm	
Auxiliary conductors (built-in auxiliary terminals + coil terminals)			
	Rigid solid	1 or 2 x	1...2.5 mm ²
	Flexible with non insulated ferrule	1 or 2 x	1...2.5 mm ²
Tightening torque			
Coil terminals		1.5 Nm	
Built-in auxiliary terminals		1.5 Nm	
Screw terminals			
Main terminals		Screws and bolts	
Coil terminals		M4 with cable clamps	
Built-in auxiliary terminals		M4 with cable clamps	



AM-CC-JORE4500 and AMF-CC-JORE4500 alternator field discharge contactors

Technical data

N.O. main pole - Utilization characteristics

Types	Single tripping coil	AM-CC-JORE4500-21	
	Double tripping coil	AMF-CC-JORE4500-21	
Number of N.O. poles in series		2	
Rated operational voltage U _e		750 V DC	
Maximum breaking voltage		1500 V DC	
Conventional free-air thermal current I _{th}			
Open contactors	θ ≤ 40 °C	4500 A	
With conductor cross-sectional area		4000 mm ²	
I _e / Rated operational current	θ ≤ 40 °C	4500 A	
	θ ≤ 50 °C	4100 A	
Rated short-time withstand current I _{cw} at 40 °C ambient temperature, in free air from a cold state	1 s	28000 A	
	10 s	21000 A	
	30 s	12000 A	
	1 min	8000 A	
	15 min	5000 A	
Maximum breaking capacity at U _e (L / R ≤ 15 ms)	550 V	25000 A	
	750 V	22000 A	
	1000 V	20000 A	
	1 500 V	10000 A	
	2 250 V	-	
Maximum making capacity		32000 A	
Dynamical withstand of pole		32000 A	
Impedance per pole		0.04 mΩ	

N.C. de-energisation pole - Utilization characteristics

Types	Single tripping coil	AM-CC-JORE4500-21	
	Double tripping coil	AMF-CC-JORE4500-21	
Number of N.C. de-energisation pole		1	
Conventional free-air thermal current I _{th}			
Open contactors	θ ≤ 40 °C	1000 A	
With conductor cross-sectional area		500 mm ²	
Maximum making capacity		9000 A	
Rated short time current	0.5 s	10000 A	
	15 s	6000 A	
Maximum breaking capacity at U _e		No breaking capacity	
Impedance per pole		0.18 mΩ	

General technical data

Types	Single tripping coil	AM-CC-JORE4500-21	
	Double tripping coil	AMF-CC-JORE4500-21	
Rated impulse withstand voltage U _{imp}		8 kV	
Dielectric test voltage / 1 min		5500 V AC 50 Hz	
Ambient air temperature close to contactor			
Operation in free air		-20...+55 °C	
Storage		-20...+80 °C	
Climatic withstand		Standard version for industrial environment and atmospheres	
Maximum operating altitude (without derating)		2000 m	
Mechanical durability			
Number of operating cycles		200000 cycles	

Construction characteristics

Types	Single tripping coil	AM-CC-JORE4500-21	
	Double tripping coil	AMF-CC-JORE4500-21	
Standard combination of auxiliary contacts		3 N.O. + 2 N.C.:	
		3 CA15-F (N.O.)	
		+ 2 CA15-O (N.C.)	
Maximum number of auxiliary contacts	5	20	16
Fixing dimensions (F)	1100 mm	1200 mm	1200 mm
Width	1190 mm	1290 mm	1290 mm
Weight	135 kg	136 kg	137 kg

AM-CC-JORE4500 and AMF-CC-JORE4500 alternator field discharge contactors

Technical data



Magnet system characteristics

Types	Single tripping coil	AM-CC-JORE4500-21	
	Double tripping coil		AMF-CC-JORE4500-21
Coil operating limits acc. to IEC 60947-4-1			
		At $\theta \leq 55^\circ\text{C}$ 0.85...1.1 x U _c	
DC control voltage			
Rated control circuit voltage U _c		24...220 V DC	
Coil consumption	Average pull-in value	1250 W	
	Tripping	265 W	
Operating time (average values for U_c)			
Closing time		140 ms	
Opening time		40 ms	

Mounting characteristics

Types	Single tripping coil	AM-CC-JORE4500-21	
	Double tripping coil		AMF-CC-JORE4500-21
Fixing by screws (not supplied)			
		4 or 6 x M12	

Connecting characteristics

Types	Single tripping coil	AM-CC-JORE4500-21	
	Double tripping coil		AMF-CC-JORE4500-21
Connection capacity (min. ... max.)			
Main conductors (poles)			
Terminal plates width		280 mm	
Terminal screw (not supplied)		-	
Drilling holes (without thread)		12 x ø11 mm	
Auxiliary conductors (built-in auxiliary terminals + coil terminals)			
	Rigid solid	1 or 2 x	1...2.5 mm ²
	Flexible with non insulated ferrule	1 or 2 x	1...2.5 mm ²
Tightening torque			
Coil terminals		1.5 Nm	
Built-in auxiliary terminals		1.5 Nm	
Screw terminals			
Main terminals		Screws and bolts	
Coil terminals		M4 with cable clamps	
Built-in auxiliary terminals		M4 with cable clamps	





General technical data

[Technical data](#) 6/2

[Electrical durability](#) 6/7



R contactors

Technical data

General technical data

Contactor types	IOR, LOR, NOR contactors
Standards	IEC 60947-1 / 60947-4-1 and EN 60947-1 / 60947-4-1
Rated insulation voltage Ui acc. to IEC 60947-4-1 and EN 60947-4-1	
R63 ... R500	1000 V AC or 1000 V DC (1500 V DC with increased insulation)
R800 ... R5100	1000 V AC or 1500 V DC
Rated impulse withstand voltage Uimp.	8 kV
Ambient air temperature close to contactor	
Operation	-20...+70 °C
Storage	-20...+80 °C
Climatic withstand	Standard version for industrial environment and atmospheres
Maximum operating altitude (without derating)	2000 m

Mounting characteristics and condition for use

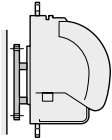
Contactor types	IOR, LOR, NOR contactors
Mounting positions	Position 1 (horizontal bar)
	
	Maximum angle of inclination, in any direction : $\pm 22^{\circ} 30'$
Mounting distances	See "Dimensions"



R contactors

Technical data

Types	IORR63..MT IORR63..CC LORR85	IORR125..MT IORR125..CC LORR170	IORR200..MT IORR200..CC LORR260	IORR400..MT IORR400..CC LORR400	IORR500..MT IORR500..CC LORR550
-------	------------------------------------	---------------------------------------	---------------------------------------	---------------------------------------	---------------------------------------

Magnet system characteristics

Coil operating limits acc. to IEC 60947-4-1	At $\theta \leq 55^\circ\text{C}$ 0.85...1.1 x U _c					
AC control voltage 50/60 Hz						
Rated control circuit voltage U _c	24...550 V AC					
Coil consumption	Average pull-in value	290 VA	460 VA	410 VA	540 VA	540 VA
	Average holding value	25 VA	45 VA	45 VA	65 VA	65 VA
Drop-out voltage	20...75 % of U _c					
Operating time (average values for U _c)						
Between coil energization and N.O. contact closing	30 ms	30 ms	40 ms	60 ms	60 ms	
Between coil de-energization and N.O. contact opening	20 ms	20 ms	20 ms	50 ms	50 ms	

Types	IORE63..MT IORE63..CC LORE85	IORE125..MT IORE125..CC LORE170	IORE200..MT IORE200..CC LORE260	IORE400..MT IORE400..CC LORE400	IORE500..MT IORE500..CC LORE550
-------	------------------------------------	---------------------------------------	---------------------------------------	---------------------------------------	---------------------------------------

Magnet system characteristics



Coil operating limits acc. to IEC 60947-4-1	At $\theta \leq 55^\circ\text{C}$ 0.85...1.1 x U _c					
DC control voltage						
Rated control circuit voltage U _c	24...600 V DC					
Coil consumption	Average pull-in value	265 W	330 W	330 W	360 W	360 W
	Average holding value	30 W	45 W	45 W	50 W	50 W
Drop-out voltage	10...75 % of U _c					
Operating time (average values for U _c)						
Between coil energization and N.O. contact closing	30 ms	30 ms	40 ms	60 ms	60 ms	
Between coil de-energization and N.O. contact opening	20 ms	20 ms	20 ms	45 ms	45 ms	

Types	IORR/IORE63..MT IORR/IORE63..CC LORR/LORE85	IORR/IORE125..MT IORR/IORE125..CC LORR/LORE170	IORR/IORE200..MT IORR/IORE200..CC LORR/LORE260	IORR/IORE400..MT IORR/IORE400..CC LORR/LORE400	IORR/IORE500..MT IORR/IORE500..CC LORR/LORE550
-------	---	--	--	--	--

Mounting characteristics

Fixing by screws (not supplied)	2 x M6	2 x M6	2 x M8	2 x M12	2 x M12
---------------------------------	--------	--------	--------	---------	---------

Connecting characteristics

Main terminals	Terminal plates for lugs or bars				
Connection capacity (min. ... max.)					
Main conductors (poles)					
Terminal plates width	16 mm	20 mm	25 mm	30 mm	30 mm
Terminal screw (not supplied)	M6 x 20	M8 x 20	M10 x 25	-	-
Drilling holes (without thread)	-	-	-	1 x ϕ 13 mm	1 x ϕ 13 mm
Auxiliary conductors					
(built-in auxiliary terminals + coil terminals)					
 Rigid solid	1 or 2 x	1...2.5 mm ²			
 Flexible without ferrule	1 or 2 x	1...2.5 mm ²			
Tightening torque					
Coil terminals	1.5 Nm				
Built-in auxiliary terminals	1.5 Nm				
Screw terminals					
Main terminals	Screws and bolts				
Coil terminals	M4 with cable clamps				
Built-in auxiliary terminals	M4 with cable clamps				

R contactors

Technical data

Types	IORR800 LORR800 IORR800..MT IORR800..CC	IORR1000 IORR1000..CC FORR1000	IORR1400 LORR1400 IORR1400..MT IORR1400..CC FORR1400	IORR1700 LORR1700 IORR1700..MT IORR1700..CC FORR1700	IORR2100 LORR2100 IORR2100..MT IORR2100..CC FORR2100
--------------	--	--	--	--	--

Magnet system characteristics

Coil operating limits acc. to IEC 60947-4-1	At $\theta \leq 55^\circ\text{C}$ $0.85 \dots 1.1 \times U_c$				
AC control voltage 50/60 Hz	24...550 V AC				
Rated control circuit voltage U_c	24...550 V AC		2 and 3 poles: 610 VA	2...4 poles: 925 VA	
Coil consumption	Average pull-in value	610 VA	4 poles: 925 VA		
	Average holding value	55 VA	2 and 3 poles: 55 VA	2...4 poles: 130 VA	
			4 poles: 130 VA		
Drop-out voltage	20...75 % of U_c				
Operating time (average values for U_c)					
Between coil energization and N.O. contact closing	100 ms	100 ms	100 ms	90 ms	90 ms
Between coil de-energization and N.O. contact opening	55 ms	55 ms	55 ms	40 ms	30 ms

6

Types	IORE800 LORE800 IORE800..MT IORE800..CC	IORE1000 IORE1000..CC FORE1000	IORE1400 LORE1400 IORE1400..MT IORE1400..CC FORE1400	IORE1700 LORE1700 IORE1700..MT IORE1700..CC FORE1700	IORE2100 LORE2100 IORE2100..MT IORE2100..CC FORE2100
--------------	--	--	--	--	--

Magnet system characteristics

Coil operating limits acc. to IEC 60947-4-1	At $\theta \leq 55^\circ\text{C}$ $0.85 \dots 1.1 \times U_c$				
DC control voltage	24...600 V DC				
Rated control circuit voltage U_c	24...600 V DC		2...4 poles: 930 W		
Coil consumption	Average pull-in value	700 W	2...4 poles: 110 W		
	Average holding value	55 W			
Drop-out voltage	10...75 % of U_c				
Operating time (average values for U_c)					
Between coil energization and N.O. contact closing	70 ms	70 ms	100 ms	90 ms	90 ms
Between coil de-energization and N.O. contact opening	50 ms	50 ms	55 ms	40 ms	30 ms



Types	IORR/IORE800 LORR/LORE800 IORR/IORE800..MT IORR/IORE800..CC	IORR/IORE1000 IORR/IORE1000..CC FORR/FORE1000	IORR/IORE1400 LORR/LORE1400 IORR/IORE1400..MT IORR/IORE1400..CC FORR/FORE1400	IORR/IORE1700 LORR/LORE1700 IORR/IORE1700..MT IORR/IORE1700..CC FORR/FORE1700	IORR/IORE2100 LORR/LORE2100 IORR/IORE2100..MT IORR/IORE2100..CC FORR/FORE2100
--------------	--	---	---	---	---

Mounting characteristics

Fixing by screws (not supplied)	4 x M12
--	---------

Connecting characteristics

Main terminals	Terminal plates for lugs or bars				
Connection capacity (min. ... max.)					
Main conductors (poles)					
Terminal plates width	48 mm	48 mm	60 mm	80 mm	100 mm
Drilling holes (without thread)	2 x $\varnothing 13$ mm	2 x $\varnothing 13$ mm	2 x $\varnothing 13$ mm	4 x $\varnothing 11$ mm	4 x $\varnothing 11$ mm
Auxiliary conductors (built-in auxiliary terminals + coil terminals)					
Rigid solid	1 or 2 x	1...2.5 mm ²			
Flexible without ferrule	1 or 2 x	1...2.5 mm ²			
Tightening torque					
Coil terminals	1.5 Nm				
Built-in auxiliary terminals	1.5 Nm				
Screw terminals					
Main terminals	Screws and bolts				
Coil terminals	M4 with cable clamps				
Built-in auxiliary terminals	M4 with cable clamps				

R contactors

Technical data

Types	IORR2500 LORR2500 IORR2500..MT IORR2500..CC FORR2500	IORR3200 LORR3200 IORR3200..MT IORR3200..CC FORR3200	IORR3800 LORR3800 IORR3800..MT IORR3800..CC FORR3800	IORR4500 LORR4500 IORR4500..MT IORR4500..CC	IORR5100 LORR5100 IORR5100..MT IORR5100..CC
--------------	--	--	--	--	--

Magnet system characteristics

Coil operating limits acc. to IEC 60947-4-1	At $\theta \leq 55^\circ\text{C}$ 0.85...1.1 x U _c					
AC control voltage 50/60 Hz	48...550 V AC					
Rated control circuit voltage U _c	48...550 V AC					
Coil consumption	Average pull-in value	1...4 poles: 925 VA	1...3 poles: 925 VA	1 and 2 poles: 925 VA	1 and 2 poles: 925 VA	1 pole: 925 VA
	Average holding value	1...4 poles: 130 VA	1...3 poles: 130 VA	1 and 2 poles: 130 VA	1 and 2 poles: 130 VA	1 pole: 130 VA
Drop-out voltage	20...75 % of U _c					
Operating time (average values for U_c)						
Between coil energization and N.O. contact closing	-					
Between coil de-energization and N.O. contact opening	-					

Types	IORE2500 LORE2500 IORE2500..MT IORE2500..CC FORE2500	IORE3200 LORE3200 IORE3200..MT IORE3200..CC FORE3200	IORE3800 LORE3800 IORE3800..MT IORE3800..CC FORE3800	IORE4500 LORE4500 IORE4500..MT IORE4500..CC	IORE5100 LORE5100 IORE5100..MT IORE5100..CC
--------------	--	--	--	--	--

Magnet system characteristics



Coil operating limits acc. to IEC 60947-4-1	At $\theta \leq 55^\circ\text{C}$ 0.85...1.1 x U _c					
DC control voltage	48...600 V DC					
Rated control circuit voltage U _c	48...600 V DC					
Coil consumption	Average pull-in value	1...4 poles: 930 W	1...3 poles: 930 W	1 and 2 poles: 930 W	1 and 2 poles: 930 W	1 pole: 930 W
	Average holding value	1...4 poles: 110 W	1...3 poles: 110 W	1 and 2 poles: 110 W	1 and 2 poles: 110 W	1 pole: 110 W
Drop-out voltage	10...75 % of U _c					
Operating time (average values for U_c)						
Between coil energization and N.O. contact closing	-					
Between coil de-energization and N.O. contact opening	-					

Types	IORR/IORE2500 LORR/LORE2500 IORR/IORE2500..MT IORR/IORE2500..CC FORR/FORE2500	IORR/IORE3200 LORR/LORE3200 IORR/IORE3200..MT IORR/IORE3200..CC FORR/FORE3200	IORR/IORE3800 LORR/LORE3800 IORR/IORE3800..MT IORR/IORE3800..CC FORR/FORE3800	IORR/IORE4500 LORR/LORE4500 IORR/IORE4500..MT IORR/IORE4500..CC	IORR/IORE5100 LORR/LORE5100 IORR/IORE5100..MT IORR/IORE5100..CC
--------------	---	---	---	--	--

Mounting characteristics

Fixing by screws (not supplied)	4 x M12	4 or 6 x M12
--	---------	--------------

Connecting characteristics

Main terminals	Terminal plates for lugs or bars				
Connection capacity (min. ... max.)					
Main conductors (poles)					
Terminal plates width	150 mm	180 mm	220 mm	280 mm	340 mm
Drilling holes (without thread)	8 x \varnothing 9 mm	8 x \varnothing 13 mm	8 x \varnothing 13 mm	12 x \varnothing 11 mm	14 x \varnothing 13 mm
Auxiliary conductors (built-in auxiliary terminals + coil terminals)					
 Rigid solid	1 or 2 x	1...2.5 mm ²			
 Flexible without ferrule	1 or 2 x	1...2.5 mm ²			
Tightening torque					
Coil terminals	1.5 Nm				
Built-in auxiliary terminals	1.5 Nm				
Screw terminals					
Main terminals	Screws and bolts				
Coil terminals	M4 with cable clamps				
Built-in auxiliary terminals	M4 with cable clamps				

R contactors

Technical data

Types	NORR63..MT NORR63..CC	NORR125..MT NORR125..CC	NORR200..MT NORR200..CC	NORR400	NORR800..MT NORR800..CC NORR800
-------	--------------------------	----------------------------	----------------------------	---------	---------------------------------------

Magnet system characteristics

Coil operating limits acc. to IEC 60947-4-1						
At $\theta \leq 55^\circ\text{C}$ $0.85 \dots 1.1 \times U_c$						
AC control voltage 50/60 Hz						
Rated control circuit voltage U_c 24...550 V AC						
Coil consumption						
	Average pull-in value	290 VA	460 VA	410 VA	540 VA	610 VA
	Average holding value	25 VA	45 VA	45 VA	65 VA	55 VA
Drop-out voltage 20...75 % of U_c						
Operating time (average values for U_c)						
For N.O. poles of the NORR						
Between coil energization and N.O. contact closing						
		30 ms	30 ms	40 ms	60 ms	100 ms
Between coil de-energization and N.O. contact opening						
		20 ms	20 ms	20 ms	50 ms	55 ms
For N.C. poles of the NORR						
Between coil energization and N.C. contact opening						
		27 ms	27 ms	37 ms	55 ms	85 ms
Between coil de-energization and N.C. contact closing						
		23 ms	23 ms	23 ms	28 ms	60 ms

6

Types	NORE63..MT NORE63..CC	NORE125..MT NORE125..CC	NORE200..MT NORE200..CC	NORE400	NORE800..MT NORE800..CC NORE800
-------	--------------------------	----------------------------	----------------------------	---------	---------------------------------------

Magnet system characteristics

Coil operating limits acc. to IEC 60947-4-1						
At $\theta \leq 55^\circ\text{C}$ $0.85 \dots 1.1 \times U_c$						
DC control voltage						
Rated control circuit voltage U_c 24...600 V DC						
Coil consumption						
	Average pull-in value	265 W	330 W	330 W	360 W	700 W
	Average holding value	30 W	45 W	45 W	50 W	55 W
Drop-out voltage 10...75 % of U_c						
Operating time (average values for U_c)						
For N.O. poles of the NORR						
Between coil energization and N.O. contact closing						
		30 ms	30 ms	40 ms	60 ms	70 ms
Between coil de-energization and N.O. contact opening						
		20 ms	20 ms	20 ms	45 ms	50 ms
For N.C. poles of the NORR						
Between coil energization and N.C. contact opening						
		27 ms	27 ms	37 ms	57 ms	62 ms
Between coil de-energization and N.C. contact closing						
		23 ms	23 ms	23 ms	28 ms	53 ms





Types	NORR/NORE63..MT NORR/NORE63..CC	NORR/NORE125..MT NORR/NORE125..CC	NORR/NORE200..MT NORR/NORE200..CC	NORR/NORE400	NORR/NORE800..MT NORR/NORE800..CC NORR/NORE800
-------	------------------------------------	--------------------------------------	--------------------------------------	--------------	--

Mounting characteristics

Fixing by screws (not supplied)	2 x M6	2 x M6	2 x M8	2 x M12	4 x M12
---------------------------------	--------	--------	--------	---------	---------

Connecting characteristics

Main terminals						
Terminal plates for lugs or bars						
Connection capacity (min. ... max.)						
Main conductors (poles)						
Terminal plates width						
		16 mm	20 mm	25 mm	30 mm	48 mm
Terminal screw (not supplied)						
		2 x M6	2 x M6	2 x M8	-	-
Drilling holes (without thread)						
		-	-	-	1 x $\varnothing 13$ mm	2 x $\varnothing 13$ mm
Auxiliary conductors (built-in auxiliary terminals + coil terminals)						
	Rigid solid	1 or 2 x	1...2.5 mm ²			
	Flexible without ferrule	1 or 2 x	1...2.5 mm ²			
Tightening torque						
Coil terminals						
		1.5 Nm				
Built-in auxiliary terminals						
		1.5 Nm				
Screw terminals						
Main terminals						
Coil terminals						
Built-in auxiliary terminals						
		Screws and bolts				
		M4 with cable clamps				
		M4 with cable clamps				

R contactors

Electrical durability and utilization categories

General

Utilization categories determine the current making and breaking conditions relating to the characteristics of the loads to be controlled by the contactors. International standard IEC 60947-4-1 and European standard EN 60947-4-1 are the standards to be referred to.

If I_c is the current to be broken by the contactor and I_e the rated operational current normally drawn by the load, then:

- Categories AC-1 and AC-3: $I_c = I_e$
- Category AC-2: $I_c = 2.5 \times I_e$
- Category AC-4: $I_c = 6 \times I_e$

Generally speaking $I_c = m \times I_e$ where m is a multiple of the load operational current.

On next pages, the curves corresponding to categories AC-1, AC-3, AC-2 and AC-4 represent the electrical durability variation of standard contactors in relation to the breaking current I_c .

Electrical durability is expressed in millions of operating cycles.

Curve utilization mode

Electrical durability forecast and contactor selection for categories AC-1, AC-2, AC-3 or AC-4

- Note the characteristics of the load to be controlled:
 - Operational voltage U_e
 - Current normally drawn I_e ($U_e / I_e / kW$ relation for motors, see "Motor rated operational powers and currents").
 - Utilization category AC-1, AC-2, AC-3 or AC-4
 - Breaking current $I_c = I_e$ for AC-1 and for AC-3 ; $I_c = 2.5 \times I_e$ for AC-2 ; $I_c = 6 \times I_e$ for AC-4
- Define the number of operating cycles N required.
- On the diagram corresponding to the operational category, select the contactor with the curve immediately above the intersection point ($I_c ; N$).

Electrical durability forecast and contactor selection for mixed duty motor control: AC-3 ($I_c = I_e$) type switching off while "motor running" and, occasionally, AC-4 ($I_c = 6 \times I_e$) type switching off while "motor accelerating"

- Note the characteristics of the motor to be controlled:
 - Operational voltage U_e
 - Current normally drawn while "motor running" I_e ($U_e / I_e / kW$ relation for motors, see "Motor rated operational powers and currents")
 - Breaking current for AC-3 $I_c = I_e$
 - Breaking current for AC-4 while "motor accelerating" $I_c = 6 \times I_e$
 - Percentage of AC-4 operating cycles K (on the basis of the total number of operating cycles)
- Define the total number of operating cycles N required.
- Note the smallest contactor rating compatible for AC-3 (U_e / I_e) on Main pole utilization characteristic table (see "Technical data").
- For the selected contactor make a note of the following in relation to the voltage using diagram AC-3 in next pages:
 - The number of operating cycles A for $I_c = I_e$ (AC-3)
 - The number of operating cycles B for $I_c = 6 \times I_e$ (AC-4)
- Calculate the estimated number of cycles N' (N' is always below A)

$$N' = \frac{A}{1 + 0.01 K (A/B - 1)}$$

- If N' is too low in relation to the target N , calculate the estimated number of cycles for a higher contactor rating.

Case of uninterrupted duty

For uninterrupted duty, some verifications of preventing maintenance are necessary to check the functionality of the concerned product (consult us).

The combined effect of environmental conditions and the proper temperature of the product may require some disposals. As a matter of fact, for this duty, the use duration prevails over the number of operating cycles.



R800 ... R2100 contactors

Electrical durability

Electrical durability for AC-1 utilization category - $U_e \leq 500 \text{ V}$

Switching non-inductive or slightly inductive loads. The breaking current I_c for AC-1 is equal to the rated operational current of the load.

Maximum electrical switching frequency: see "Technical data".

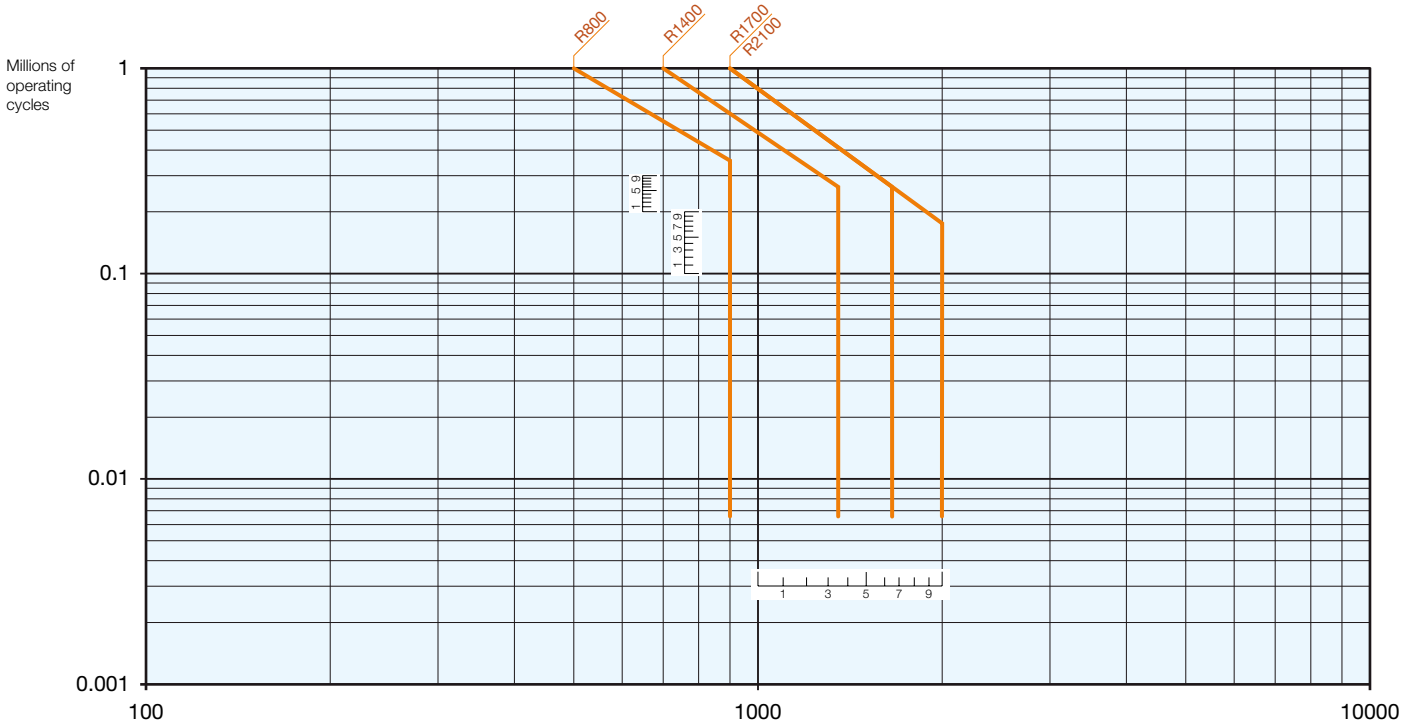

R800 ... R2100 contactors AC-1 electrical durability for $U_e \leq 500 \text{ V}$

R800 ... R2100 contactors

Electrical durability

Electrical durability for AC-2 or AC-4 utilization category

Switching cage motors: starting, reverse operation and step-by-step operation. The breaking current I_c is equal to $2.5 \times I_e$ for AC-2 and $6 \times I_e$ for AC-4, keeping in mind that I_e is the motor rated operational current (I_e = motor full-load current).

Maximum electrical switching frequency: see "Technical data".

AC-2 - $U_e \leq 500$ V

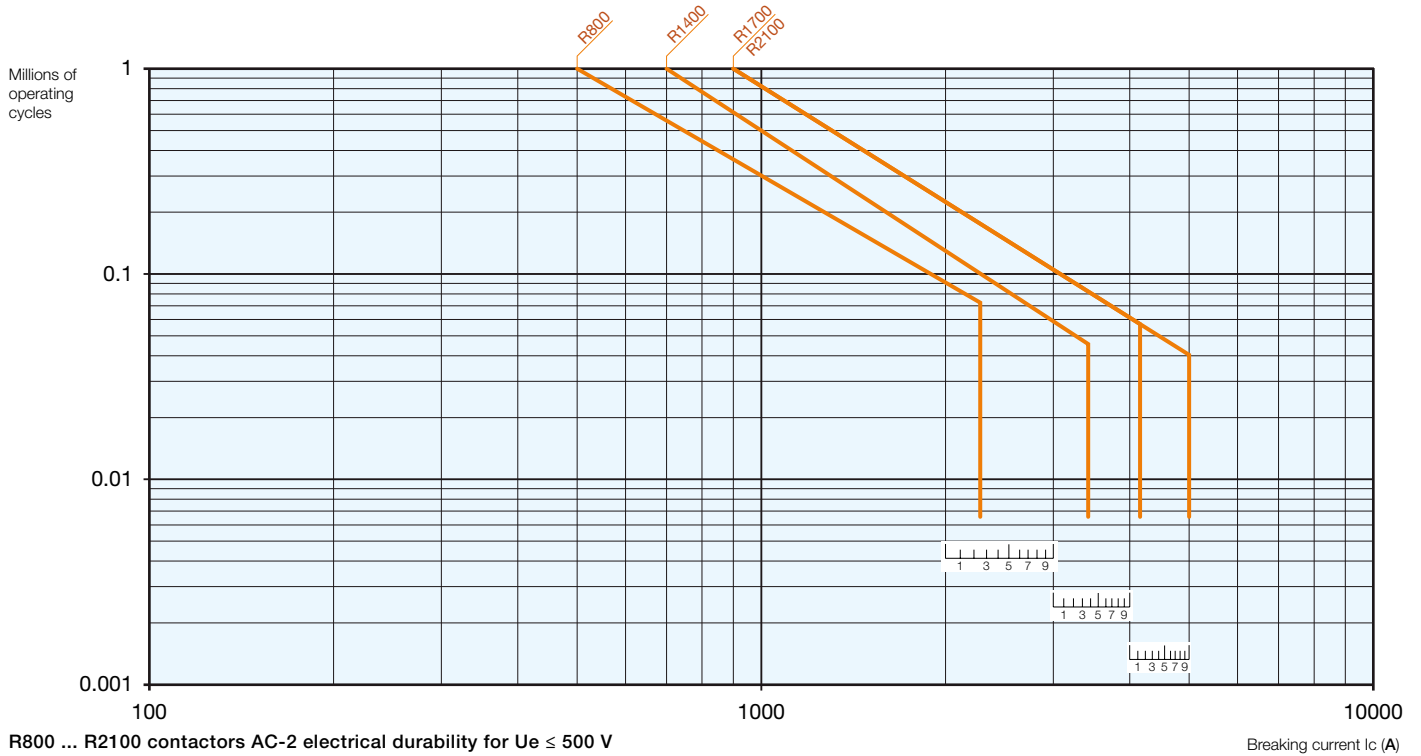

AC-4 - $U_e \leq 500$ V

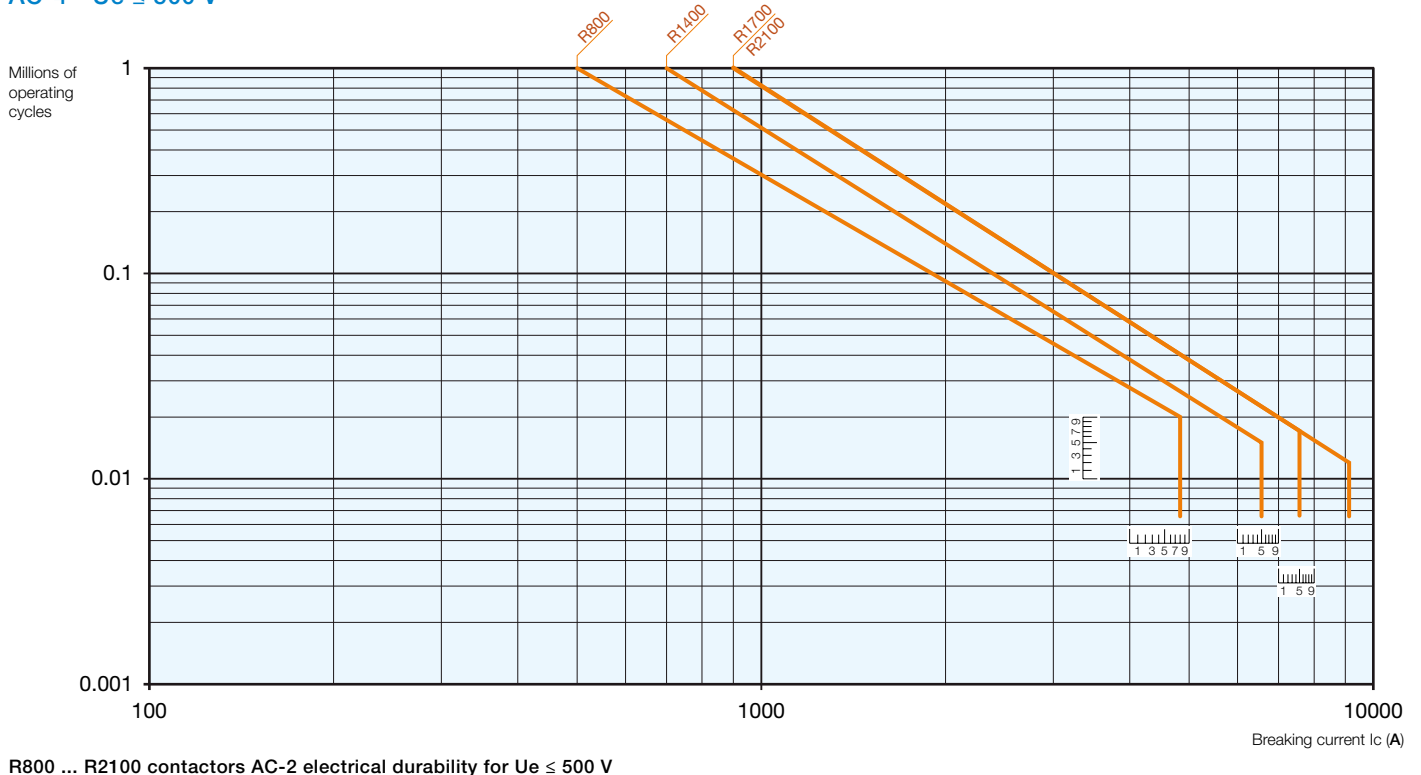

R63-MT ... R500-MT contactors

Electrical durability

Electrical durability for AC-3 utilization category

Switching cage motors: starting and switching off running motors. The breaking current I_c for AC-3 is equal to the rated operational current I_e (I_e = motor full load current). Maximum electrical switching frequency: see "Technical data".

AC-3 - $U_e \leq 690$ V

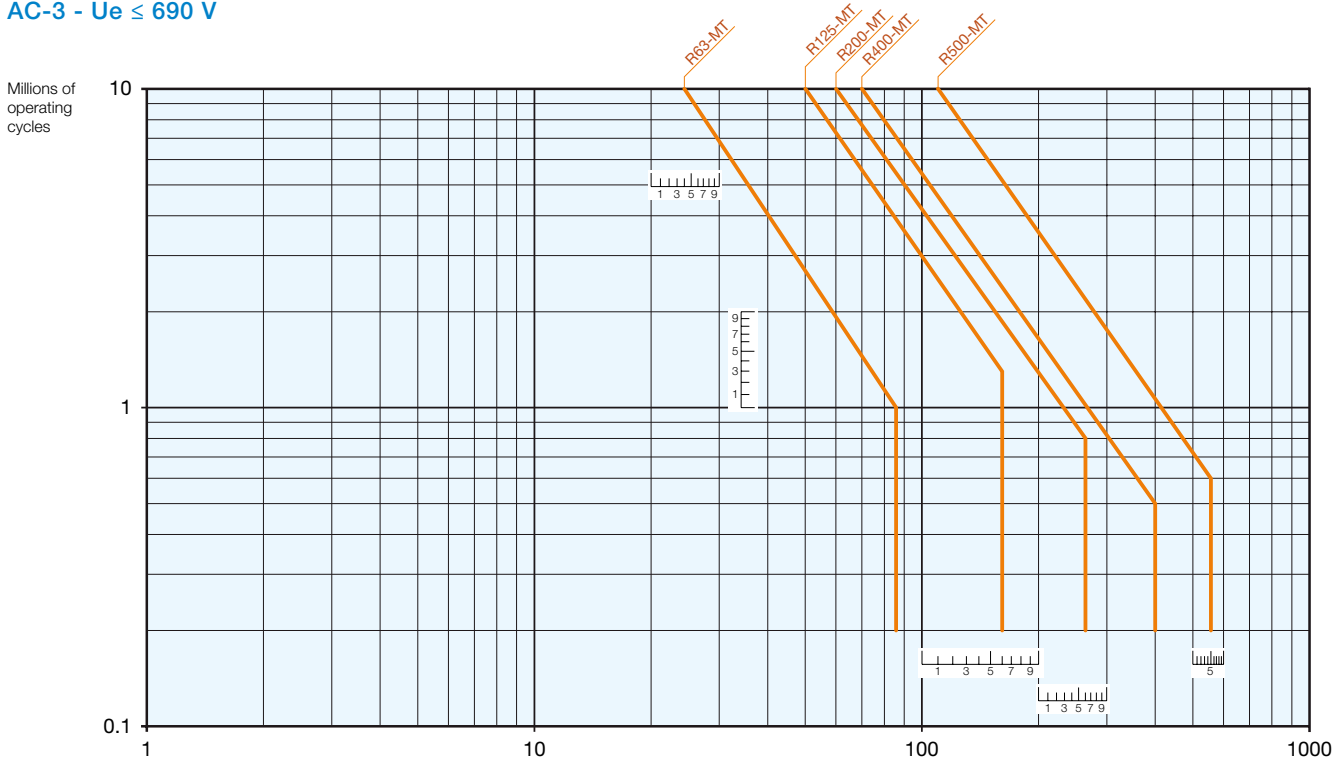

R63-MT ... R500-MT contactors AC-3 electrical durability for $U_e \leq 690$ V

Breaking current I_c (A)

AC-3 - 690 V $\leq U_e \leq 1000$ V

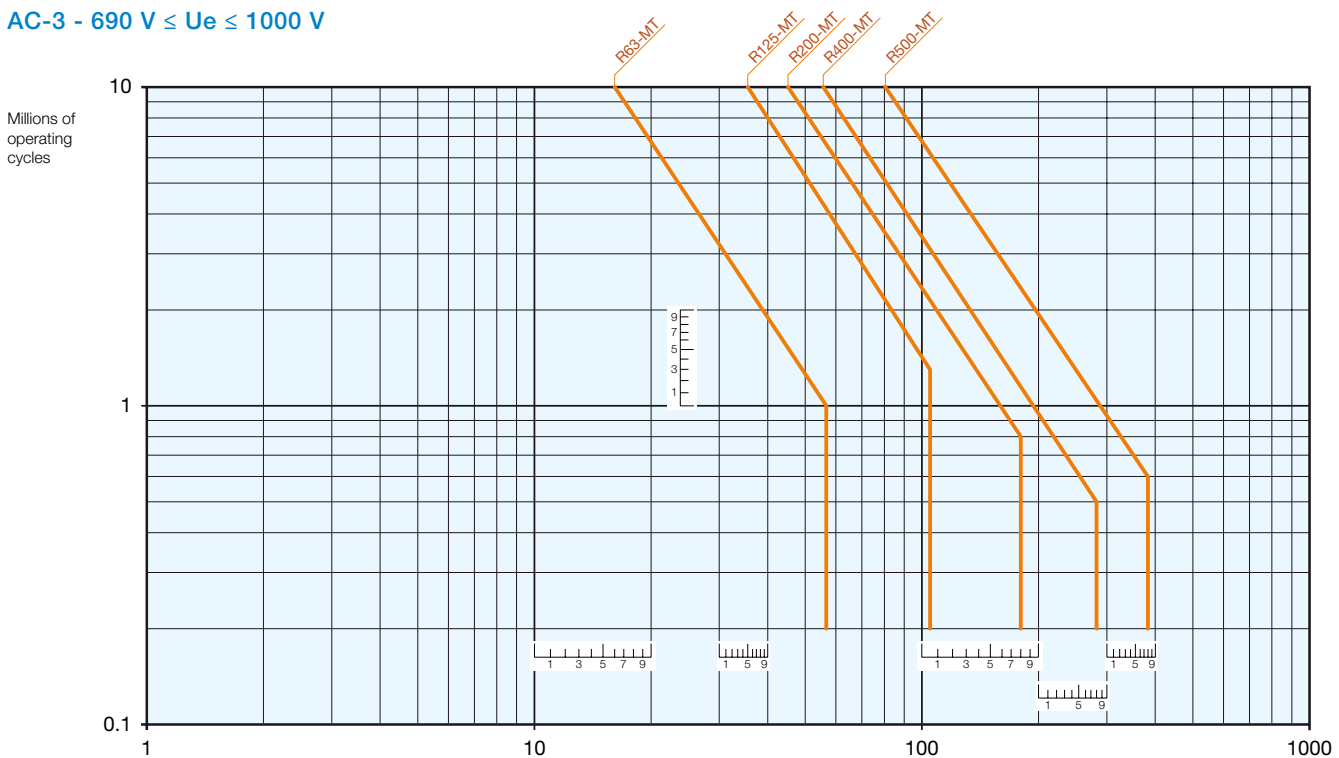

R63-MT ... R500-MT contactors AC-3 electrical durability for 690 V $\leq U_e \leq 1000$ V

Breaking current I_c (A)

R63-MT ... R500-MT contactors

Electrical durability

Electrical durability for AC-2 or AC-4 utilization category

Switching cage motors: starting, reverse operation and step-by-step operation. The breaking current I_c is equal to $2.5 \times I_e$ for AC-2 and $6 \times I_e$ for AC-4, keeping in mind that I_e is the motor rated operational current (I_e = motor full-load current).

Maximum electrical switching frequency: see "Technical data".

AC-2 - $U_e \leq 690$ V

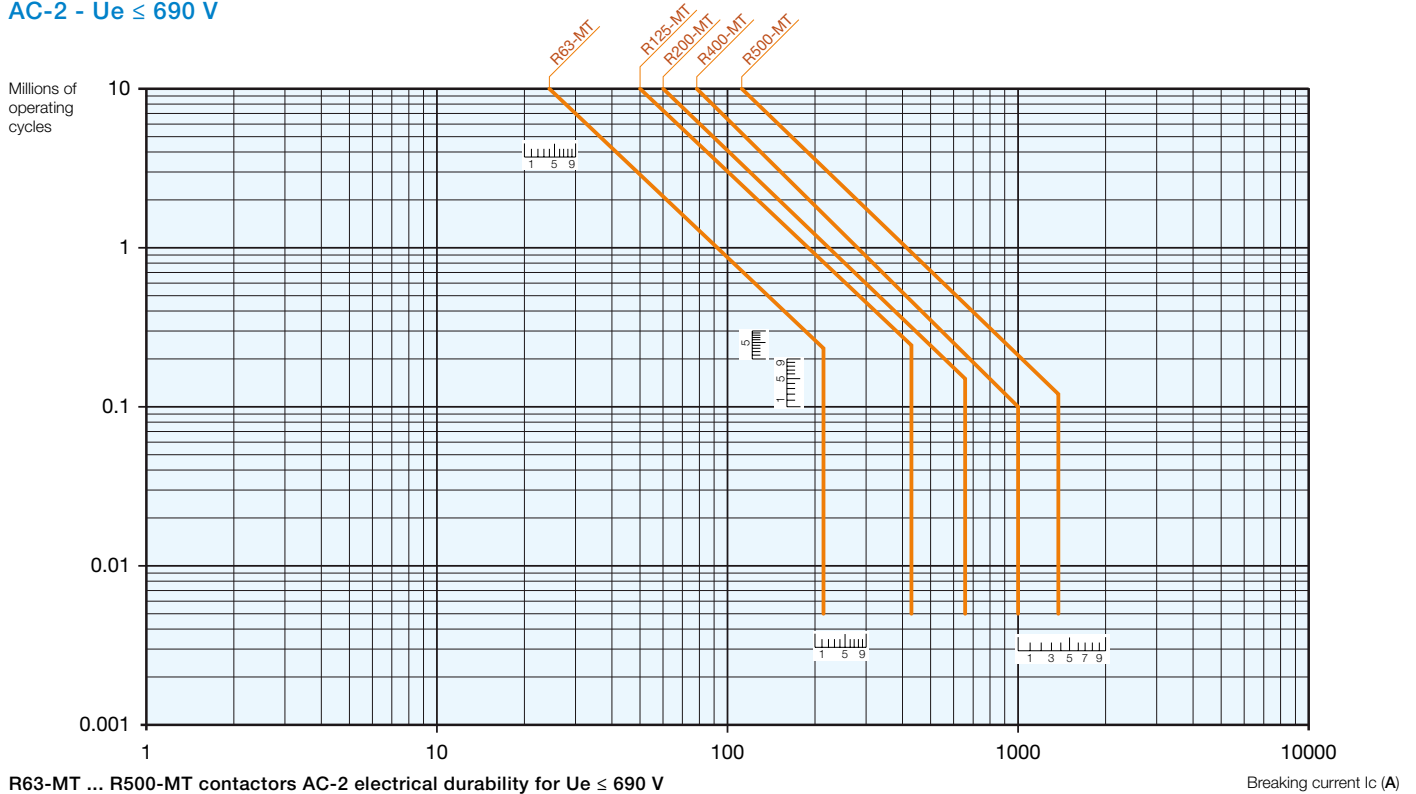

R63-MT ... R500-MT contactors AC-2 electrical durability for $U_e \leq 690$ V

Breaking current I_c (A)

AC-4 - $U_e \leq 690$ V

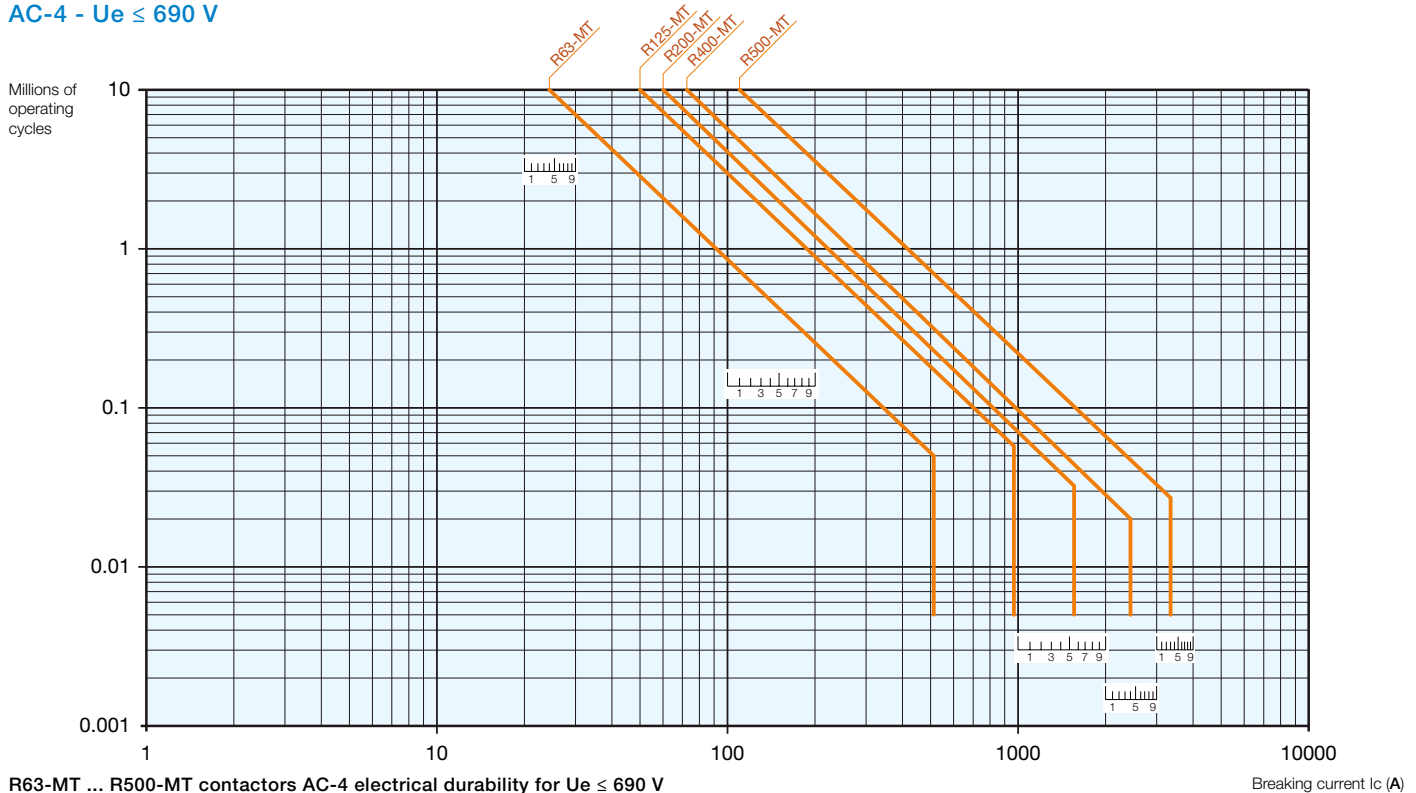

R63-MT ... R500-MT contactors AC-4 electrical durability for $U_e \leq 690$ V

Breaking current I_c (A)

R800-MT ... R2100-MT contactors

Electrical durability

Electrical durability for AC-1 utilization category - $U_e \leq 690\text{ V}$

Switching non-inductive or slightly inductive loads. The breaking current I_c for AC-1 is equal to the rated operational current of the load.

Maximum electrical switching frequency: see "Technical data".

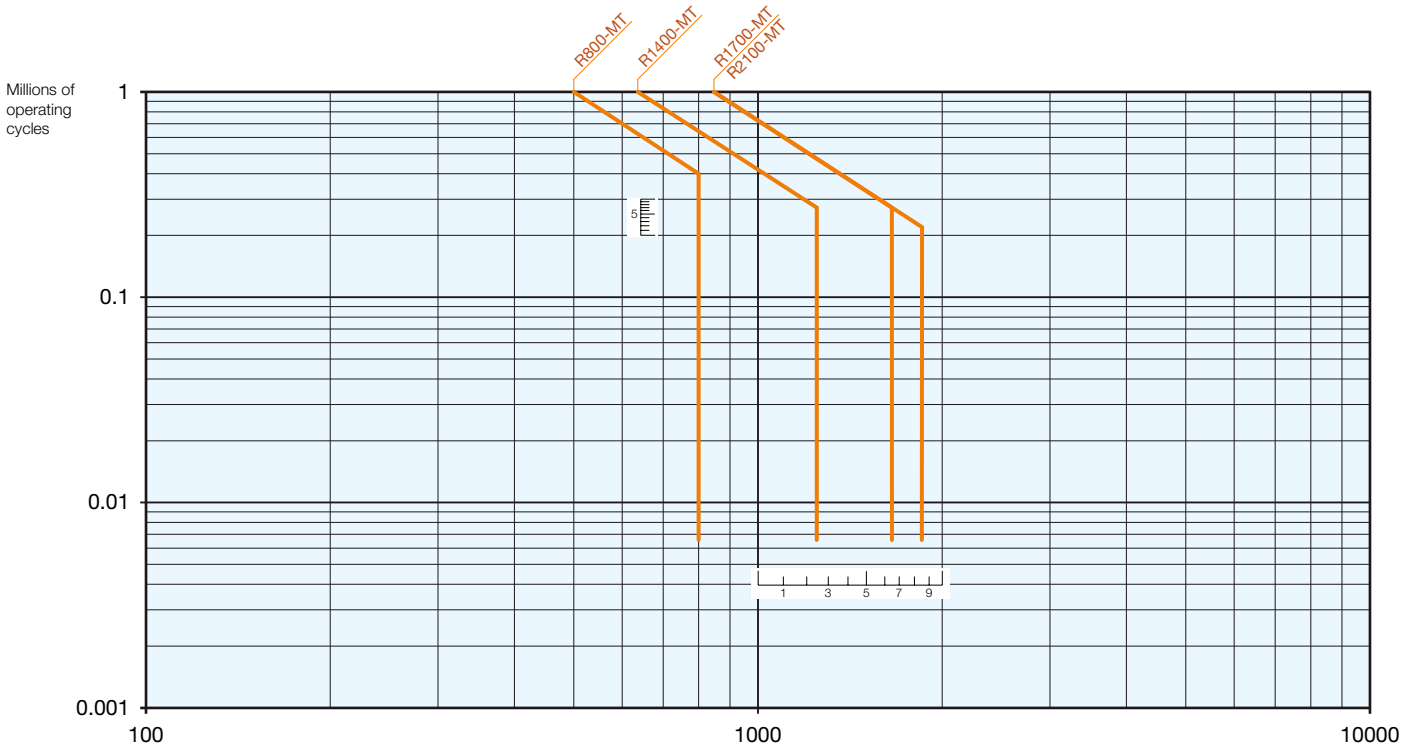

R800-MT ... R2100-MT contactors AC-1 electrical durability for $U_e \leq 690\text{ V}$

R800-MT ... R2100-MT contactors

Electrical durability

Electrical durability for AC-2 or AC-4 utilization category

Switching cage motors: starting, reverse operation and step-by-step operation. The breaking current I_c is equal to $2.5 \times I_e$ for AC-2 and $6 \times I_e$ for AC-4, keeping in mind that I_e is the motor rated operational current (I_e = motor full-load current).

Maximum electrical switching frequency: see "Technical data".

AC-2 - $U_e \leq 690$ V

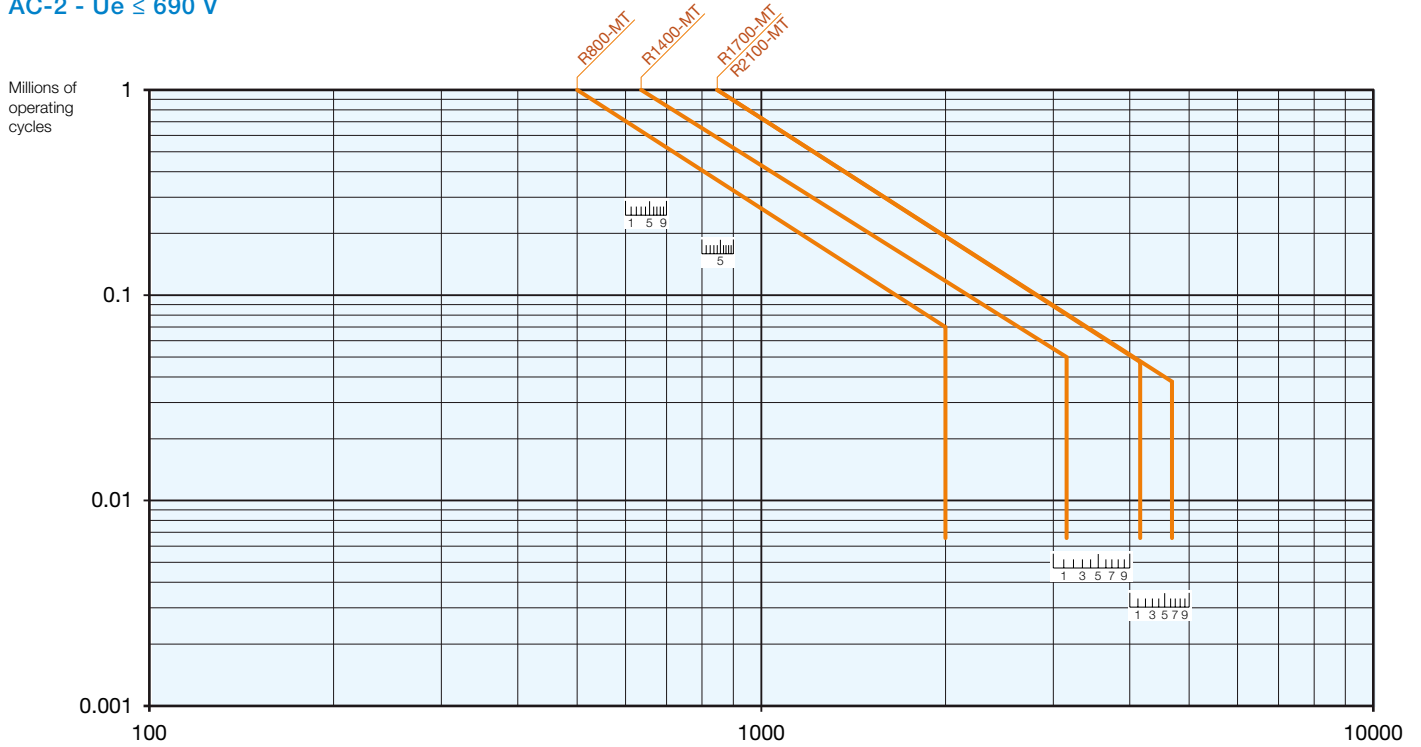

R800-MT ... R2100-MT contactors AC-2 electrical durability for $U_e \leq 690$ V

Breaking current I_c (A)

AC-4 - $U_e \leq 690$ V

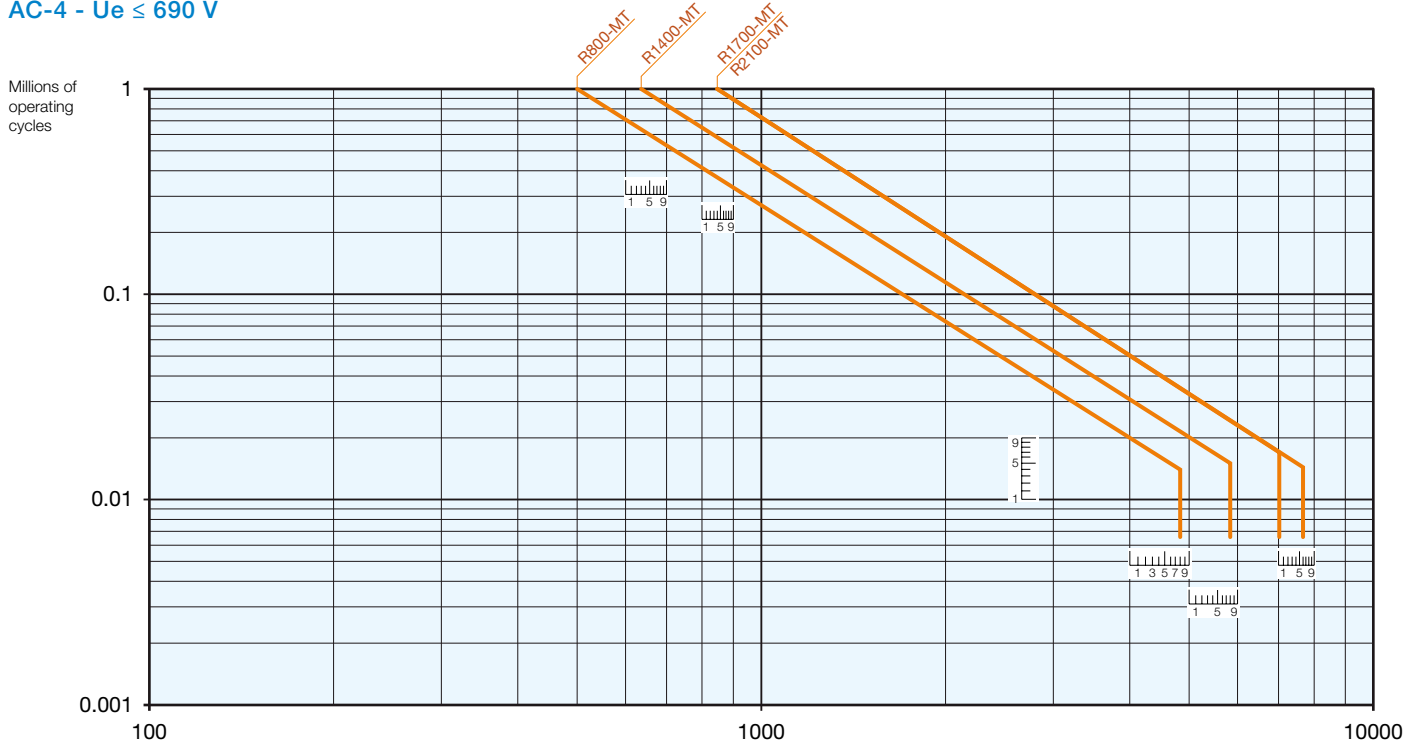

R800-MT ... R2100-MT contactors AC-2 electrical durability for $U_e \leq 690$ V

Breaking current I_c (A)



Accessories and spare parts

Auxiliary contacts

Auxiliary contact blocks CA12	7/2
Auxiliary contacts CA15	7/2
Technical data	7/3

Main poles

Contact sets	7/4
Arcing horns	7/4
Equipotential connections	7/5
Arc chutes	7/5

Control circuits

Surge suppressors	7/6
Rectifiers	7/6
Magnet circuits	7/6

Mechanical interlock units	7/7
-----------------------------------	------------

Mounting feet - Shaft extensions	7/8
---	------------



Auxiliary contacts



1SBC37983P0301

CA12-1

Auxiliary contact blocks type CA12

Description

CA12 auxiliary contact blocks 2 or 4-pole are mounted on a support bracket, above the electro-magnet.

The R contactors type R and RE can be equipped with:

- 1 or 2 x 2-pole blocks
- 1 x 2-pole block + 1 x 4-pole blocks.

The R contactors type RR can be equipped with 1 or 2 x 2-pole blocks.

Ordering details

For R contactors type R, RE, RR (RC excluded)	Auxiliary contacts	Type	Order code	Pkg qty	Weight (1 pce) kg
Auxiliary contact blocks					
63 ... 550	1 1	CA12-1	FPTN410004R0001	1	0.050
	2 0	CA12-2	FPTN410005R0001	1	0.050
	2 2	CA12-11	FPTN410013R0001	1	0.090
	3 1	CA12-12	FPTN410016R0001	1	0.090
	4 0	CA12-22	FPTN410012R0001	1	0.090
Support bracket					
63 ... 260		Support bracket	FPTN410056R0001	1	0.060
315 ... 550		Support bracket	FPTN410056R0002	1	0.060

7



1SBC104054F0014

CA15-F

Auxiliary contacts type CA15

Description

CA15 auxiliary contacts are mounted on a mounting kit, on the frame.

Ordering details

For R contactors type R, RE, RR, RC	Auxiliary contacts	Type	Order code	Pkg qty	Weight (1 pce) kg
Auxiliary contact with screw terminals					
63 ... 5100	1 0	CA15-F	FPTN410008R0004	1	0.070
	0 1	CA15-O	FPTN410007R0006	1	0.070
Auxiliary contact for railway					
63 ... 5100	1 0	CA15-F	FPTN210382R0003	1	0.070
	0 1	CA15-O	FPTN210382R0004	1	0.070
Mounting kit					
63 ... 170, 315 ... 550, auxiliary frame ≥ 800		Universal mounting kit	FPTN410054R0016	1	On request
200 ... 260		Mounting kit	FPTN410054R0017	1	
Main frame ≥ 800		Mounting kit	FPTN410213R0006	1	



1SBC104053F0014

CA15-O

Special auxiliary contact blocks

Please contact your local sales organization (order code of R contactor needed).

Auxiliary contact blocks

Technical data

CA auxiliary contact blocks

Types	CA12	CA15
Rated operational voltage Ue max.	690 V	
Rated frequency (without derating)	25...400 Hz	
Conventional free-air thermal current Ith acc. to IEC 60947-4-1, open couplers, $\theta \leq 40$ °C	12 A	15 A
le / Rated operational current AC-15 acc. to IEC 60947-5-1		
24-48 V 50/60 Hz	8 A	10 A
110-127 V 50/60 Hz	8 A	10 A
220-240 V 50/60 Hz	5 A	6 A
380-440 V 50/60 Hz	3 A	3.5 A
500-600 V 50/60 Hz	2 A	2.5 A
Making capacity acc. to IEC 60947-5-1	10 x Ie / AC-15	
Breaking capacity acc. to IEC 60947-5-1	10 x Ie / AC-15	
Ie / Rated operational current DC-13 acc. to IEC 60947-5-1		
24 V DC	6 A	
48 V DC	2.8 A	
72 V DC	1 A	
110-125 V DC	0.55 A	
220-250 V DC	0.3 A	
Short-circuit protection device gG type fuse	10 A	16 A



Main poles

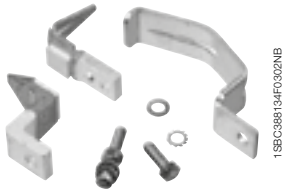

Contacts sets for N.O. or N.C. main poles

Description

The contact sets include 1 fixed contact, 1 moving contact, 1 arcing horn (according to table below) and screws.

The quantities needed are defined per ratings as follow:

- 1 set per pole for R63....R800, R1000, R1400, R1700, R2100
- 2 sets per pole for R1250, R1500, R2500, R3200, R3800
- 3 sets per pole for R2000, R4500, R5100
- 4 sets per pole for R3150
- 5 sets per pole for R4000.

Ordering details

For R contactors type		Order code	Pkg qty	Weight (1 pce) kg
Contact set with arcing horn				
IOR, NOR, JOR, FOR	63, 85	FPTN410389R0001	1 set	0.050
	125, 170	FPTN410389R0002	1 set	0.150
	200, 260	FPTN410389R0003	1 set	0.250
	315, 400 (1), 420	FPTN410389R0004	1 set	0.400
	400 (2), 500, 550, 630	FPTN410389R0005	1 set	0.480
Contact set without arcing horn				
LOR	85	FPTN410390R0001	1 set	0.040
	170	FPTN410390R0002	1 set	0.090
	260	FPTN410390R0003	1 set	0.180
	420	FPTN410390R0004	1 set	0.250
	400, 550	FPTN410390R0005	1 set	0.470
IOR, NOR, JOR, FOR, LOR	800, 1000, 1250, 1500, 2000, 3150, 4000	FPTN410391R0001	1 set	0.520
	1400, 2500	FPTN410503R0001	1 set	0.520
	1700, 2100, 3200, 3800, 4500, 5100	FPTN410506R0001	1 set	0.830

- (1) For NOR and JOR types, N.C. poles.
 (2) For IOR, NOR, JOR, N.O. poles.



Arcing horns for N.O. or N.C. main poles

Ordering details

For R contactors type IOR, NOR, JOR, FOR		Order code	Pkg qty	Weight (1 pce) kg
800, 1000, 1250, 1500, 2000, 3150, 4000		FPTN410446R0001	1	0.200
1400, 2500		FPTN410446R0001	1	0.200
1700, 2100, 3200, 3800, 4500, 5100		FPTN410508R0001	1	0.280

Main poles



Equipotential connections

Description

Equipotential connections must be ordered separately for ratings ≥ 800 A.

Ordering details

For R contactors type IOR, NOR, JOR and FOR	Type	Order code	Pkg qty	Weight (1 pce) kg
800 ... 5100	NO poles	FPTN410176R0006	1	0.500
800 ... 4000	NC poles	FPTN410176R0007	1	0.530

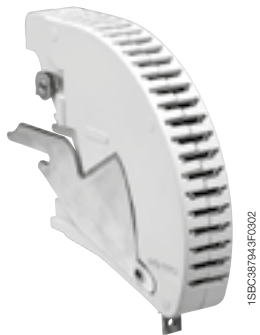

Arc chutes

Description

De-ion arc chutes replace basic arc chutes except for 315 and 420 A ratings.

Ordering details

For R contactors type IOR, NOR, JOR and FOR	Type	Order code	Pkg qty	Weight (1 pce) kg
63, 85	De-ion arc chute	FPTN401938R0002	1	0.470
125, 170	De-ion arc chute	FPTN401939R0002	1	0.930
200, 260	De-ion arc chute	FPTN401940R0002	1	1.360
315, 400 (1), 420	Basic arc chute	FPTN401936R0002	1	1.300
400 (2), 500, 550	De-ion arc chute	FPTN401941R0002	1	3.600
800, 1000, 1250, 1500, 2000, 3150, 4000	De-ion arc chute	FPTN410067R0002	1	2.570
1400, 2500	De-ion arc chute	FPTN410067R0002	1	2.570
1700, 2100, 3200, 3800, 4500, 5100	De-ion arc chute	FPTN410507R0001	1	3.150

(1) For NOR and JOR types, N.C. poles.

(2) For IOR, NOR, JOR types, N.O. poles.

Pressure springs, insulated supports, complete poles and other spare parts

Please contact your local sales organisation (order code for R contactor needed).

Control circuits



1SBC10403RF0014

Surge suppressors for contactor coils

Ordering details

For R contactors type IOR, NOR, JOR, LOR and FOR	Rated control circuit voltage Uc		Type	Order code	Pkg qty	Weight (1 pce) kg
	V	AC DC				
63 ... 5100	24...60	● -	RV-R1/60	FPTN410463R6001	1	0.050
	60...133	● -	RV-R1/133	FPTN410463R6002	1	0.050
	110...250	● -	RV-R1/250	FPTN410463R6003	1	0.050
	250...440	● -	RV-R1/440	FPTN410463R6004	1	0.050
	440...660	● -	RV-R1/660	FPTN410463R6005	1	0.050
	24...90	- ●	RV-R1/60	FPTN410463R6001	1	0.050
	60...180	- ●	RV-R1/133	FPTN410463R6002	1	0.050
	110...320	- ●	RV-R1/250	FPTN410463R6003	1	0.050
	250...550	- ●	RV-R1/440	FPTN410463R6004	1	0.050
	440...660	- ●	RV-R1/660	FPTN410463R6005	1	0.050



1SBC10403RF0014

Rectifiers

Ordering details

For R contactors type IORR, NORR, JORR, LORR and FORR	Rated control circuit voltage Uc	Order code	Pkg qty	Weight (1 pce) kg
63 ... 5100	< 440 V AC	TRE2614501	1	0.050
	≥ 440 V AC	TRE2720801	1	0.050

Complete control circuit kit

Including:

- 1 coil
- 1 economy resistor
- 1 surge suppressor
- 1 rectifier.

For complete kit, please contact your local sales organization (order code of R contactor needed).

Magnet circuits

Ordering details

For R contactors type IORR, NORR, JORR, LORR, and FORR IORE, NORE, JORE, LORE, and FORE	Order code	Pkg qty	Weight (1 pce) kg
63, 85	FPTN410437R0001	1	1.500
125, 170	FPTN410438R0001	1	1.500
200, 260	FPTN410439R0001	1	1.500
400 ... 630	FPTN410441R0001	1	2.500
≥ 800	FPTN410200R0006	1	8.000

For tripping electro-magnet circuit AME or AM(F)-CC > 800 A: use 63, 85 A electro-magnet circuit.

For IOR and IOR..AMA versions, please consult your local sales organization (order code of R contactor needed).

Coils, economy resistors and other specific parts

Please contact your local sales organization (order code of R contactor needed).

Mechanical interlock units



VM

1SBC388162F0002

Description

The VM mechanical interlock units are designed for the interlocking of two R contactors of the same rating. The mounting between 2 contactors of a same rating doesn't affect their fixing centres or their overall dimensions.

Ordering details

For R contactors type IOR, NOR, JOR, LOR and FOR	Rating	Fixing center mm	Type	Order code	Pkg qty	Weight (1 pce) kg
IOR...-CC, IOR...-MT, NOR...-CC, NOR...-MT, LOR...	63	220	VM21/24	FPL7101403R0001	1	0.140
	125	260	VM25	FPL7401404R0001	1	0.180
	200	320	VM27	FPL8001401R0001	1	0.260
IOR...-CC, IOR...-MT, NOR...400, LOR...	400 ... 500	520	VM15-SP	FPL8301401R0002	1	0.500
IOR..., LOR...800, NOR...800, FOR...1000	800 ... 1000	520	VM16	FPL8601401R0001	1	0.600
IOR...-CC, IOR...-MT	800 ... 1000	640	VM17/18	FPL8801401R0001	1	0.700
IOR..., LOR..., FOR...	1400, 1700, 2100	640				
IOR...-CC, IOR...-MT	1400, 1700, 2100	680	VM19	FPL9001401R0001	1	0.800

Note: For special versions, please consult us:

- interlocking between contactors with N.O. + N.C. poles or with latching
- interlocking between 2 contactors of different ratings
- interlocking between 3 contactors.



Mounting feet - Shaft extensions



4NMW1009/1039

1SECT04030F0014



4NMW1041

1SECT04028F0014

Mounting feet

Description

When the contactors are to be fitted on a back plate the mounting feet provide an increased clearance behind the contactor for easier cabling.

Two pieces are required for one contactor.

Ordering details

For R contactors	Drilling for bar fixing Ø mm	Fixing centres for vertical wall mounting mm	Type	Order code	Pkg qty	Weight (2 pce) kg
63 ... 170	6.2	85 / 100...110	4NMW1009	FPL7108201P0001	2	0.060
200, 260	8.2	85 / 100...110	4NMW1039	FPL7608201P0001	2	0.060
400, 500, 550	12.5	110...120	4NMW1041	FPL8308201P0001	2	0.320

Main dimensions mm

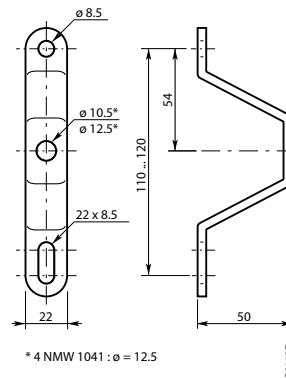
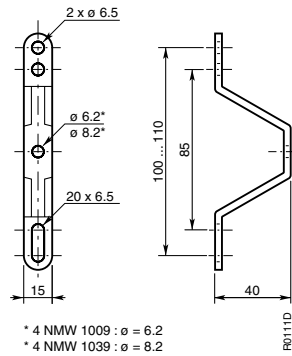

7

Shaft extensions

Description

For 3 or 4 pole reversing or changeover pairs built with two contactors of different ratings, vertically mounted above one another. Fitting on the shaft of the contactor having the smaller frame size.

Ordering details

For R contactors	Type	Order code	Pkg qty	Weight (1 pce) kg
63 ... 170	-	FPTN410111R0001	1	(1)
200 ... 420	-	FPTN410111R0002	1	(1)
400, 500, 550	-	FPTN410111R0003	1	(1)

(1) On request.

Notes

Area with horizontal dotted lines for writing notes.





Terminal marking and wiring diagrams

Terminal marking and positioning

R63 ... R500	8/2
R800 ... R5100	8/3

Wiring diagrams

R contactors and couplers

Control by 2 impulse pushbuttons and hold-in contact	8/4
Control by switch	8/4

R magnetically latched contactors - Contactors and couplers

Control by 2 impulse pushbuttons	8/5
Control by switch	8/6

Alternator field discharge

With magnetical latching	8/7
With mechanical latching	8/8



IORR, IORE, NORR, NORE, LORR, LORE, FORR and FORE types

Terminal marking and positioning

R63 ... R500 (the main poles in variable number)

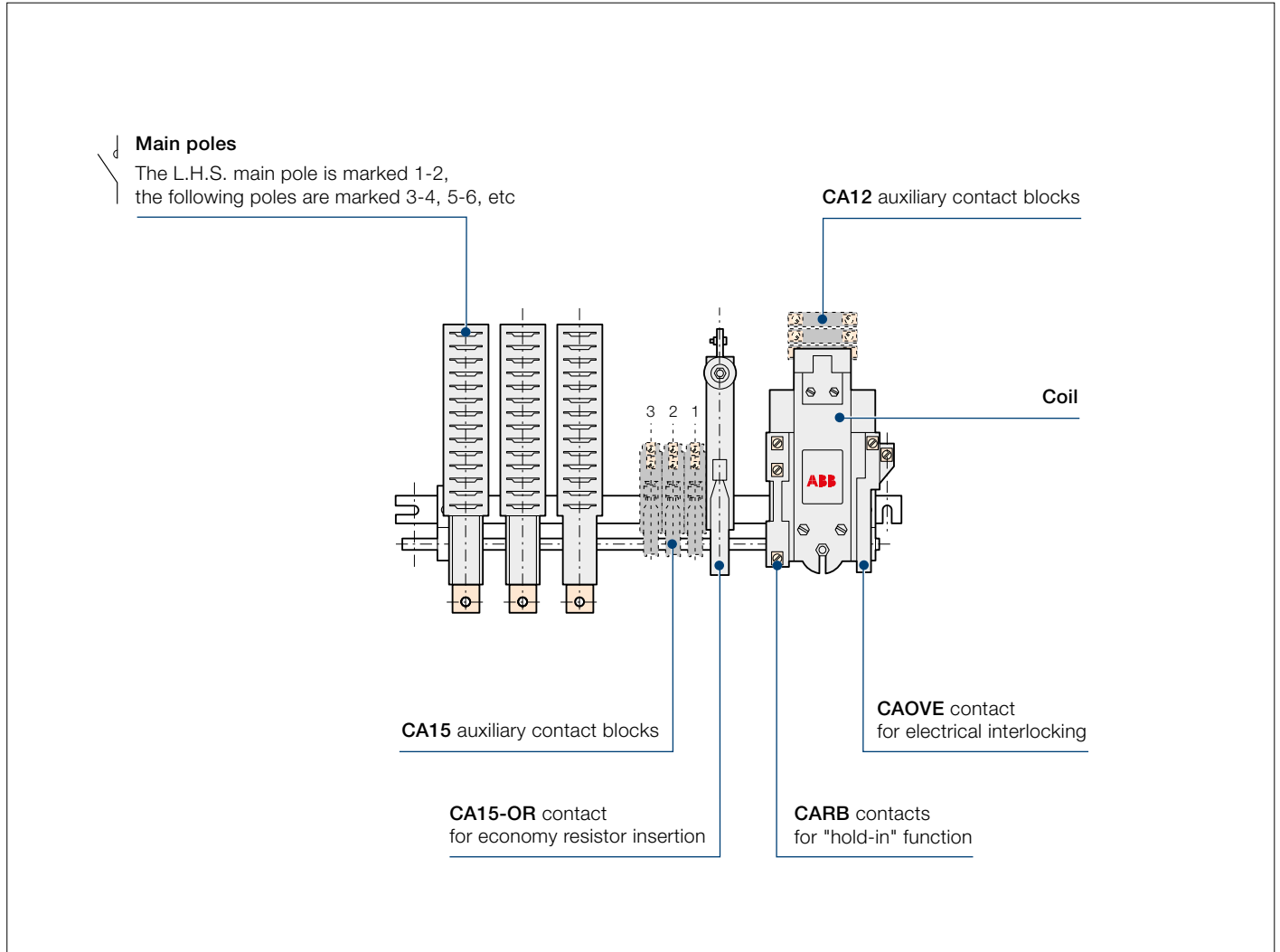

Main poles	N.O. main poles are respectively marked 1-2, 3-4, 5-6, 7-8 For N.C. main poles the letter R precedes the figures								
Coil	AC coil: the terminals are marked A1 and A2 DC coil: the terminals are marked A1 (-) and A2 (+)								
CAOVE contact	N.C. contact, adjustable, intended for electrical interlocking. Terminal marking: 21-22								
CARB contact	N.O. contact, intended for "hold-in" function. Terminal marking: 13-14								
CA15-OR contact	N.C. contact, factory wired. It is intended for insertion of economy resistor. Terminal marking: 15-16								
CA12 auxiliary contacts	1 NO + 1 NC	2 NO	2 NO + 2 NC	3 NO + 1 NC	4 NO	3 NO + 3 NC	4 NO + 2 NC	5 NO + 1 NC	6 NO
Block No 3						83 71 84 72	83 73 84 74	83 73 84 74	83 73 84 74
Block No 2			63 51 64 52	63 53 64 54	63 53 64 54	63 51 64 52	63 51 64 52	63 53 64 54	63 53 64 54
Block No 1	43 31 44 32	43 33 44 34	43 31 44 32	43 31 44 32	43 33 44 34	43 31 44 32	43 31 44 32	43 31 44 32	43 33 44 34
CA15 extra auxiliary contacts	No "n"	No 8	No 7	No 6	No 5	No 4	No 3	No 2	No 1
CA15-F (N.O.)	.3 .4	173 174	163 164	153 154	143 144	133 134	123 124	113 114	103 104
or CA15-O (N.C.)	.1 .2	171 172	161 162	151 152	141 142	131 132	121 122	111 112	101 102

The CA15 auxiliary contacts are fitted from the right on the contactor frame according to this marking.

IORR, IORE, NORR, NORE, LORR, LORE, FORR and FORE types

Terminal marking and positioning

R800 ... R5100 (the main poles in variable number, can be distributed on both sides of the electro-magnet)

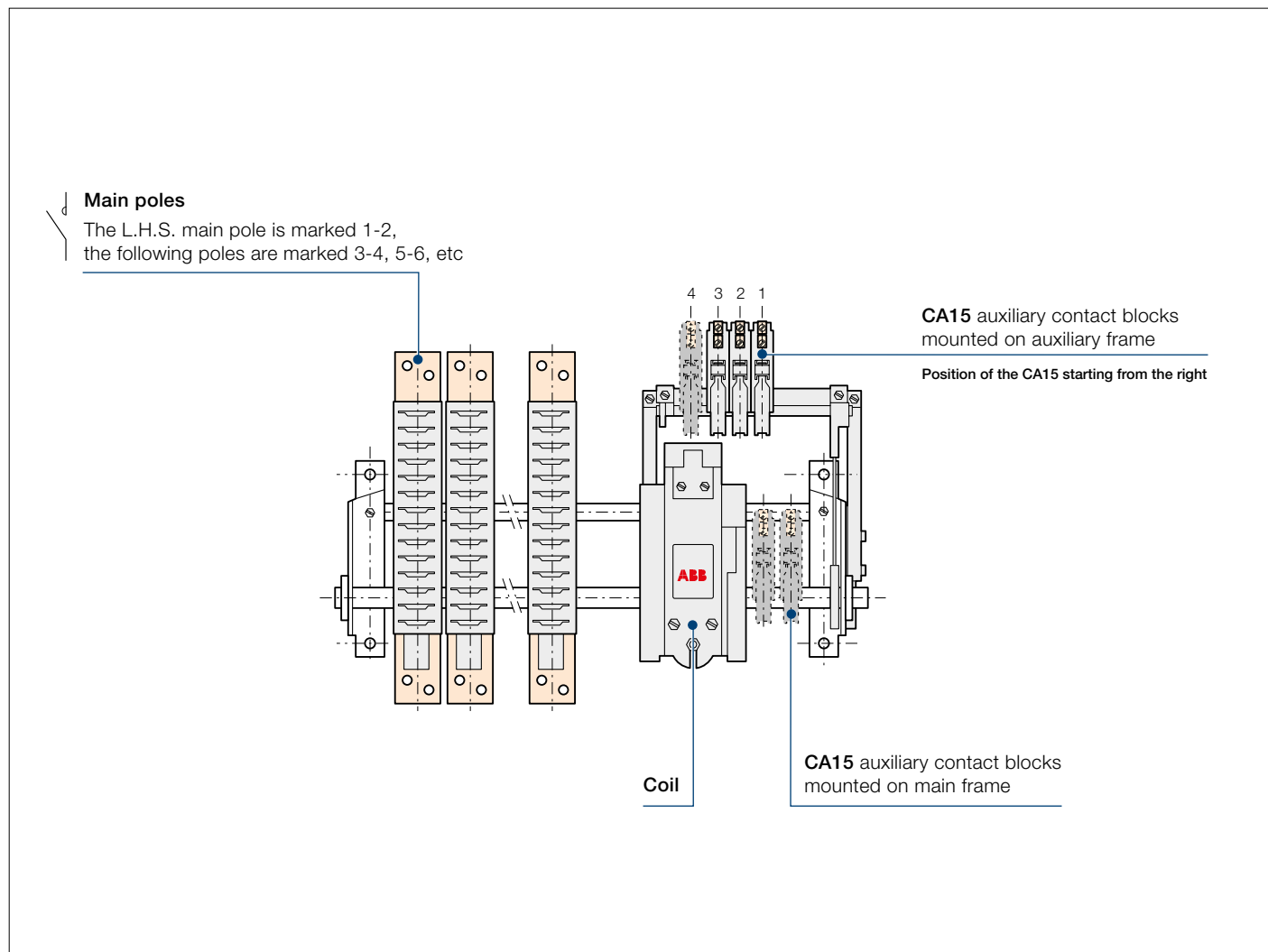

Main poles	N.O. main poles are respectively marked 1-2, 3-4, 5-6, 7-8 For N.C. main poles the letter R precedes the figures								
Coil	AC coil: the terminals are marked A1 and A2 DC coil: the terminals are marked A1 (-) and A2 (+)								
CA15 auxiliary contact	No 1	CA15-O (N.C.) contact intended for electrical interlocking. Terminal marking: 21-22							
	No 2	CA15-F (N.O.) contact intended for "hold-in" function. Terminal marking: 13-14							
	No 3	CA15-OR (N.C.). This contact is factory wired. It is intended for insertion of economy resistor. Terminal marking: 15-16							
CA15 extra auxiliary contacts	No "n"	No 11	No 10	No 9	No 8	No 7	No 6	No 5	No 4
	CA15-F (N.O.)	..3 ..4	173 174	163 164	153 154	143 144	133 134	123 124	113 114
or CA15-O (N.C.)	..1 ..2	171 172	161 162	151 152	141 142	131 132	121 122	111 112	101 102

The CA15 auxiliary contacts are fitted from the right, first on the auxiliary frame and next on the main frame of the contactor, according to this marking.

R contactors and couplers

Wiring diagrams

Control by 2 impulse pushbuttons and hold-in contact

AC operated

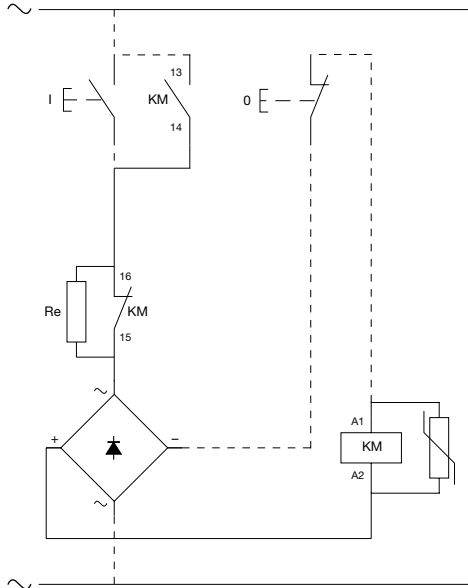

IORR, IORR-MT, IORR-CC, NORR-MT, NORR-CC, LORR

DC operated

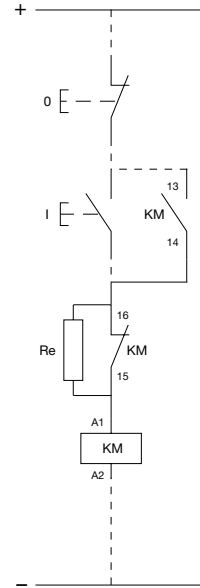

IORE, IORE-MT, IORE-CC, NORE-MT, NORE-CC, LORE

8

Control by switch

AC operated

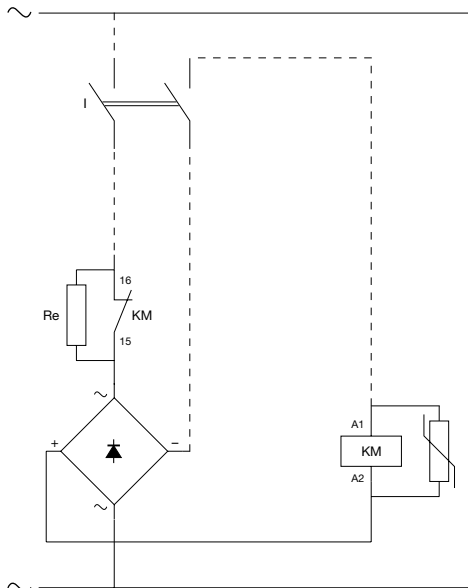

IORR, IORR-MT, IORR-CC, NORR-MT, NORR-CC, LORR

Note: remove the factory wired strap 14-16

DC operated

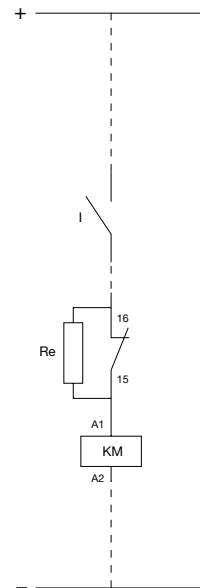

IORE, IORE-MT, IORE-CC, NORE-MT, NORE-CC, LORE

Note : remove the factory wired strap 14-16

R magnetically latched contactors

Contactors and couplers

Wiring diagrams

Control by 2 impulse pushbuttons

AC operated

Control voltage $U_c \leq 110$ V AC

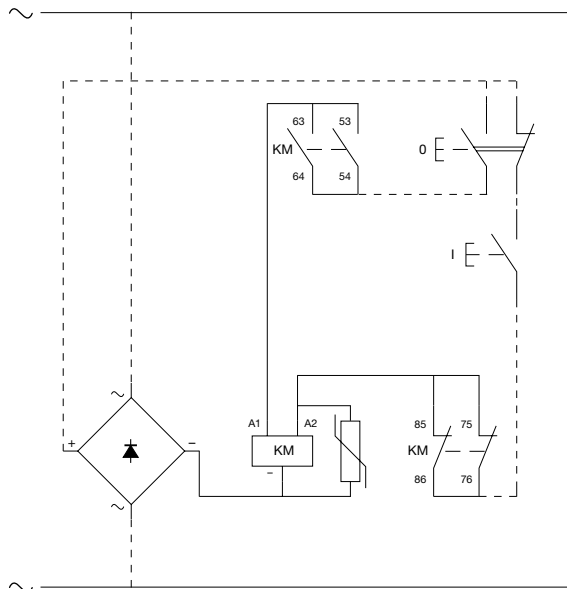

IORR-CC-AMA, IORR-MT-AMA, NORR-CC-AMA,
NORR-MT-AMA, LORR-AMA

AC operated

Control voltage $U_c > 110$ V AC

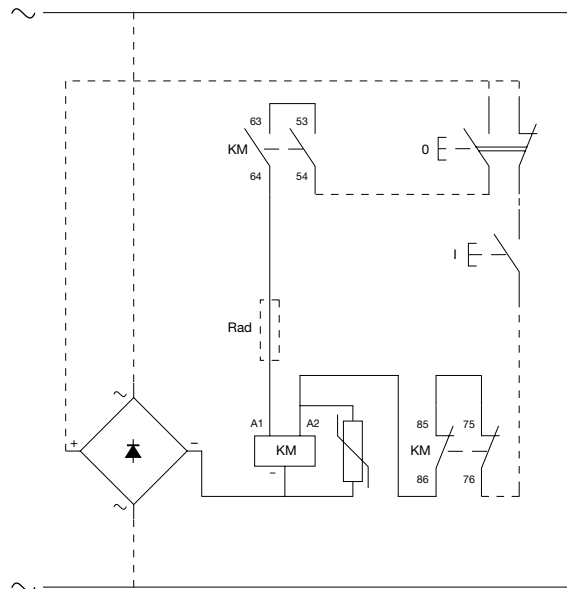

IORR-CC-AMA, IORR-MT-AMA, NORR-CC-AMA,
NORR-MT-AMA, LORR-AMA

8

DC operated

Control voltage $U_c \leq 110$ V AC

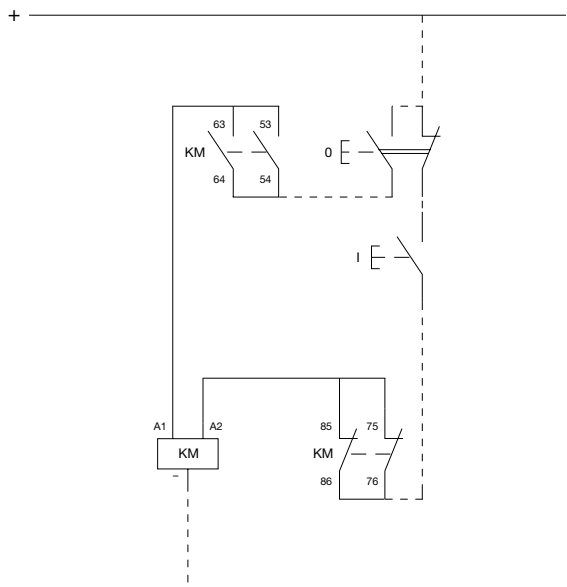

IOR-CC-AMA, IOR-MT-AMA, NOR-CC-AMA,
NOR-MT-AMA, LOR-AMA

DC operated

Control voltage $U_c > 110$ V AC

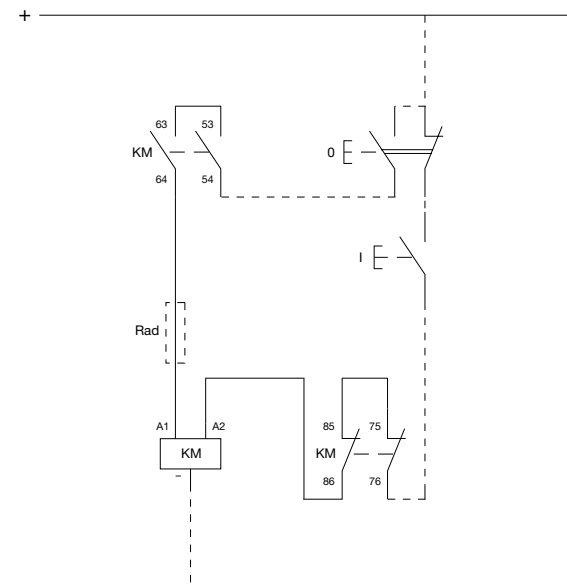

IOR-CC-AMA, IOR-MT-AMA, NOR-CC-AMA,
NOR-MT-AMA, LOR-AMA

R mechanically latched contactors

Contactors and couplers

Wiring diagrams

Control by switch

AC operated

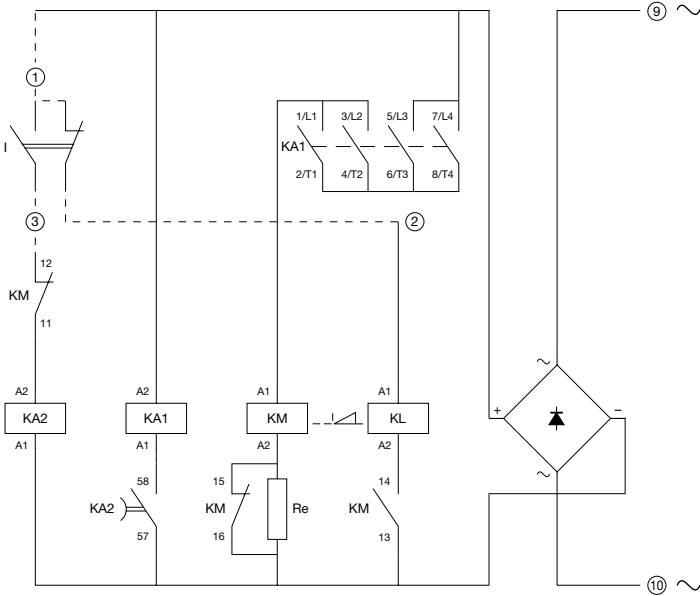

KM = Closing coil
KL = Tripping coil
KA1 = Contactor relay
KA2 = Timed contactor relay
Re = Economy resistor

Supply between ⑨ and ⑩
 Closing between ① and ③
 Tripping between ① and ②

8

IORR-AME, IORR-MT-AME, IORR-CC-AME, NORR-CC-AME, NORR-MT-AME, LORR-AME



DC operated

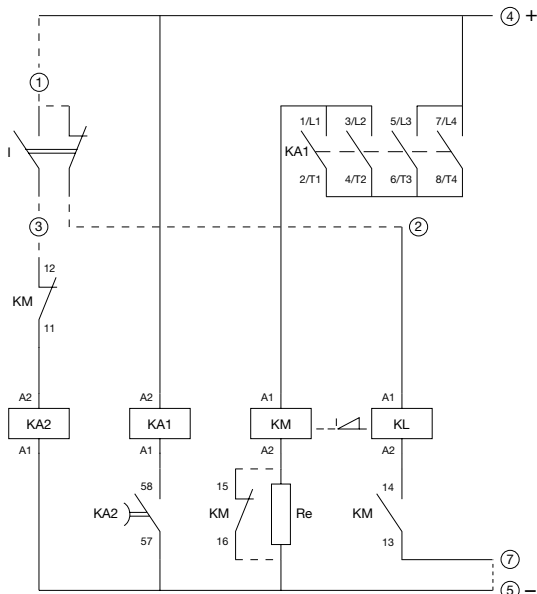

KM = Closing coil
KL = Tripping coil
KA1 = Contactor relay
KA2 = Timed contactor relay
Re = Economy resistor

Supply between ④ and ⑤
 Closing between ① and ③
 Tripping between ① and ②

If the closing coil voltage and the tripping coil voltage are different remove the strap between terminals ⑤ and ⑦.

IORE-AME, IORE-MT-AME, IORE-CC-AME, NORE-CC-AME, NORE-MT-AME, LORE-AME

Alternator field discharge with magnetical latching

Wiring diagrams

Control by 2 impulse pushbuttons

DC operated

Control voltage $U_c \leq 110$ V AC

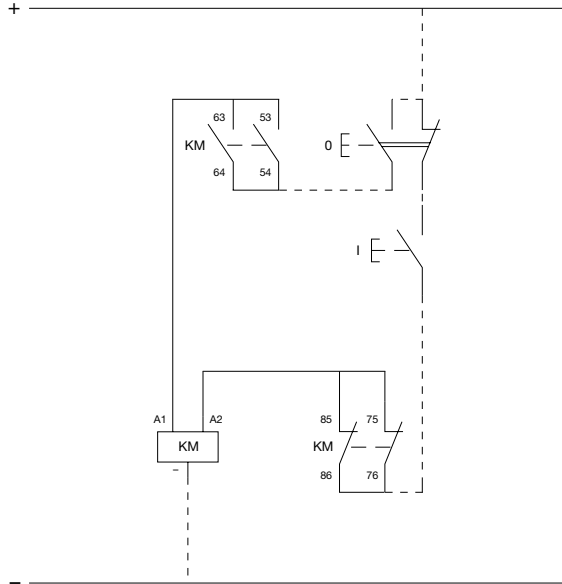

AM-CC-NOR63-21 ... AM-CC-NOR200-21
AM-CC-NOR63-31 ... AM-CC-NOR200-31

DC operated

Control voltage $U_c > 110$ V AC

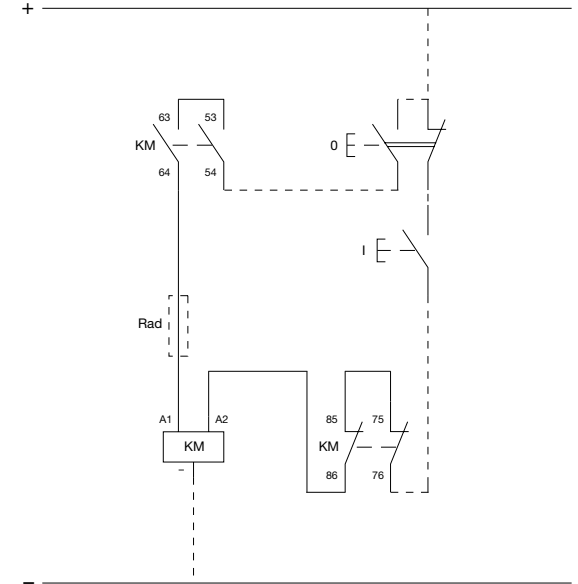

AM-CC-NOR63-21 ... AM-CC-NOR200-21
AM-CC-NOR63-31 ... AM-CC-NOR200-31



Alternator field discharge with mechanical latching

Wiring diagrams

DC operated

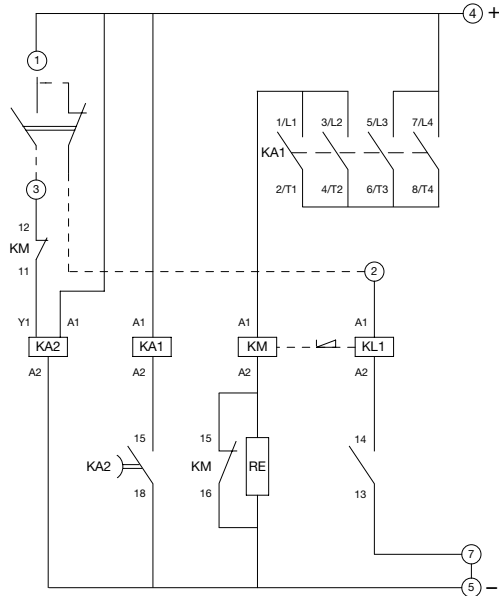

KM = Closing coil
KL1 = Tripping coil
KA1 = Contactor relay
KA2 = Timed contactor relay
RE = Economy resistor

Supply between ④ and ⑤
 Closing between ① and ③
 Tripping KL1 between ① and ②

If the closing coil voltage and the tripping coil voltage are different, remove the strap between ⑤ and ⑦.

AM-CC-JORE550-21 ... AM-CC-JORE2100-21
 AM-CC-JORE550-31 ... AM-CC-JORE2100-31

8

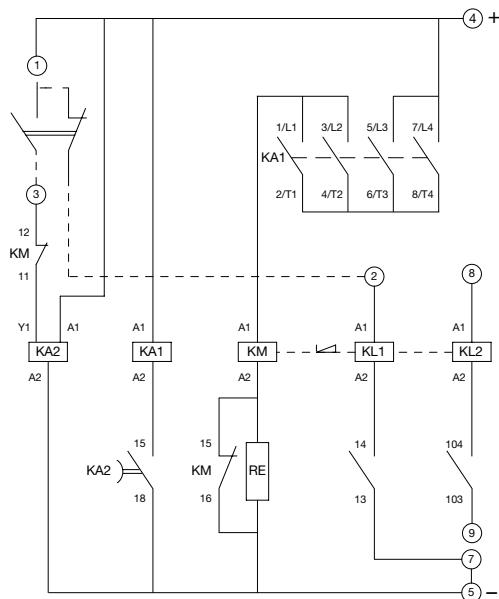

KM = Closing coil
KL1 = Tripping coil
KL2 = Tripping coil
KA1 = Contactor relay
KA2 = Timed contactor relay
RE = Economy resistor

Supply between ④ and ⑤
 Closing between ① and ③
 Tripping KL1 between ① and ②
 Tripping KL2 between ⑧ and ⑨

If the closing coil voltage and the tripping coil voltage are different, remove the strap between ⑤ and ⑦.

AMF-CC-JORE550-21 ... AMF-CC-JORE2100-21
 AMF-CC-JORE550-31 ... AMF-CC-JORE2100-31

Notes

Lined area for notes, consisting of numerous horizontal blue dotted lines.





Main dimensions

IORR ... IORE and LORR ... LORE types

R800 ... R2100	9/2
R2500 ... R5100	9/4

IORR..MT ... IORE..MT and IORR..CC ... IORE..CC types

R63 ... R500	9/6
R800 ... R2100	9/8
R2500 ... R5100	9/10

IORR..AME ... IORE..AME and LORR..AME ... LORE..AME types

R800 ... R2100	9/12
R2500 ... R5100	9/14

IORR..MT-AMA ... IOR..MT-AMA and IORR..CC-AMA ... IOR..CC-AMA types

R63 ... R200	9/16
--------------	------

IORR..MT-AME ... IORE..MT-AME and IORR..CC-AME ... IORE..CC-AME types

R400 ... R500	9/18
R800 ... R2100	9/20
R2500 ... R5100	9/22

NORR..MT ... NORE..MT and NORR..CC ... NORE..CC types

R63 ... R200	9/24
--------------	------

LORR and LORE types

R85 ... R550	9/26
--------------	------

AM-CC-NOR types

R63 ... R200	9/28
--------------	------

AM-CC-JORE and AMF-CC-JORE types

R550	9/30
------	------

AM-CC-JORE types

R800 ... R2100	9/32
----------------	------

AMF-CC-JORE types

R800 ... R2100	9/34
----------------	------

AM-CC-JORE types

R2500 ... R4500	9/36
-----------------	------

AMF-CC-JORE types

R2500 ... R4500	9/38
-----------------	------



IORR ... IORE and LORR ... LORE types R800 ... R2100

Main dimensions mm

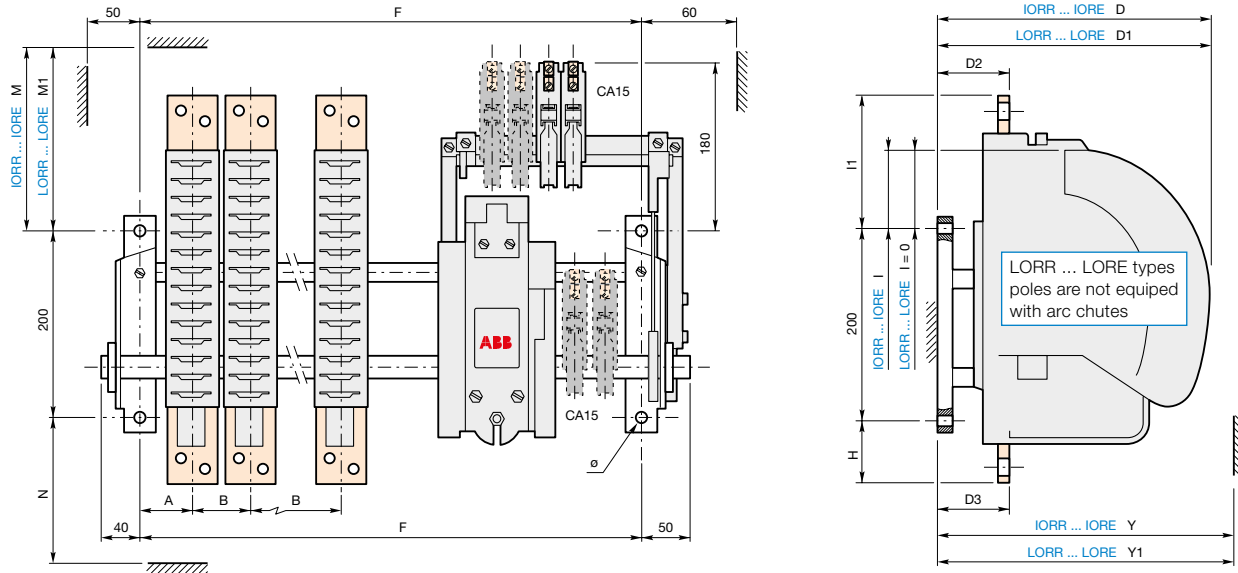

Terminal plate details

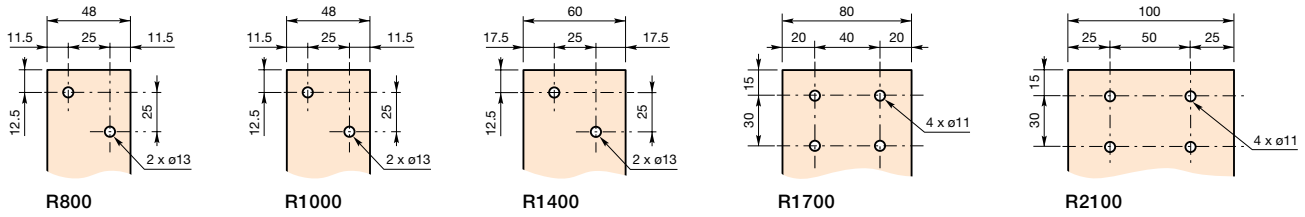

Terminal plate thickness: top terminal plates = 10 mm, bottom terminal plates = 12 mm

IORR ... IORE and LORR ... LORE types R800 ... R2100

Contactor types	Number of poles	Fixing dimension - F acc. to number of additional auxiliary contacts (refer to Auxiliary contact fitting details table, section 2):											Fixing holes ø
		0	1	2	3	4	5	6	7	8	9	10	
R800	1	245	245	245	285	285	285	285	345	345	345	345	4 x ø13
	2	345	345	345	385	385	385	385	445	445	445	445	
	3	385	385	385	445	445	445	445	540	540	540	540	
R1000	1	245	245	245	285	285	285	285	345	345	345	345	4 x ø13
	2	345	345	345	385	385	385	385	445	445	445	445	
	3	385	385	385	445	445	445	445	540	540	540	540	
R1400	1	285	285	285	345	345	345	345	385	385	385	385	4 x ø13
	2	385	385	385	445	445	445	445	540	540	540	540	
	3	540	540	540	635	635	635	635	635	635	635	635	
R1700	1	300	300	300	345	345	345	345	385	385	385	385	4 x ø13
	2	445	445	445	540	540	540	540	540	540	540	540	
	3	540	540	540	635	635	635	635	635	635	635	635	
R2100	1	300	300	300	345	345	345	345	385	385	385	385	4 x ø13
	2	445	445	445	540	540	540	540	540	540	540	540	
	3	540	540	540	635	635	635	635	635	635	635	635	

Contactor types	Number of poles	Dimensions													
		A	B	D	D1	D2	D3	H	I	I1	M	M1	N	Y	Y1
R800	1	60	-	325	260	75	77	70	108	98	158	115	85	345	280
	2	60	90	325	260	75	77	70	108	98	158	115	85	345	280
	3	60	70	325	260	75	77	70	108	98	158	115	85	345	280
R1000	1	60	-	325	260	75	77	70	108	98	158	115	85	345	280
	2	60	90	325	260	75	77	70	108	98	158	115	85	345	280
	3	60	70	325	260	75	77	70	108	98	158	115	85	345	280
R1400	1	85	-	325	260	75	77	70	108	98	228	165	100	400	280
	2	85	110	325	260	75	77	70	108	98	228	165	100	400	280
	3	85	120	325	260	75	77	70	108	98	228	165	100	400	280
R1700	1	85	-	325	260	75	77	84	108	112	258	165	125	425	280
	2	85	140	325	260	75	77	84	108	112	258	165	125	425	280
	3	85	120	325	260	75	77	84	108	112	258	165	125	425	280
R2100	1	85	-	325	260	75	77	84	108	112	258	165	125	425	280
	2	85	140	325	260	75	77	84	108	112	258	165	125	425	280
	3	85	120	325	260	75	77	84	108	112	258	165	125	425	280

Fixing -
 Dimensions -
 Clearing distances -
 Connecting



IORR ... IORE and LORR ... LORE types R2500 ... R5100

Main dimensions mm

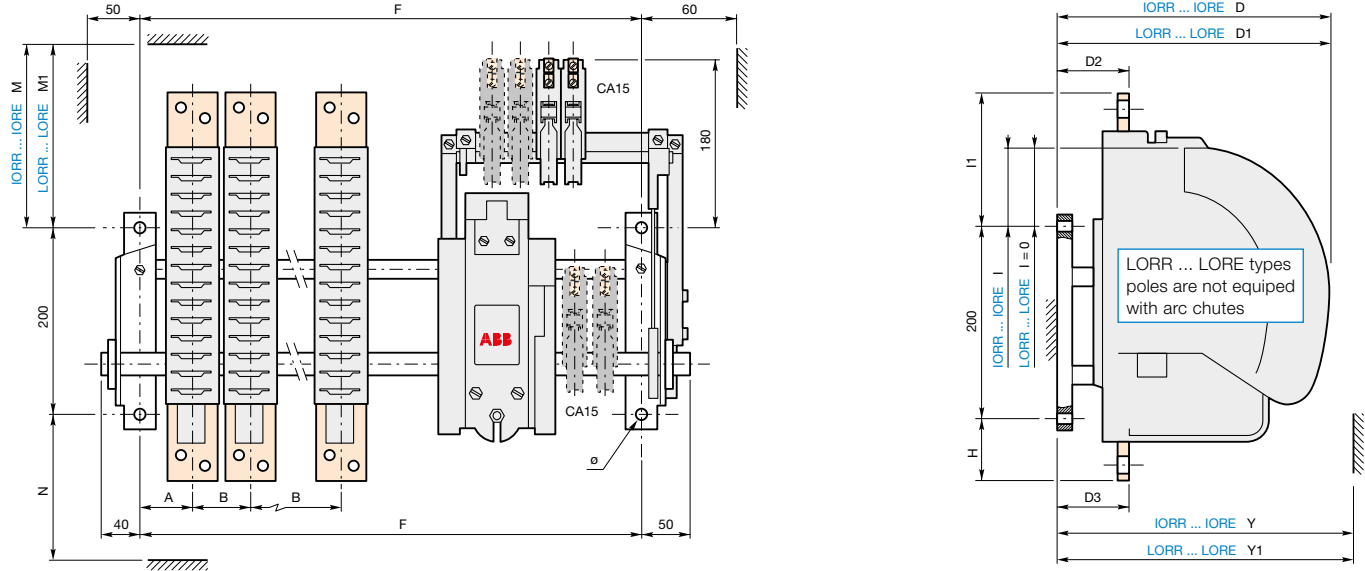

Fig 1 = right electro-magnet (see table in the following page)

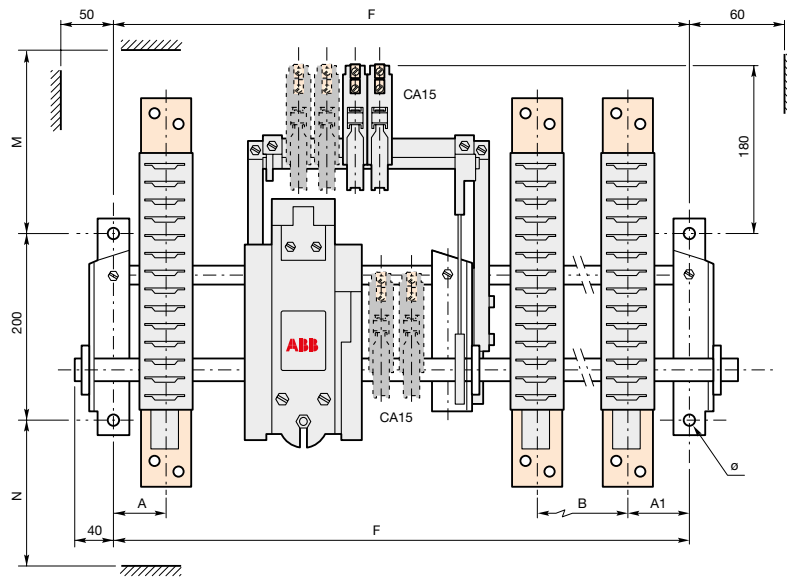
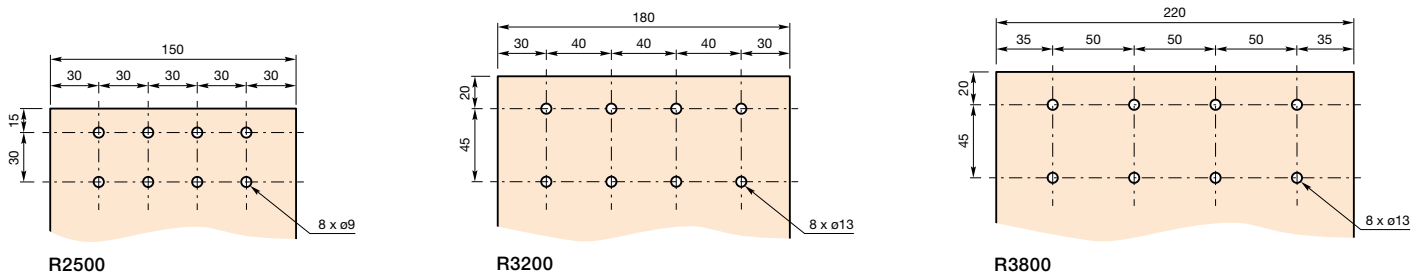

Fig 2 = central electro-magnet (see table in the following page)



Terminal plate thickness for R2500 ... R5100: top and bottom terminal plates = 10 mm

IORR ... IORE and LORR ... LORE types R2500 ... R5100

Contactor types	Number of poles	Fixing dimension - F acc. to number of additional auxiliary contacts (refer to Auxiliary contact fitting details table, section 2):											Fixing holes
		0	1	2	3	4	5	6	7	8	9	10	
R2500	1	385	385	385	445	445	445	445	540	540	540	540	4 x \varnothing 13
	2	635	635	635	635	635	635	635	-	-	-	-	
	3	950	950	950	1050	1050	1050	1050	1050	1050	1050	1050	
R3200	1	445	445	445	540	540	540	540	540	540	540	540	4 x \varnothing 13
	2	760	760	760	760	760	760	760	885	885	885	885	
	3	950	950	950	1050	1050	1050	1050	1050	1050	1050	1050	
R3800	1	445	445	445	540	540	540	540	540	540	540	540	4 x \varnothing 13
	2	760	760	760	885	885	885	885	885	885	885	885	
R4500	1	540	540	540	540	540	540	540	540	635	635	635	4 x \varnothing 13
	2	950	950	950	950	950	950	950	950	1050	1050	1050	
R5100	1	540	540	540	635	635	635	635	635	635	635	635	4 x \varnothing 13

Contactor types	Number of poles	Dimensions																Fig
		A	A1	B	D	D1	D2	D3	H	I	I1	M	M1	N	Y	Y1		
R2500	1	130	-	-	325	260	85	87	135	108	161	258	245	152	425	280	1	
	2	135	-	220	325	260	85	87	135	108	161	258	245	152	425	280	1	
	3	135	135	-	325	260	85	87	135	108	161	258	245	152	425	280	2	
R3200	1	150	-	-	325	260	99	87	174	108	202	300	245	215	450	280	1	
	2	135	135	-	325	260	99	87	174	108	202	300	245	215	450	280	2	
	3	135	135	-	325	260	99	87	174	108	202	300	245	215	450	280	2	
R3800	1	160	-	-	325	260	99	87	174	108	202	300	245	215	450	280	1	
	2	145	145	-	325	260	99	87	174	108	202	300	245	215	450	280	2	
R4500	1	185	-	-	325	260	99	87	174	108	202	300	245	215	450	280	1	
	2	185	180	-	325	260	99	87	174	108	202	300	245	215	450	280	2	
R5100	1	210	-	-	325	260	99	87	174	108	202	300	245	215	465	280	1	

Fixing -
 Dimensions -
 Clearing distances -
 Connecting

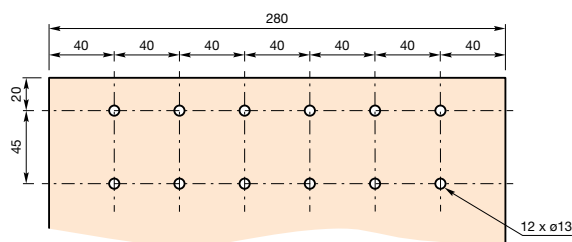

R4500

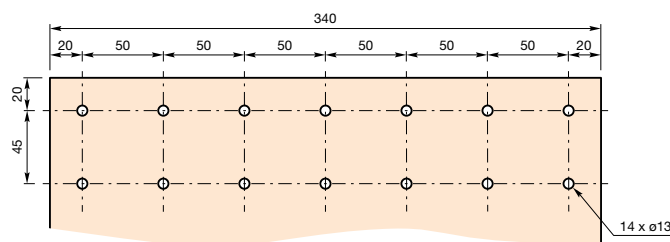

R5100

Terminal plate thickness for R2500 ... R5100: top and bottom terminal plates = 10 mm

IORR..MT ... IORE..MT and IORR..CC ... IORE..CC types R63 ... R500

Main dimensions mm

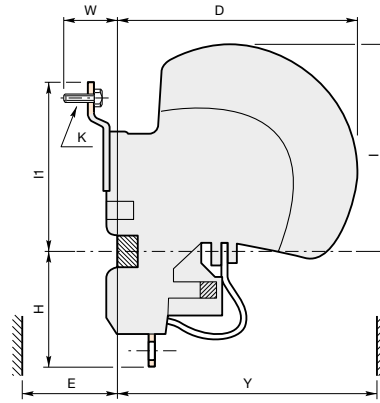
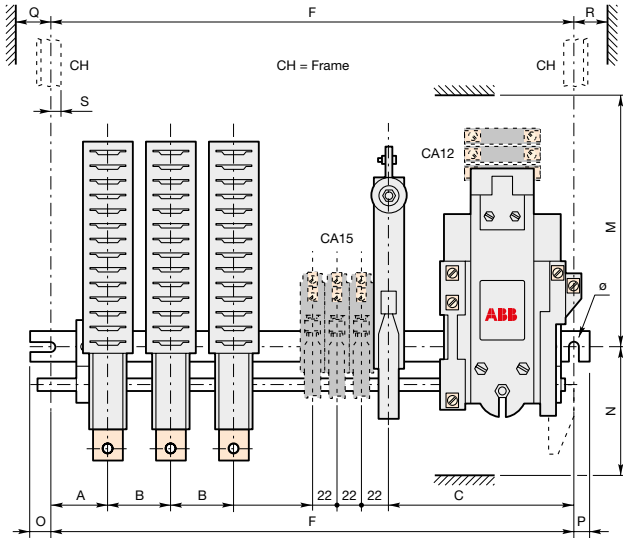

Terminal plate details



Lower terminal plate



Upper terminal plate



IORR..MT ... IORE..MT and IORR..CC ... IORE..CC types R63 ... R500

Contactor types	Number of poles	Fixing dimension - F acc. to number of additional auxiliary contacts (refer to Auxiliary contact fitting details table, section 2):										Fixing holes ø	
		0	1	2	3	4	5	6	7	8	9		10
R63	1	205	245	245	285	285	345	345	345	-	-	-	2 x ø7
	2	245	285	285	345	345	385	385	445	-	-	-	
	3	285	345	345	385	385	445	445	445	-	-	-	
	4	345	385	385	445	445	540	540	540	-	-	-	
R125	1	205	245	245	285	345	345	385	385	445	-	-	2 x ø7
	2	285	285	345	345	385	385	445	445	-	-	-	
	3	345	345	385	385	445	445	540	540	-	-	-	
	4	385	445	445	445	540	540	540	540	-	-	-	
R200	1	245	285	285	345	345	385	385	445	-	-	-	2 x ø9
	2	345	345	385	385	445	445	445	540	-	-	-	
	3	385	445	445	445	540	540	540	540	-	-	-	
	4	445	540	540	540	540	-	-	-	-	-	-	
R400	1	345	345	385	385	445	445	540	-	-	-	-	2 x ø13
	2	445	445	445	540	540	540	540	635	-	-	-	
	3	540	540	540	540	635	635	635	635	-	-	-	
	4	635	635	635	635	-	-	-	-	-	-	-	
R500	1	345	345	385	385	445	445	540	-	-	-	-	2 x ø13
	2	445	445	445	540	540	540	540	635	-	-	-	
	3	540	540	540	540	635	635	635	635	-	-	-	
	4	635	635	635	635	-	-	-	-	-	-	-	

Contactor types	Number of poles	Dimensions																				
		A	B	C	D	E	H	I	II	K	ℓ	M	N	O	P	Q	R	S	V	W	Y	Z
R63	1	45	-	93	148	36	63	114	101	M6 x 20	16	164	83	12.5	10.5	53	23	15	8	16	178	8
	2	45	50	93	148	36	63	114	101	M6 x 20	16	164	83	12.5	10.5	53	23	15	8	16	178	8
	3	45	50	93	148	36	63	114	101	M6 x 20	16	164	83	12.5	10.5	53	23	15	8	16	178	8
R125	1	57	-	93	153	40	76	138	130	M8 x 20	20	188	96	12.5	10.5	53	23	15	10	20	183	10
	2	57	61	93	153	40	76	138	130	M8 x 20	20	188	96	12.5	10.5	53	23	15	10	20	183	10
	3	57	61	93	153	40	76	138	130	M8 x 20	20	188	96	12.5	10.5	53	23	15	10	20	183	10
R200	1	69	-	116	190	40	93	140	123	M10 x 25	25	190	116	9	10	53	20	25	13	20	220	12
	2	69	68	116	190	40	93	140	123	M10 x 25	25	190	116	9	10	53	20	25	13	20	220	12
	3	69	68	116	190	40	93	140	123	M10 x 25	25	190	116	9	10	53	20	25	13	20	220	12
R400	1	79	-	160	260	100	118	230	195	ø13	30	253	150	15	14	53	20	20	20	46	290	20
	2	79	80	160	260	100	118	230	195	ø13	30	253	150	15	14	53	20	20	20	46	290	20
	3	79	80	160	260	100	118	230	195	ø13	30	253	150	15	14	53	20	20	20	46	290	20
R500	1	79	-	160	260	100	118	230	195	ø13	30	253	150	15	14	53	20	20	20	46	290	20
	2	79	80	160	260	100	118	230	195	ø13	30	253	150	15	14	53	20	20	20	46	290	20
	3	79	80	160	260	100	118	230	195	ø13	30	253	150	15	14	53	20	20	20	46	290	20

Fixing -
 Dimensions -
 Clearing distances -
 Connecting

IORR..MT ... IORE..MT and IORR..CC ... IORE..CC types R800 ... R2100

Main dimensions mm

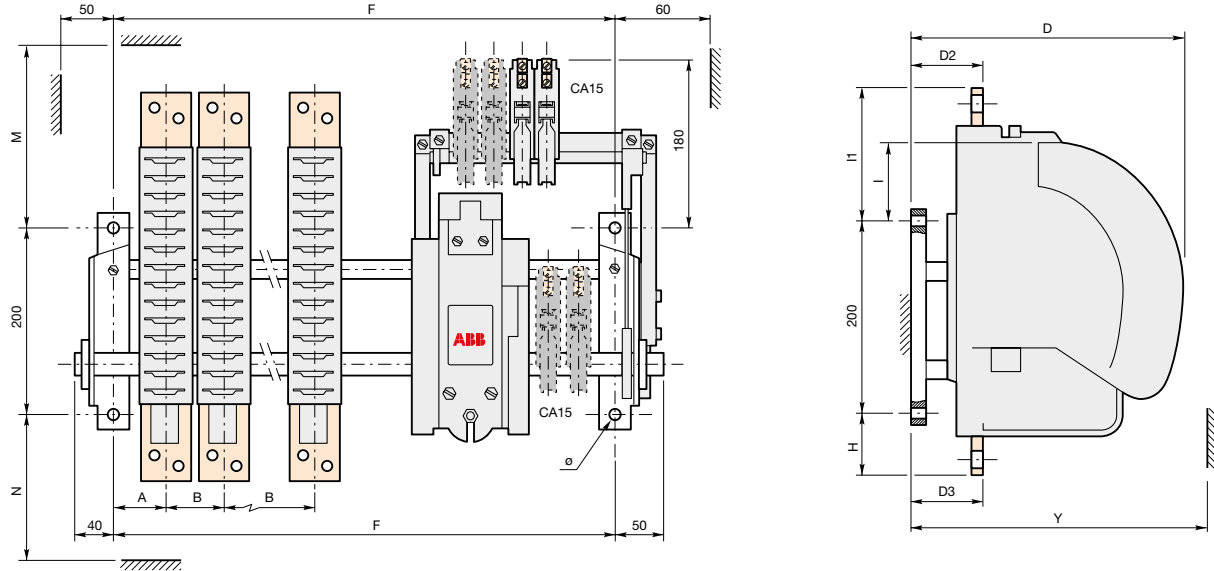

Terminal plate details

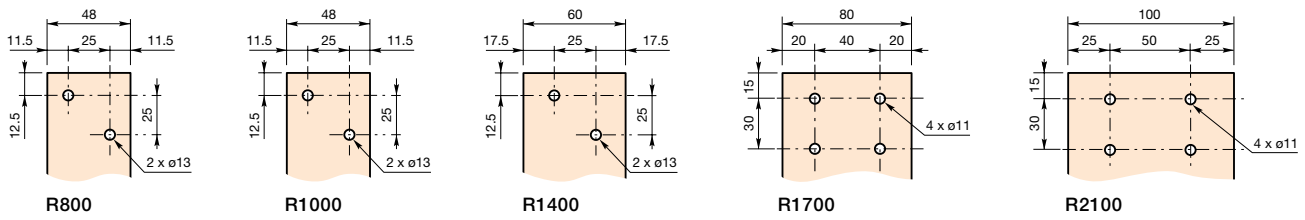

Terminal plate thickness: top terminal plates = 10 mm, bottom terminal plates = 12 mm

IORR..MT ... IORE..MT and IORR..CC ... IORE..CC types R800 ... R2100

Contactor types	Number of poles	Fixing dimension - F acc. to number of additional auxiliary contacts (refer to Auxiliary contact fitting details table, section 2):											Fixing holes
		0	1	2	3	4	5	6	7	8	9	10	
R800	1	245	245	245	285	285	285	285	345	345	345	345	4 x ø13
	2	345	345	345	385	385	385	385	445	445	445	445	
	3	385	385	385	445	445	445	445	540	540	540	540	
R1000 CC type only	1	285	285	285	345	345	345	345	345	345	345	345	4 x ø13
	2	345	345	345	385	385	385	385	445	445	445	445	
	3	445	445	445	540	540	540	540	540	540	540	540	
R1400	1	285	285	285	345	345	345	345	385	385	385	385	4 x ø13
	2	385	385	385	445	445	445	445	540	540	540	540	
	3	540	540	540	635	635	635	635	635	635	635	635	
R1700	1	300	300	300	345	345	345	345	385	385	385	385	4 x ø13
	2	445	445	445	540	540	540	540	540	540	540	540	
	3	540	540	540	635	635	635	635	635	635	635	635	
R2100	1	300	300	300	345	345	345	345	385	385	385	385	4 x ø13
	2	445	445	445	540	540	540	540	540	540	540	540	
	3	540	540	540	635	635	635	635	635	635	635	635	

Contactor types	Number of poles	Dimensions										
		A	B	D	D2	D3	H	I	I1	M	N	Y
R800	1	60	-	325	76	77	70	108	175	195	90	375
	2	60	90	325	76	77	70	108	175	195	90	375
	3	60	70	325	76	77	70	108	175	195	90	375
R1000	1	60	-	325	76	77	70	108	175	195	90	375
	2	60	90	325	76	77	70	108	175	195	90	375
	3	60	80	325	76	77	70	108	175	195	90	375
R1400	1	80	-	325	76	77	70	108	175	258	100	425
	2	80	110	325	76	77	70	108	175	258	100	425
	3	85	120	325	76	77	70	108	175	258	100	425
R1700	1	85	-	325	89	77	84	108	189	288	125	450
	2	85	140	325	89	77	84	108	189	288	125	450
	3	85	120	325	89	77	84	108	189	288	125	450
R2100	1	85	-	325	89	77	84	108	189	288	125	450
	2	85	140	325	89	77	84	108	189	288	125	450
	3	85	120	325	89	77	84	108	189	288	125	450

Fixing -
 Dimensions -
 Clearing distances -
 Connecting



IORR..MT ... IORE..MT and IORR..CC ... IORE..CC types R2500 ... R5100

Main dimensions mm

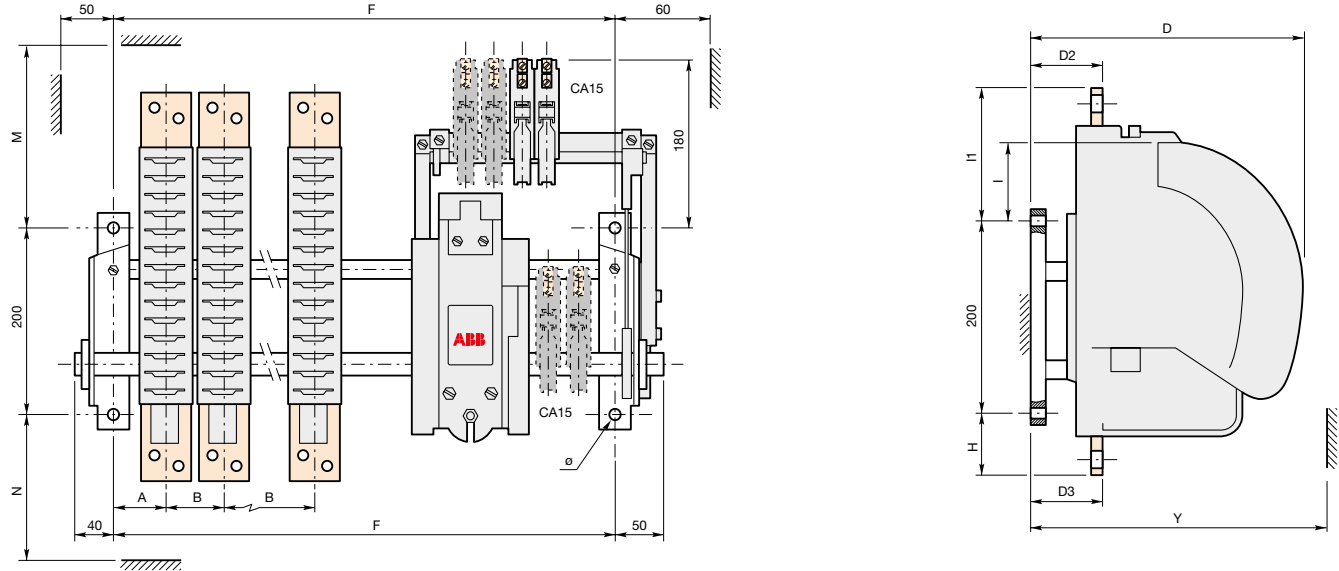

Fig 1 = right electro-magnet (see table in the following page)

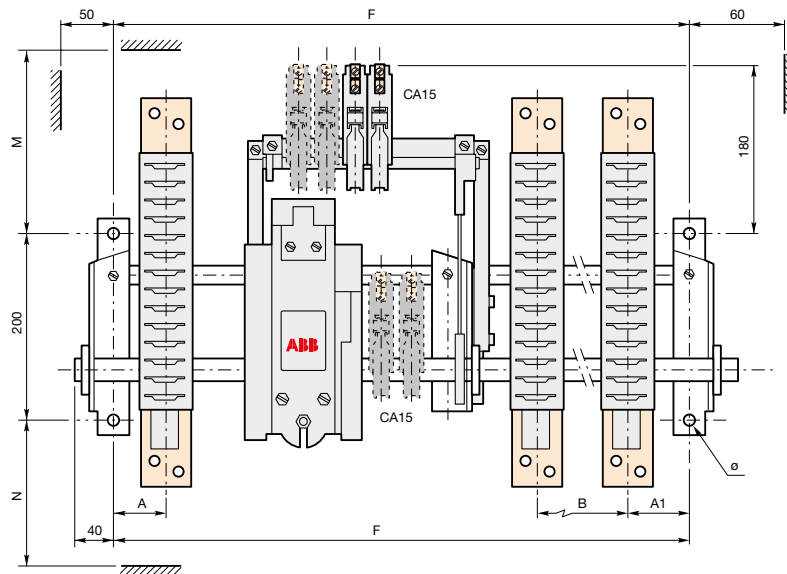
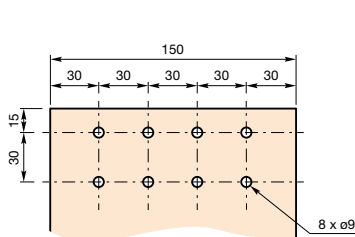
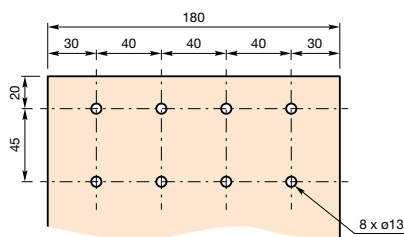

Fig 2 = central electro-magnet (see table in the following page)



R2500



R3200

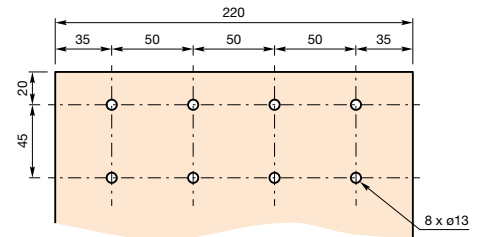

R3800

Terminal plate thickness for R2500 ... R5100: top and bottom terminal plates = 10 mm

IORR..MT ... IORE..MT and IORR..CC ... IORE..CC types R2500 ... R5100

Contactor types	Number of poles	Fixing dimension - F acc. to number of additional auxiliary contacts (refer to Auxiliary contact fitting details table, section 2):											Fixing holes ø
		0	1	2	3	4	5	6	7	8	9	10	
R2500	1	385	385	385	445	445	445	445	540	540	540	540	4 x ø13
	2	635	635	635	635	635	635	635	-	-	-	-	
	3	950	950	950	1050	1050	1050	1050	1050	1050	1050	1050	
R3200	1	445	445	445	540	540	540	540	540	540	540	540	4 x ø13
	2	760	760	760	760	760	760	760	885	885	885	885	
	3	950	950	950	1050	1050	1050	1050	1050	1050	1050	1050	
R3800	1	445	445	445	540	540	540	540	540	540	540	540	4 x ø13
	2	760	760	760	885	885	885	885	885	885	885	885	
R4500	1	540	540	540	540	540	540	540	635	635	635	635	4 x ø13
	2	950	950	950	950	950	950	950	1050	1050	1050	1050	
R5100	1	540	540	540	635	635	635	635	635	635	635	635	4 x ø13

Contactor types	Number of poles	Dimensions											Fig	
		A	A1	B	D	D2	D3	H	I	I1	M	N		Y
R2500	1	130	-	-	325	85	87	135	108	238	258	152	425	1
	2	135	-	220	325	85	87	135	108	238	258	152	425	1
	3	135	135	-	325	85	87	135	108	238	258	152	425	2
R3200	1	150	-	-	325	99	87	174	108	279	300	215	450	1
	2	135	135	-	325	99	87	174	108	279	300	215	450	2
	3	135	135	-	325	99	87	174	108	279	300	215	450	2
R3800	1	160	-	-	325	99	87	174	108	279	300	215	450	1
	2	145	145	-	325	99	87	174	108	279	300	215	450	2
R4500	1	185	-	-	325	99	87	174	108	279	300	215	450	1
	2	185	180	-	325	99	87	174	108	279	300	215	450	2
R5100	1	210	-	-	325	99	87	174	108	279	300	215	465	1

Fixing -
 Dimensions -
 Clearing distances -
 Connecting

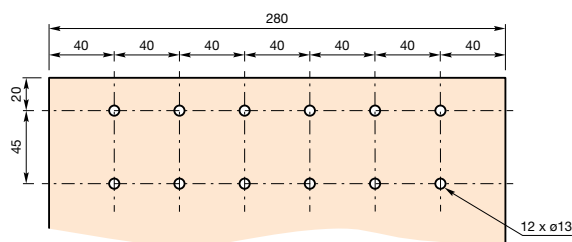

R4500

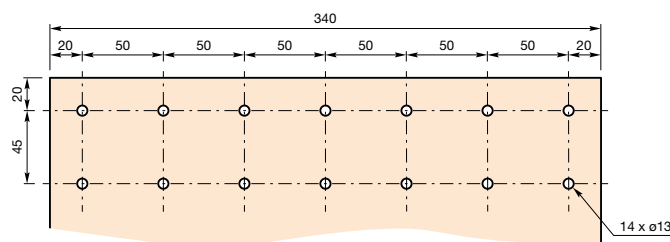

R5100

Terminal plate thickness for R2500 ... R5100: top and bottom terminal plates = 10 mm

IORR..AME ... IORE..AME and LORR..AME ... LORE..AME types R800 ... R2100

Main dimensions mm

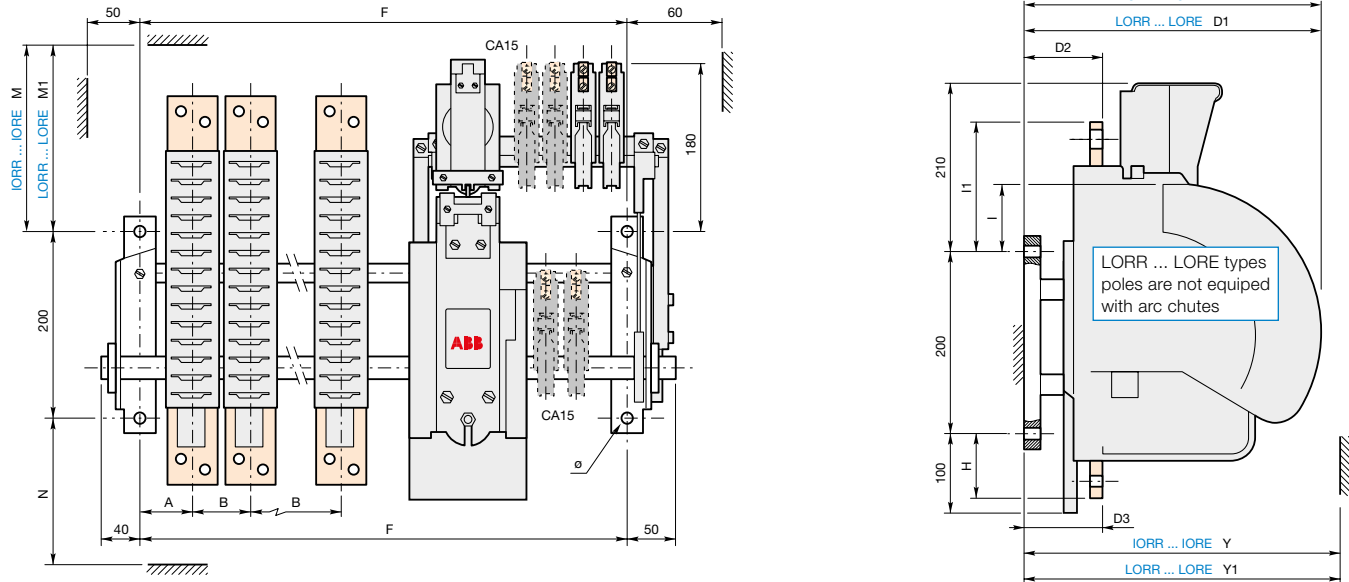

Terminal plate details

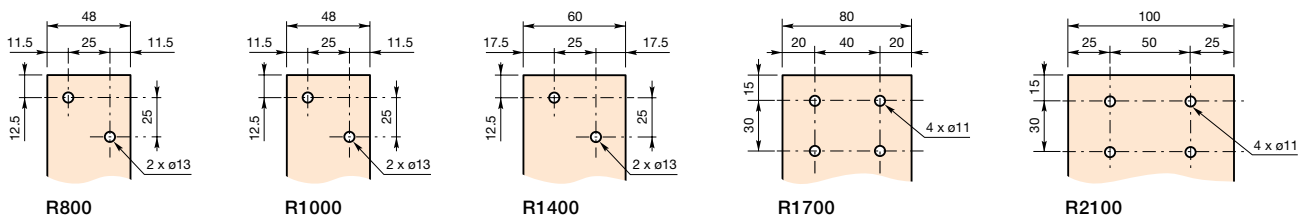

R800 **R1000** **R1400** **R1700** **R2100**
Terminal plate thickness: top terminal plates = 10 mm, bottom terminal plates = 12 mm



IORR..AME ... IORE..AME and LORR..AME ... LORE..AME types R800 ... R2100

Contactor types	Number of poles	Fixing dimension - F acc. to number of additional auxiliary contacts (refer to Auxiliary contact fitting details table, section 2):										Fixing holes ø		
		0	1	2	3	4	5	6	7	8	9		10	
R800	1	345	345	345	345	345	345	-	-	-	-	-	-	4 x ø13
	2	445	445	445	445	445	445	-	-	-	-	-	-	
	3	540	540	540	540	540	540	-	-	-	-	-	-	
R1000	1	345	345	345	345	345	345	-	-	-	-	-	-	4 x ø13
	2	445	445	445	445	445	445	-	-	-	-	-	-	
	3	540	540	540	540	540	540	-	-	-	-	-	-	
R1400	1	385	385	385	385	385	385	-	-	-	-	-	-	4 x ø13
	2	540	540	540	540	540	540	-	-	-	-	-	-	
	3	635	635	635	635	635	635	-	-	-	-	-	-	
R1700	1	385	385	385	385	385	385	-	-	-	-	-	-	4 x ø13
	2	540	540	540	540	540	540	-	-	-	-	-	-	
	3	635	635	635	635	635	635	-	-	-	-	-	-	
R2100	1	385	385	385	385	385	385	-	-	-	-	-	-	4 x ø13
	2	540	540	540	540	540	540	-	-	-	-	-	-	
	3	635	635	635	635	635	635	-	-	-	-	-	-	

Contactor types	Number of poles	Dimensions													
		A	B	D	D1	D2	D3	H	I	I1	M	M1	N	Y	Y1
R800	1	60	-	325	260	75	77	70	108	98	245	245	90	345	280
	2	60	90	325	260	75	77	70	108	98	245	245	90	345	280
	3	60	70	325	260	75	77	70	108	98	245	245	90	345	280
R1000	1	60	-	325	260	75	77	70	108	98	245	245	90	345	280
	2	60	90	325	260	75	77	70	108	98	245	245	90	345	280
	3	60	70	325	260	75	77	70	108	98	245	245	90	345	280
R1400	1	80	-	325	260	76	77	70	108	98	258	245	100	400	280
	2	80	110	325	260	76	77	70	108	98	258	245	100	400	280
	3	85	120	325	260	76	77	70	108	98	258	245	100	400	280
R1700	1	85	-	325	260	75	77	84	108	112	288	245	125	425	280
	2	85	140	325	260	75	77	84	108	112	288	245	125	425	280
	3	85	120	325	260	75	77	84	108	112	288	245	125	425	280
R2100	1	85	-	325	260	75	77	84	108	112	288	245	125	425	280
	2	85	140	325	260	75	77	84	108	112	288	245	125	425	280
	3	85	120	325	260	75	77	84	108	112	288	245	125	425	280

Fixing -
 Dimensions -
 Clearing distances -
 Connecting



IORR..AME ... IORE..AME and LORR..AME ... LORE..AME types R2500 ... R5100

Main dimensions mm

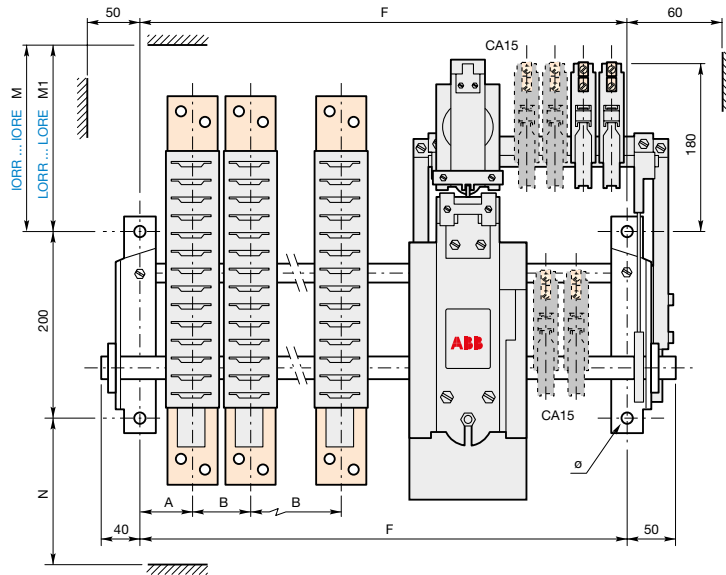

Fig 1 = right electro-magnet (see table in the following page)

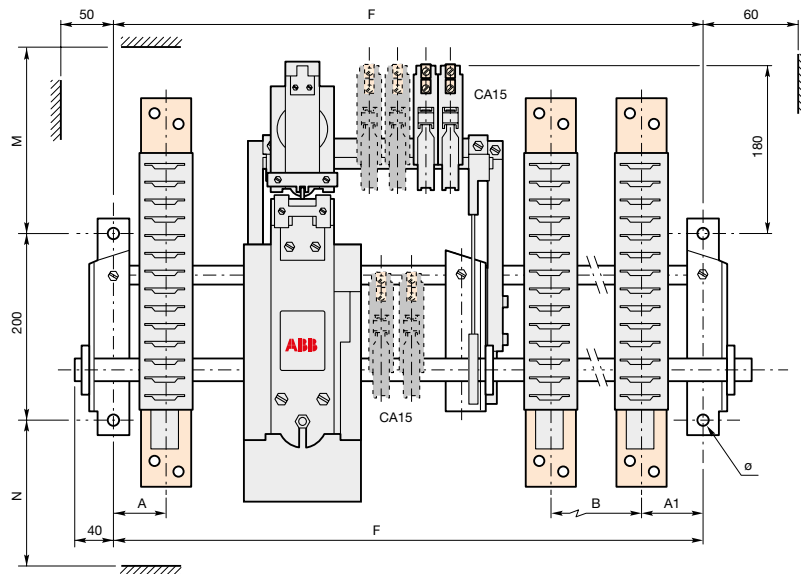
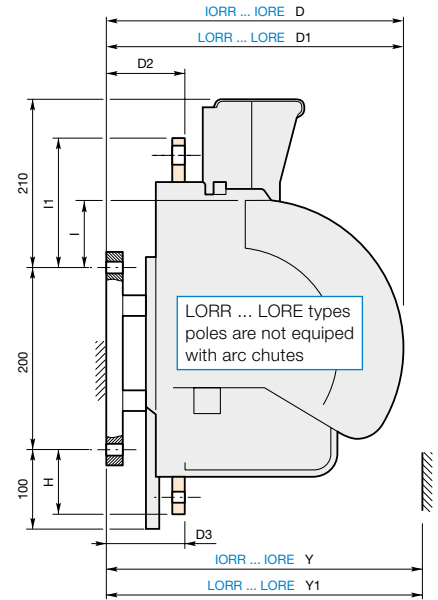
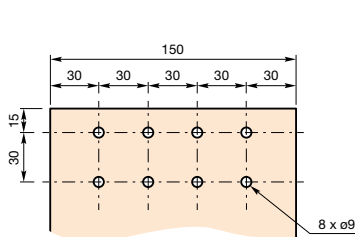
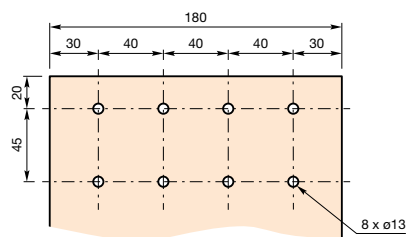

Fig 2 = central electro-magnet (see table in the following page)



R2500



R3200

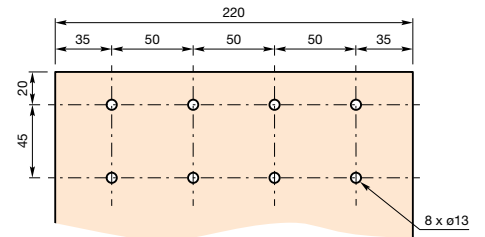

R3800

Terminal plate thickness for R2500 ... R5100: top and bottom terminal plates = 10 mm

IORR..AME ... IORE..AME and LORR..AME ... LORE..AME types R2500 ... R5100

Contactor types	Number of poles	Fixing dimension - F acc. to number of additional auxiliary contacts (refer to Auxiliary contact fitting details table, section 2):										Fixing holes		
		0	1	2	3	4	5	6	7	8	9		10	
R2500	1	540	540	540	540	540	540	-	-	-	-	-	-	4 x ϕ 13
	2	685	685	685	685	685	685	-	-	-	-	-	-	
	3	1050	1050	1050	1050	1050	1050	-	-	-	-	-	-	
R3200	1	540	540	540	540	540	540	-	-	-	-	-	-	4 x ϕ 13
	2	885	885	885	885	885	885	-	-	-	-	-	-	
	3	1050	1050	1050	1050	1050	1050	-	-	-	-	-	-	
R3800	1	540	540	540	540	540	540	-	-	-	-	-	-	4 x ϕ 13
	2	885	885	885	885	885	885	-	-	-	-	-	-	
R4500	1	635	635	635	635	635	635	-	-	-	-	-	-	4 x ϕ 13
	2	1050	1050	1050	1050	1050	1050	-	-	-	-	-	-	
R5100	1	635	635	635	635	635	635	-	-	-	-	-	-	4 x ϕ 13

Contactor types	Number of poles	Dimensions																Fig
		A	A1	B	D	D1	D2	D3	H	I	I1	M	M1	N	Y	Y1		
R2500	1	130	-	-	325	260	85	87	135	108	161	258	245	152	425	280	1	
	2	135	-	220	325	260	85	87	135	108	161	258	245	152	425	280	1	
	3	135	135	-	325	260	85	87	135	108	161	258	245	152	425	280	2	
R3200	1	150	-	-	325	260	99	87	174	108	202	300	245	215	450	280	1	
	2	135	135	-	325	260	99	87	174	108	202	300	245	215	450	280	2	
	3	135	135	-	325	260	99	87	174	108	202	300	245	215	450	280	2	
R3800	1	160	-	-	325	260	99	87	174	108	202	300	245	215	450	280	1	
	2	145	145	-	325	260	99	87	174	108	202	300	245	215	450	280	2	
R4500	1	185	-	-	325	260	99	87	174	108	202	300	245	215	450	280	1	
	2	185	180	-	325	260	99	87	174	108	202	300	245	215	450	280	2	
R5100	1	210	-	-	325	260	99	87	174	108	202	300	245	215	465	280	1	

Fixing -
 Dimensions -
 Clearing distances -
 Connecting

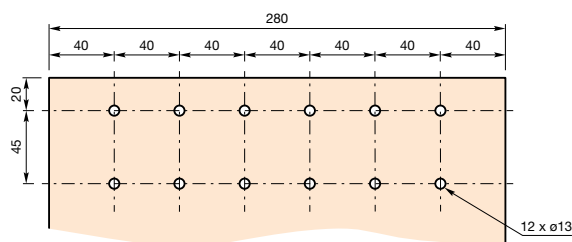

R4500

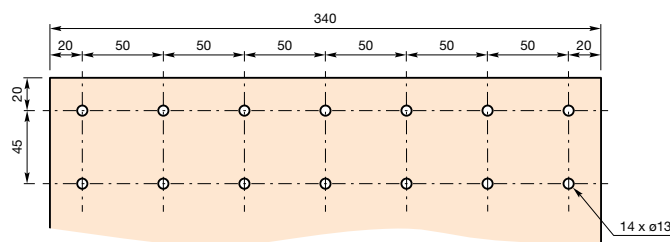

R5100

Terminal plate thickness for R2500 ... R5100: top and bottom terminal plates = 10 mm

IORR..MT-AMA ... IOR..MT-AMA and IORR..CC-AMA ... IOR..CC-AMA types R63 ... R200

Main dimensions mm

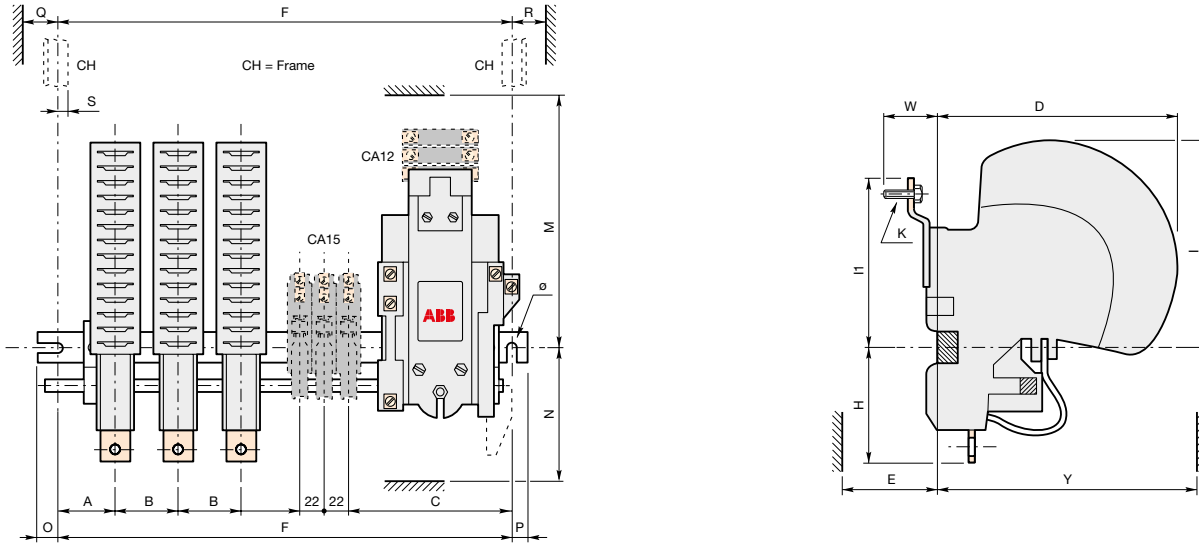

Terminal plate details



Lower terminal plate

Upper terminal plate



IORR..MT-AMA ... IOR..MT-AMA and IORR..CC-AMA ... IOR..CC-AMA types R63 ... R200

Contactor types	Number of poles	Fixing dimension - F acc. to number of additional auxiliary contacts (refer to Auxiliary contact fitting details table, section 2):										Fixing holes ø	
		0	1	2	3	4	5	6	7	8	9		10
R63	1	175	245	245	245	285	285	345	345	-	-	-	2 x ø7
	2	245	245	285	285	345	345	385	385	-	-	-	
	3	285	345	345	345	385	385	445	-	-	-	-	
	4	345	345	385	385	445	-	-	-	-	-	-	
R125	1	205	205	245	285	285	345	345	345	-	-	-	2 x ø7
	2	245	285	285	345	345	385	385	-	-	-	-	
	3	345	345	345	385	385	445	445	-	-	-	-	
	4	385	385	445	-	-	-	-	-	-	-	-	
R200	1	245	245	285	345	345	345	385	385	-	-	-	2 x ø9
	2	285	345	345	385	385	445	445	445	-	-	-	
	3	385	385	445	445	445	540	540	-	-	-	-	
	4	445	445	540	-	-	-	-	-	-	-	-	

Contactor types	Number of poles	Dimensions																				
		A	B	C	D	E	H	I	H	K	ℓ	M	N	O	P	Q	R	S	V	W	Y	Z
R63	1	45	-	93	148	36	63	114	101	M6 x 20	16	164	83	12.5	10.5	53	23	15	8	16	178	8
	2	45	50	93	148	36	63	114	101	M6 x 20	16	164	83	12.5	10.5	53	23	15	8	16	178	8
	3	45	50	93	148	36	63	114	101	M6 x 20	16	164	83	12.5	10.5	53	23	15	8	16	178	8
R125	1	57	-	93	153	40	76	138	130	M8 x 20	20	188	96	12.5	10.5	53	23	15	10	20	183	10
	2	57	61	93	153	40	76	138	130	M8 x 20	20	188	96	12.5	10.5	53	23	15	10	20	183	10
	3	57	61	93	153	40	76	138	130	M8 x 20	20	188	96	12.5	10.5	53	23	15	10	20	183	10
R200	1	69	-	116	190	40	93	140	123	M10 x 25	25	190	116	9	10	53	20	25	13	20	220	12
	2	69	68	116	190	40	93	140	123	M10 x 25	25	190	116	9	10	53	20	25	13	20	220	12
	3	69	68	116	190	40	93	140	123	M10 x 25	25	190	116	9	10	53	20	25	13	20	220	12

Fixing -
 Dimensions -
 Clearing distances -
 Connecting



IORR..MT-AME ... IORE..MT-AME and IORR..CC-AME ... IORE..CC-AME types R400 ... R500

Main dimensions mm

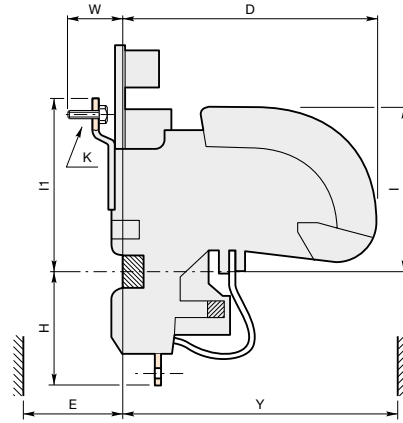
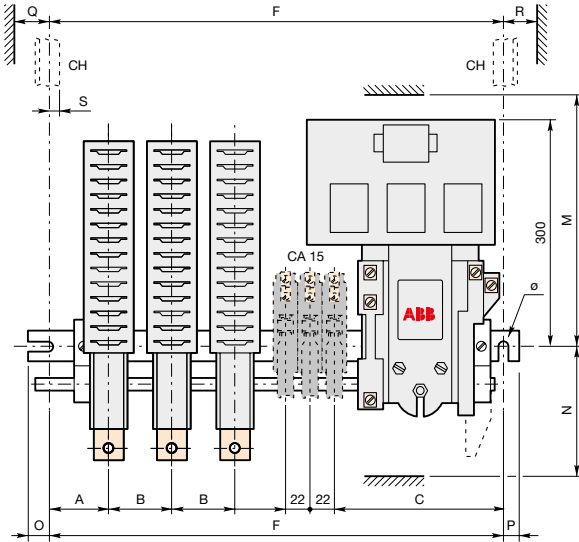

Terminal plate details



Lower terminal plate



Upper terminal plate



IORR..MT-AME ... IORE..MT-AME and IORR..CC-AME ... IORE..CC-AME types R400 ... R500

Contactor types	Number of poles	Fixing dimension - F acc. to number of additional auxiliary contacts (refer to Auxiliary contact fitting details table, section 2):											Fixing holes
		0	1	2	3	4	5	6	7	8	9	10	
R400	1	345	345	385	385	445	445	445	540	540	-	-	2 x \varnothing 13
	2	445	445	445	540	540	540	540	635	635	-	-	
	3	540	540	540	540	635	635	635	635	760	-	-	
	4	635	635	635	635	-	-	-	-	-	-	-	
R500	1	345	345	385	385	445	445	445	540	540	-	-	2 x \varnothing 13
	2	445	445	445	540	540	540	540	635	635	-	-	
	3	540	540	540	540	635	635	635	635	760	-	-	
	4	635	635	635	635	-	-	-	-	-	-	-	

Contactor types	Number of poles	Dimensions																				
		A	B	C	D	E	H	I	II	K	ℓ	M	N	O	P	Q	R	S	V	W	Y	Z
R400	1	79	-	160	260	100	118	230	195	\varnothing 13	30	313	150	15	14	53	20	20	20	46	335	20
	2	79	80	160	260	100	118	230	195	\varnothing 13	30	313	150	15	14	53	20	20	20	46	335	20
	3	79	80	160	260	100	118	230	195	\varnothing 13	30	313	150	15	14	53	20	20	20	46	335	20
R500	1	79	-	160	260	100	118	230	195	\varnothing 13	30	313	150	15	14	53	20	20	20	46	335	20
	2	79	80	160	260	100	118	230	195	\varnothing 13	30	313	150	15	14	53	20	20	20	46	335	20
	3	79	80	160	260	100	118	230	195	\varnothing 13	30	313	150	15	14	53	20	20	20	46	335	20

Fixing -
 Dimensions -
 Clearing distances -
 Connecting



IORR..MT-AME ... IORE..MT-AME and IORR..CC-AME ... IORE..CC-AME types R800 ... R2100

Main dimensions mm

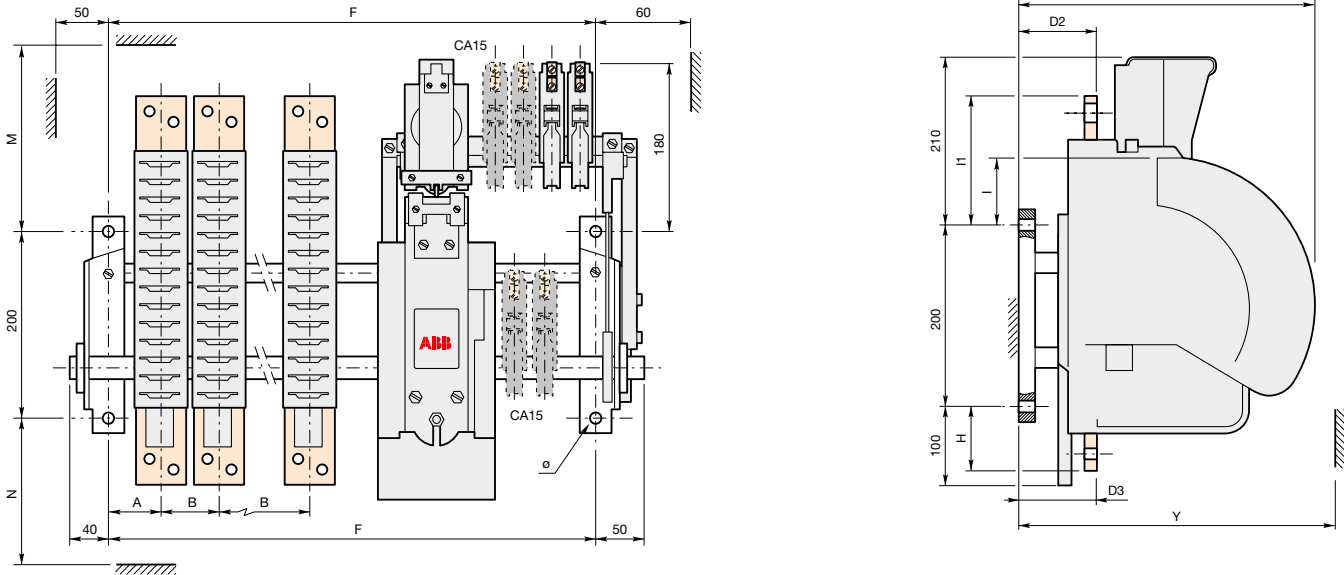

Terminal plate details

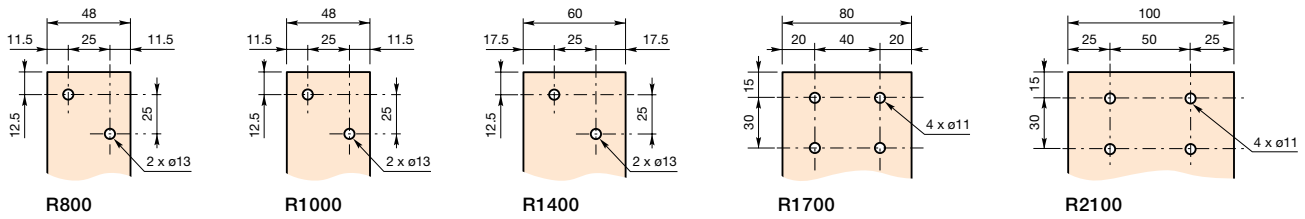

Terminal plate thickness: top terminal plates = 10 mm, bottom terminal plates = 12 mm



IORR..MT-AME ... IORE..MT-AME and IORR..CC-AME ... IORE..CC-AME types R800 ... R2100

Contactor types	Number of poles	Fixing dimension - F acc. to number of additional auxiliary contacts (refer to Auxiliary contact fitting details table, section 2):										Fixing holes ø		
		0	1	2	3	4	5	6	7	8	9		10	
R800	1	345	345	345	345	345	345	-	-	-	-	-	-	4 x ø13
	2	445	445	445	445	445	445	-	-	-	-	-	4 x ø13	
	3	540	540	540	540	540	540	-	-	-	-	-		
R1000 CC type only	1	345	345	345	345	345	345	-	-	-	-	-	-	4 x ø13
	2	445	445	445	445	445	445	-	-	-	-	-	4 x ø13	
	3	540	540	540	540	540	540	-	-	-	-	-		
R1400	1	385	385	385	385	385	385	-	-	-	-	-	-	4 x ø13
	2	540	540	540	540	540	540	-	-	-	-	-	4 x ø13	
	3	635	635	635	635	635	635	-	-	-	-	-		
R1700	1	385	385	385	385	385	385	-	-	-	-	-	-	4 x ø13
	2	540	540	540	540	540	540	-	-	-	-	-	4 x ø13	
	3	635	635	635	635	635	635	-	-	-	-	-		
R2100	1	385	385	385	385	385	385	-	-	-	-	-	-	4 x ø13
	2	540	540	540	540	540	540	-	-	-	-	-	4 x ø13	
	3	635	635	635	635	635	635	-	-	-	-	-		

Contactor types	Number of poles	Dimensions										
		A	B	D	D2	D3	H	I	I1	M	N	Y
R800	1	60	-	325	76	77	70	108	175	245	90	375
	2	60	90	325	76	77	70	108	175	245	90	375
	3	60	70	325	76	77	70	108	175	245	90	375
R1000	1	60	-	325	76	77	70	108	175	245	90	375
	2	60	90	325	76	77	70	108	175	245	90	375
	3	60	80	325	76	77	70	108	175	245	90	375
R1400	1	80	-	325	76	77	70	108	175	258	100	425
	2	80	100	325	76	77	70	108	175	258	100	425
	3	85	120	325	76	77	70	108	175	258	100	425
R1700	1	85	-	325	89	77	84	108	189	288	125	450
	2	85	140	325	89	77	84	108	189	288	125	450
	3	85	120	325	89	77	84	108	189	288	125	450
R2100	1	85	-	325	89	77	84	108	189	288	125	450
	2	85	140	325	89	77	84	108	189	288	125	450
	3	85	120	325	89	77	84	108	189	288	125	450

Fixing -
 Dimensions -
 Clearing distances -
 Connecting



IORR..MT-AME ... IORE..MT-AME and IORR..CC-AME ... IORE..CC-AME types R2500 ... R5100

Main dimensions mm

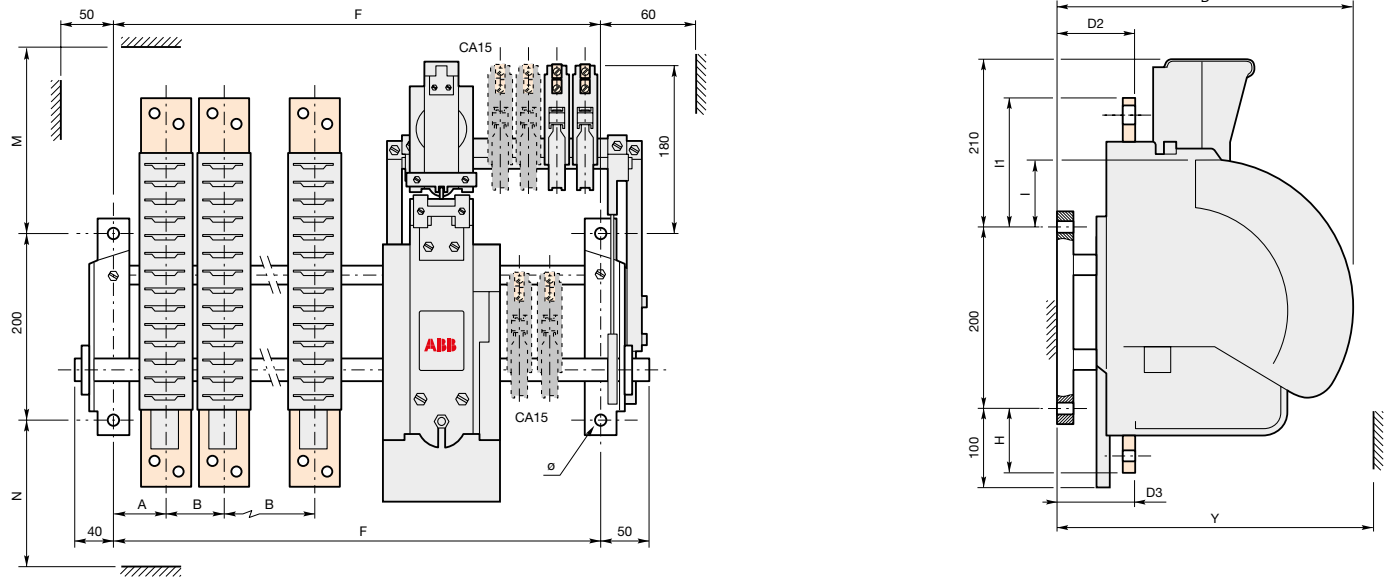

Fig 1 = right electro-magnet (see table in the following page)

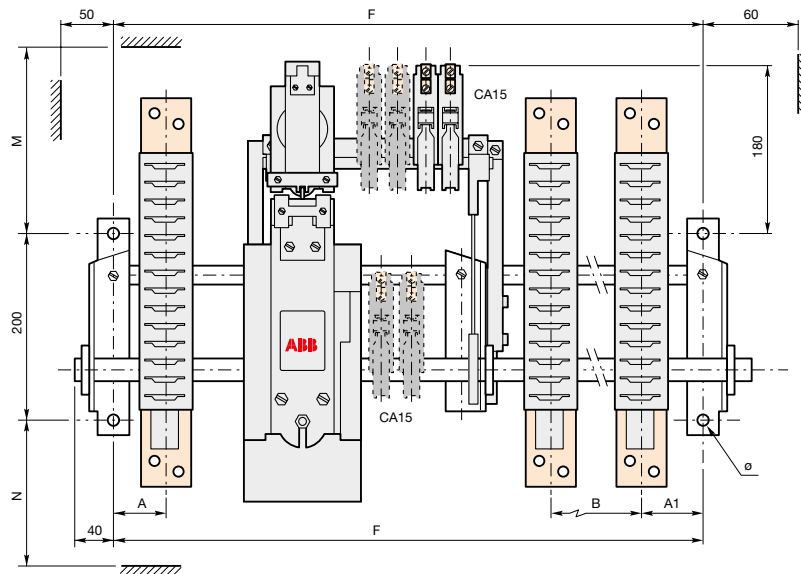
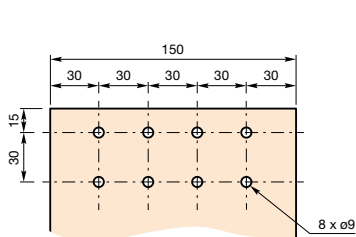
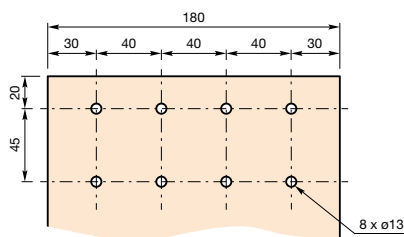

Fig 2 = central electro-magnet (see table in the following page)



R2500



R3200

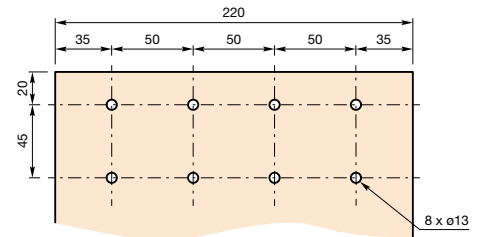

R3800

Terminal plate thickness for R2500 ... R5100: top and bottom terminal plates = 10 mm

IORR..MT-AME ... IORE..MT-AME and IORR..CC-AME ... IORE..CC-AME types R2500 ... R5100

Contactor types	Number of poles	Fixing dimension - F acc. to number of additional auxiliary contacts (refer to Auxiliary contact fitting details table, section 2):											Fixing holes ø	
		0	1	2	3	4	5	6	7	8	9	10		
R2500	1	540	540	540	540	540	540	-	-	-	-	-	-	4 x ø13
	2	685	685	685	685	685	685	-	-	-	-	-	-	
	3	1050	1050	1050	1050	1050	1050	-	-	-	-	-	-	
R3200	1	540	540	540	540	540	540	-	-	-	-	-	-	4 x ø13
	2	885	885	885	885	885	885	-	-	-	-	-	-	
	3	1050	1050	1050	1050	1050	1050	-	-	-	-	-	-	
R3800	1	540	540	540	540	540	540	-	-	-	-	-	-	4 x ø13
	2	885	885	885	885	885	885	-	-	-	-	-	-	
R4500	1	635	635	635	635	635	635	-	-	-	-	-	-	4 x ø13
	2	1050	1050	1050	1050	1050	1050	-	-	-	-	-	-	
R5100	1	635	635	635	635	635	635	-	-	-	-	-	-	4 x ø13

Contactor types	Number of poles	Dimensions													
		A	A1	B	D	B1	D2	D3	H	I	I1	M	N	Y	Fig
R2500	1	130	-	-	325	-	85	87	135	108	238	258	152	425	1
	2	135	-	220	325	-	85	87	135	108	238	258	152	425	1
	3	135	135	220	325	-	85	87	135	108	238	258	152	425	2
R3200	1	150	-	-	325	-	99	87	174	108	279	300	215	450	1
	2	135	135	-	325	-	99	87	174	108	279	300	215	450	2
	3	135	-	-	325	-	99	87	174	108	279	300	215	450	2
R3800	1	160	-	-	325	-	99	87	174	108	279	300	215	450	1
	2	145	145	-	325	-	99	87	174	108	279	300	215	450	2
R4500	1	185	-	-	325	-	99	87	174	108	279	300	215	450	1
	2	185	180	-	325	-	99	87	174	108	279	300	215	450	2
R5100	1	210	-	-	325	-	99	87	174	108	279	300	215	465	1

Fixing -
 Dimensions -
 Clearing distances -
 Connecting

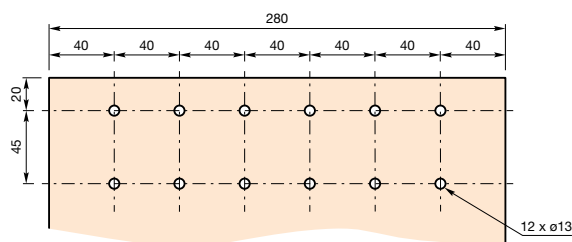

R4500

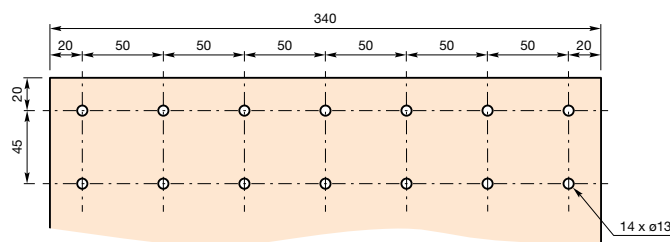

R5100

Terminal plate thickness for R2500 ... R5100: top and bottom terminal plates = 10 mm

NORR..MT ... NORE..MT and NORR..CC ... NORE..CC types R63 ... R200

Main dimensions mm

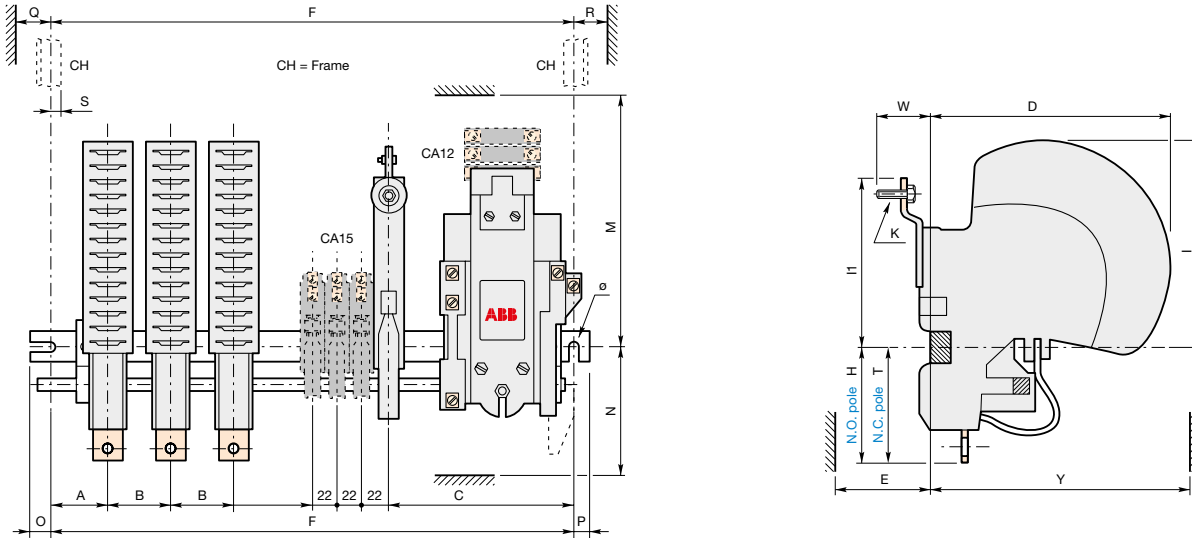

Terminal plate details



Lower terminal plate



Upper terminal plate



NORR..MT ... NORE..MT and NORR..CC ... NORE..CC types R63 ... R200

Contactor types	Number of poles	Fixing dimension - F acc. to number of additional auxiliary contacts (refer to Auxiliary contact fitting details table, section 2):											Fixing holes
		0	1	2	3	4	5	6	7	8	9	10	
R63	1	205	245	245	285	285	345	345	345	-	-	-	2 x ø7
	2	245	285	285	345	345	385	385	445	-	-	-	
	3	285	345	345	385	385	445	445	445	-	-	-	
	4	345	385	385	445	445	540	540	540	-	-	-	
R125	1	205	245	245	285	345	345	385	385	445	-	-	2 x ø7
	2	285	285	345	345	385	385	445	445	-	-	-	
	3	345	345	385	385	445	445	540	540	-	-	-	
	4	385	445	445	445	540	540	540	540	-	-	-	
R200	1	245	285	285	345	345	385	385	445	-	-	-	2 x ø9
	2	345	345	385	385	445	445	445	540	-	-	-	
	3	385	445	445	445	540	540	540	540	-	-	-	
	4	445	540	540	540	540	-	-	-	-	-	-	

Contactor types	Number of poles	Dimensions																					
		A	B	C	D	E	H	I	I1	K	ℓ	M	N	O	P	Q	R	S	T	V	W	Y	Z
R63	1	45	-	93	148	36	63	114	101	M6 x 20	16	164	111	12.5	10.5	53	23	15	96	8	16	178	8
	2	45	50	93	148	36	63	114	101	M6 x 20	16	164	111	12.5	10.5	53	23	15	96	8	16	178	8
	3	45	50	93	148	36	63	114	101	M6 x 20	16	164	111	12.5	10.5	53	23	15	96	8	16	178	8
	4	45	50	93	148	36	63	114	101	M6 x 20	16	164	111	12.5	10.5	53	23	15	96	8	16	178	8
R125	1	57	-	93	153	40	76	138	130	M8 x 20	20	188	126	12.5	10.5	53	23	15	111	10	20	183	10
	2	57	61	93	153	40	76	138	130	M8 x 20	20	188	126	12.5	10.5	53	23	15	111	10	20	183	10
	3	57	61	93	153	40	76	138	130	M8 x 20	20	188	126	12.5	10.5	53	23	15	111	10	20	183	10
	4	57	61	93	153	40	76	138	130	M8 x 20	20	188	126	12.5	10.5	53	23	15	111	10	20	183	10
R200	1	69	-	116	190	40	93	140	123	M10 x 25	25	190	143	9	10	53	20	25	125	13	20	220	12
	2	69	68	116	190	40	93	140	123	M10 x 25	25	190	143	9	10	53	20	25	125	13	20	220	12
	3	69	68	116	190	40	93	140	123	M10 x 25	25	190	143	9	10	53	20	25	125	13	20	220	12
	4	69	68	116	190	40	93	140	123	M10 x 25	25	190	143	9	10	53	20	25	125	13	20	220	12

Fixing -
 Dimensions -
 Clearing distances -
 Connecting



LORR and LORE types R85 ... R550

Main dimensions mm

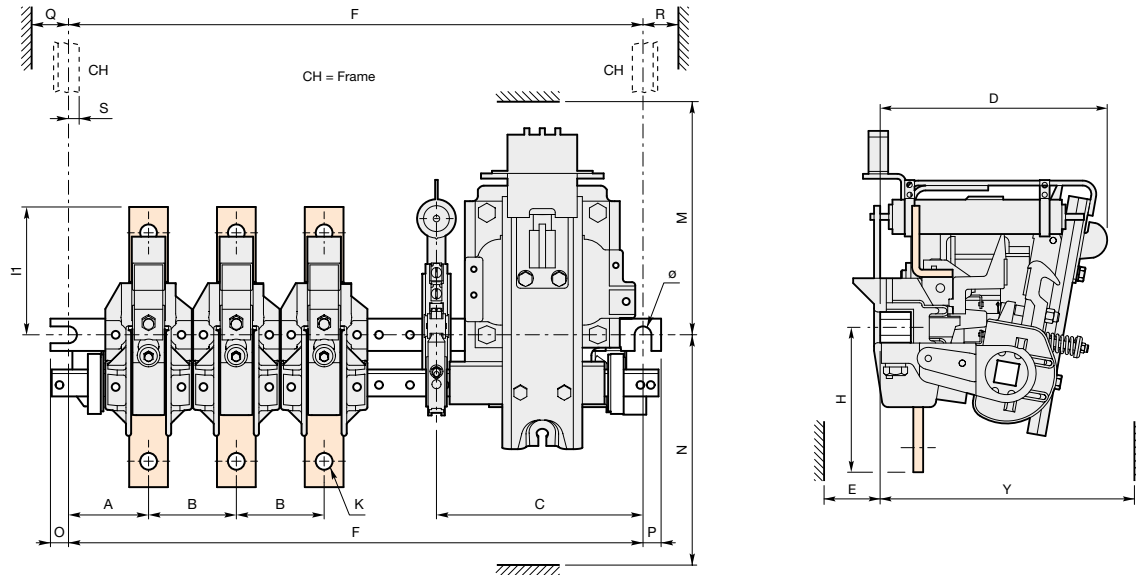

Terminal plate details

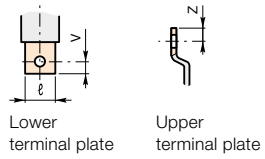

9

Lower terminal plate

Upper terminal plate

LORR and LORE types

R85 ... R550

Contactor types	Number of poles	Fixing dimension - F acc. to number of additional auxiliary contacts (refer to Auxiliary contact fitting details table, section 2):										Fixing holes		
		0	1	2	3	4	5	6	7	8	9		10	
R85	1	175	205	245	245	285	285	345	345	345	-	-	-	2 x ø7
	2	205	245	245	285	285	345	345	345	-	-	-		
	3	245	285	285	345	345	345	385	445	-	-	-		
	4	345	385	385	345	445	540	540	540	-	-	-		
R170	1	175	205	245	245	285	285	345	345	345	-	-	-	2 x ø7
	2	245	245	285	345	345	345	385	385	-	-	-		
	3	285	345	345	345	385	385	445	445	-	-	-		
	4	345	345	385	385	445	445	445	540	-	-	-		
R260	1	205	245	285	285	345	345	345	385	-	-	-	2 x ø9	
	2	285	285	345	345	385	385	445	445	-	-	-		
	3	345	345	385	385	445	445	540	540	-	-	-		
	4	385	445	445	445	540	540	540	540	-	-	-		
R400	1	345	345	345	345	385	445	445	445	-	-	-	2 x ø13	
	2	385	385	445	445	445	540	540	540	-	-	-		
	3	445	445	540	540	540	540	635	635	-	-	-		
	4	540	540	540	635	635	635	635	-	-	-	-		
R550	1	345	345	345	345	385	445	445	445	-	-	-	2 x ø13	
	2	385	385	445	445	445	540	540	540	-	-	-		
	3	445	445	540	540	540	540	635	635	-	-	-		
	4	540	540	540	635	635	635	635	-	-	-	-		

Contactor types	Number of poles	Dimensions																		
		A	B	C	D	E	H	H	K	ℓ	M	N	O	P	Q	R	S	V	Y	Z
R85	1	35	-	93	110	36	63	101	M6 x 20	16	150	83	12.5	10.5	53	23	15	8	125	8
	2	35	37	93	110	36	63	101	M6 x 20	16	150	83	12.5	10.5	53	23	15	8	125	8
	3	35	37	93	110	36	63	101	M6 x 20	16	150	83	12.5	10.5	53	23	15	8	125	8
	4	35	37	93	110	36	63	101	M6 x 20	16	150	83	12.5	10.5	53	23	15	8	125	8
R170	1	41	-	93	110	40	76	130	M8 x 20	20	150	96	12.5	10.5	53	23	15	10	125	10
	2	41	46	93	110	40	76	130	M8 x 20	20	150	96	12.5	10.5	53	23	15	10	125	10
	3	41	46	93	110	40	76	130	M8 x 20	20	150	96	12.5	10.5	53	23	15	10	125	10
	4	41	46	93	110	40	76	130	M8 x 20	20	150	96	12.5	10.5	53	23	15	10	125	10
R260	1	48	-	116	130	40	93	123	M10 x 25	25	167	116	9	10	53	20	25	13	145	12
	2	45	54.5	116	130	40	93	123	M10 x 25	25	167	116	9	10	53	20	25	13	145	12
	3	48	54.5	116	130	40	93	123	M10 x 25	25	167	116	9	10	53	20	25	13	145	12
	4	48	54.5	116	130	40	93	123	M10 x 25	25	167	116	9	10	53	20	25	13	145	12
R400	1	62	-	160	178	100	118	195	ø13	30	142	150	15	14	53	20	20	20	193	20
	2	62	68	160	178	100	118	195	ø13	30	142	150	15	14	53	20	20	20	193	20
	3	62	68	160	178	100	118	195	ø13	30	142	150	15	14	53	20	20	20	193	20
	4	62	68	160	178	100	118	195	ø13	30	142	150	15	14	53	20	20	20	193	20
R550	1	62	-	160	178	100	118	195	ø13	30	142	150	15	14	53	20	20	20	193	20
	2	62	68	160	178	100	118	195	ø13	30	142	150	15	14	53	20	20	20	193	20
	3	62	68	160	178	100	118	195	ø13	30	142	150	15	14	53	20	20	20	193	20
	4	62	68	160	178	100	118	195	ø13	30	142	150	15	14	53	20	20	20	193	20

Fixing -
 Dimensions -
 Clearing distances -
 Connecting

AM-CC-NOR..21 and AM-CC-NOR..31 types R63 ... R200

Main dimensions mm

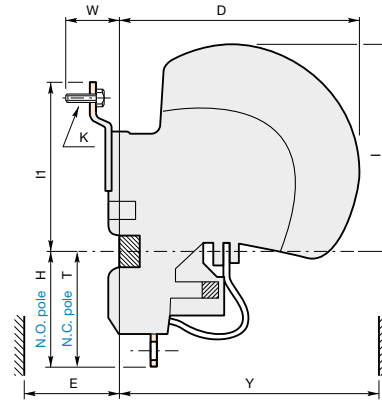
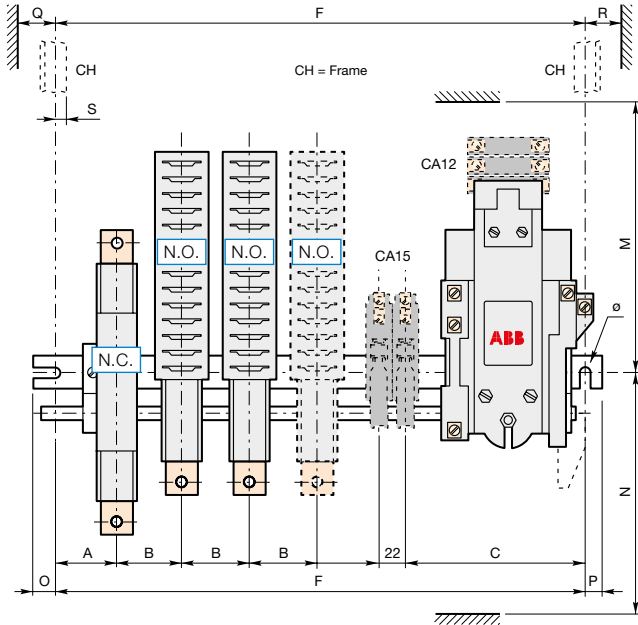

Terminal plate details



Lower terminal plate



Upper terminal plate



AM-CC-NOR..21 and AM-CC-NOR..31 types R63 ... R200

Contactor types	Number of poles	Fixing dimension - F acc. to number of CA15 auxiliary contacts:				Fixing holes
		5	6	8	10	
R63	21	345	445	445	540	2 x ø7
	31	445	-	-	-	
R125	21	385	-	-	-	2 x ø7
	31	445	-	-	-	
R200	21	445	540	540	540	2 x ø9
	31	540	-	-	-	

Contactor types	Number of poles	Dimensions																					
		A	B	C	D	E	H	I	I1	K	ℓ	M	N	O	P	Q	R	S	T	V	W	Y	Z
R63	21	45	50	93	148	36	63	114	101	M6 x 20	16	164	130	12.5	10.5	25	23	15	96	8	16	178	8
	31	45	50	93	148	36	63	114	101	M6 x 20	16	164	130	12.5	10.5	25	23	15	96	8	16	178	8
R125	21	57	61	93	153	40	76	138	130	M8 x 20	20	188	145	12.5	10.5	25	23	15	111	10	20	183	10
	31	57	61	93	153	40	76	138	130	M8 x 20	20	188	145	12.5	10.5	25	23	15	111	10	20	183	10
R200	21	69	68	116	190	40	93	140	123	M10 x 25	25	190	145	9	10	20	20	25	125	13	20	220	12
	31	69	68	116	190	40	93	140	123	M10 x 25	25	190	145	9	10	20	20	25	125	13	20	220	12

Fixing -
 Dimensions -
 Clearing distances -
 Connecting



AM-CC-JORE..21/31 and AMF-CC-JORE..21/31 types R550

Main dimensions mm

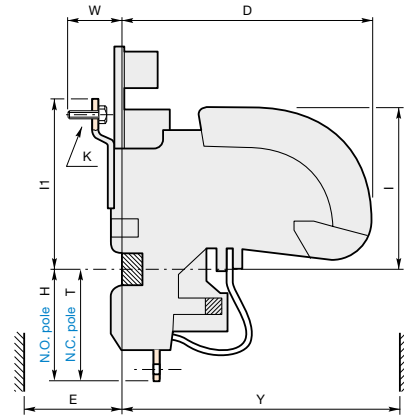
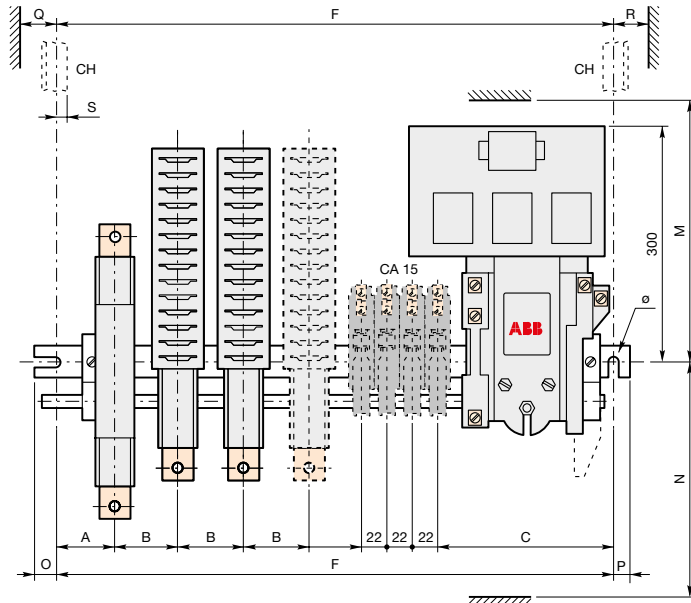

Terminal plate details



Lower terminal plate



Upper terminal plate



AM-CC-JORE..21/31 and AMF-CC-JORE..21/31 types R550

Contactor types	Number of poles	Fixing dimension - F acc. to number of CA15 auxiliary contacts:			Fixing holes
		5	8	12	
R550	21	635	760	760	2 x \varnothing 13
	31	760	760	760	

Contactor types	Number of poles	Dimensions																					
		A	B	C	D	E	H	I	I1	K	ℓ	M	N	O	P	Q	R	S	T	V	W	Y	Z
R550	21	77	80	160	260	100	118	230	195	\varnothing 13	30	313	150	15	14	53	20	20	177	20	46	335	20
	31	77	80	160	260	100	118	230	195	\varnothing 13	30	313	150	15	14	53	20	20	177	20	46	335	20

Fixing -
 Dimensions -
 Clearing distances -
 Connecting



AM-CC-JORE..21 and AM-CC-JORE..31 types R800 ... R2100

Main dimensions mm

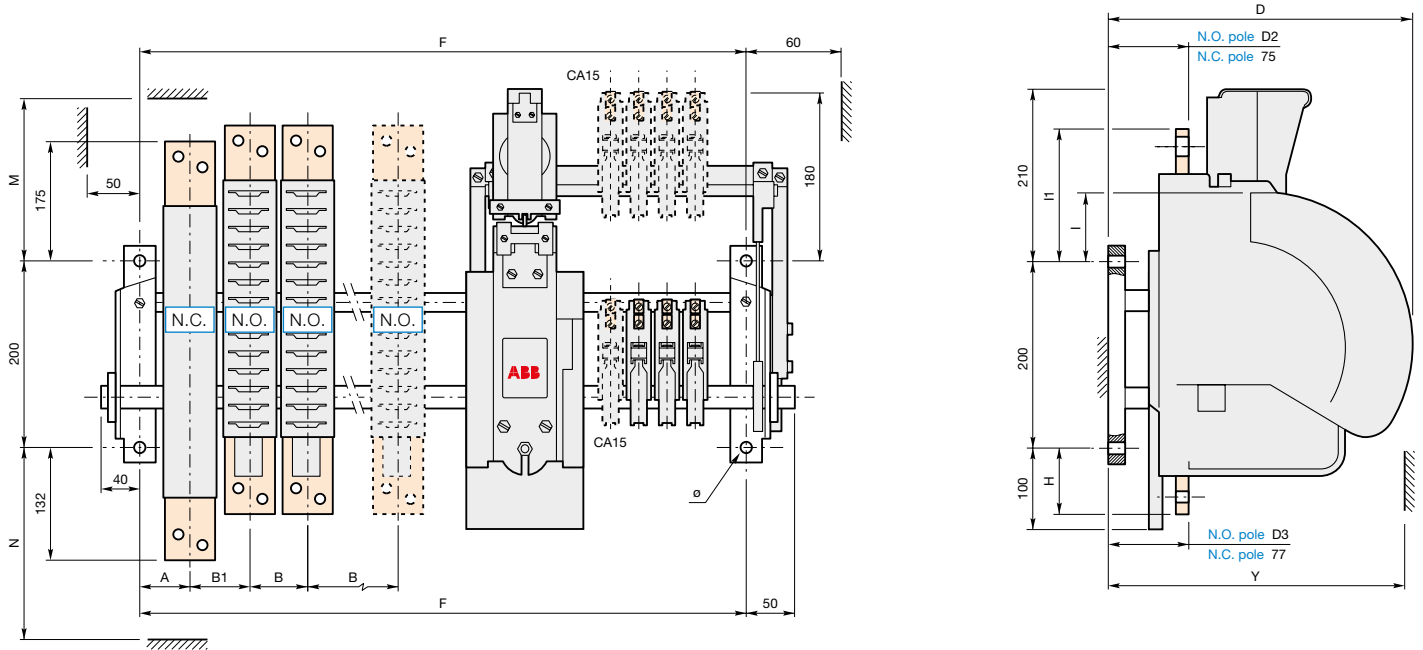

Fig 1 = right electro-magnet (see table in the following page)

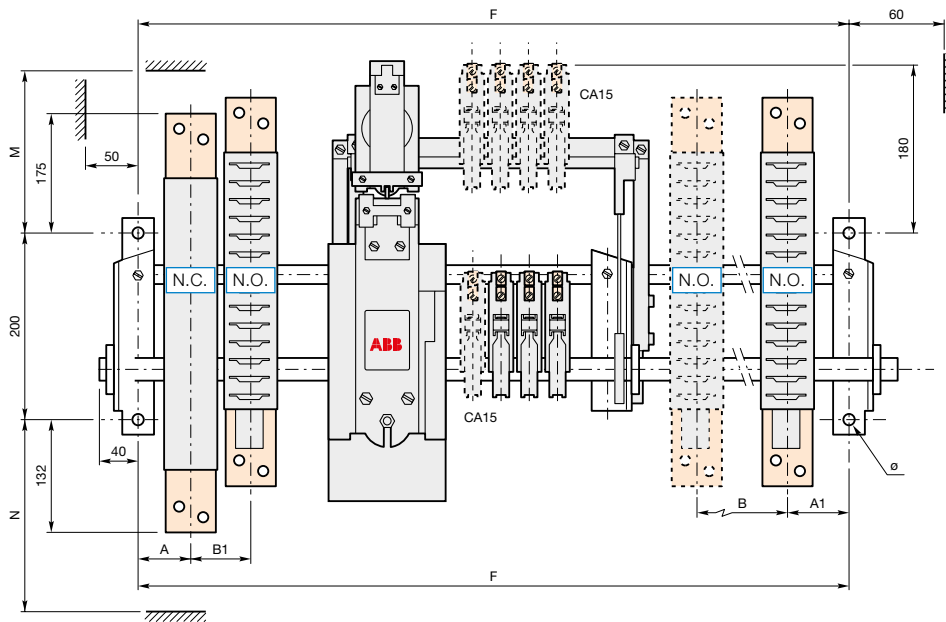
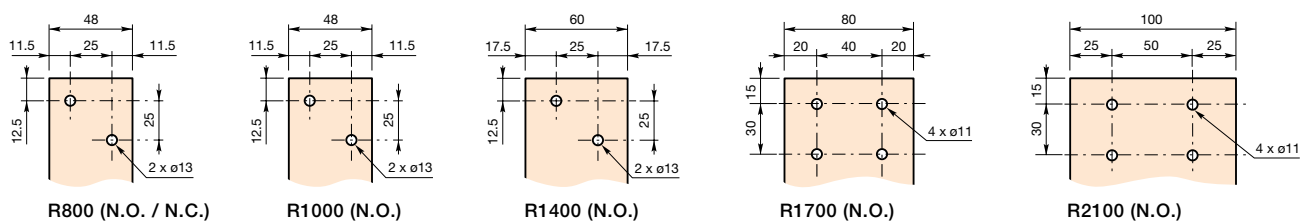

Fig 2 = central electro-magnet (see table in the following page)

Terminal plate details



R800 (N.O. / N.C.)

R1000 (N.O.)

R1400 (N.O.)

R1700 (N.O.)

R2100 (N.O.)

R1000 ... R2100 (N.C.)

Terminal plate thickness: top terminal plates = 10 mm, bottom terminal plates = 12 mm

AM-CC-JORE..21 and AM-CC-JORE..31 types R800 ... R2100

Contactor types	Number of poles	Fixing dimension - F acc. to number of CA15 auxiliary contacts:								Fixing holes ø
		5	6	8	10	12	16	20		
R800	21	540	540	540	570	570	570	570		
	31	540	540	540	640	640	640	640		
R1000	21	550	550	550	650	650	650	650		
	31	650	650	650	760	760	760	760		
R1400	21	550	550	550	650	650	650	650		
	31	650	650	650	760	760	760	760		
R1700	21	635	635	635	760	760	760	760		
	31	820	820	820	920	920	920	920		
R2100	21	635	635	635	760	760	760	760		
	31	820	820	820	920	920	920	920		

Contactor types	Number of poles	Dimensions												
		A	B	B1	D	D2	D3	H	I	I1	M	N	Y	Fig
R800	21	60	70	70	325	75	77	70	108	175	245	152	385	1 or 2
	31	60	70	70	325	75	77	70	108	175	245	152	385	1 or 2
R1000	21	60	100	85	325	76	77	70	108	175	258	152	425	1 or 2
	31	60	100	85	325	76	77	70	108	175	258	152	425	1 or 2
R1400	21	60	100	85	325	76	77	70	108	175	258	152	425	1 or 2
	31	60	100	85	325	76	77	70	108	175	258	152	425	1 or 2
R1700	21	60	140	125	325	89	77	84	108	189	288	152	425	1 or 2
	31	60	120	95	325	89	77	84	108	189	288	152	425	1 or 2
R2100	21	60	140	125	325	89	77	84	108	189	288	152	425	1 or 2
	31	60	120	95	325	89	77	84	108	189	288	152	425	1 or 2

Fixing -
 Dimensions -
 Clearing distances -
 Connecting



AMF-CC-JORE..21 and AMF-CC-JORE..31 types R800 ... R2100

Main dimensions mm

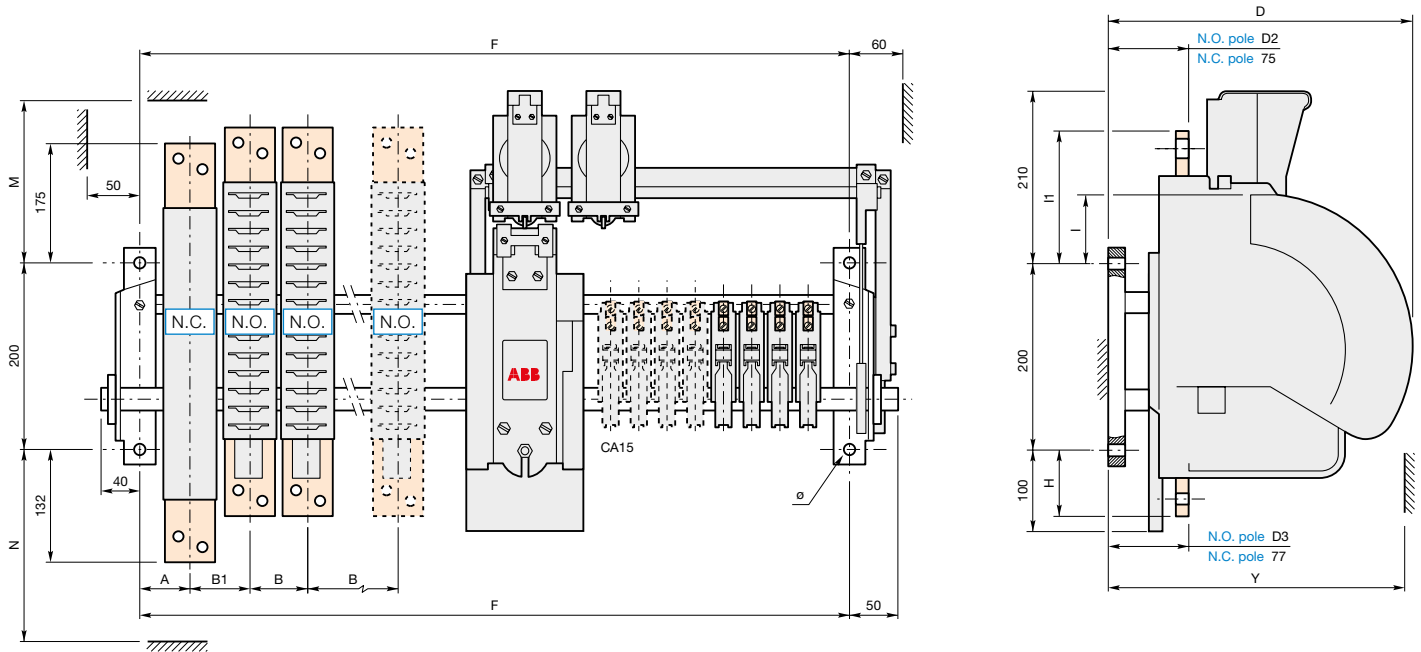

Fig 1 = right electro-magnet (see table in the following page)

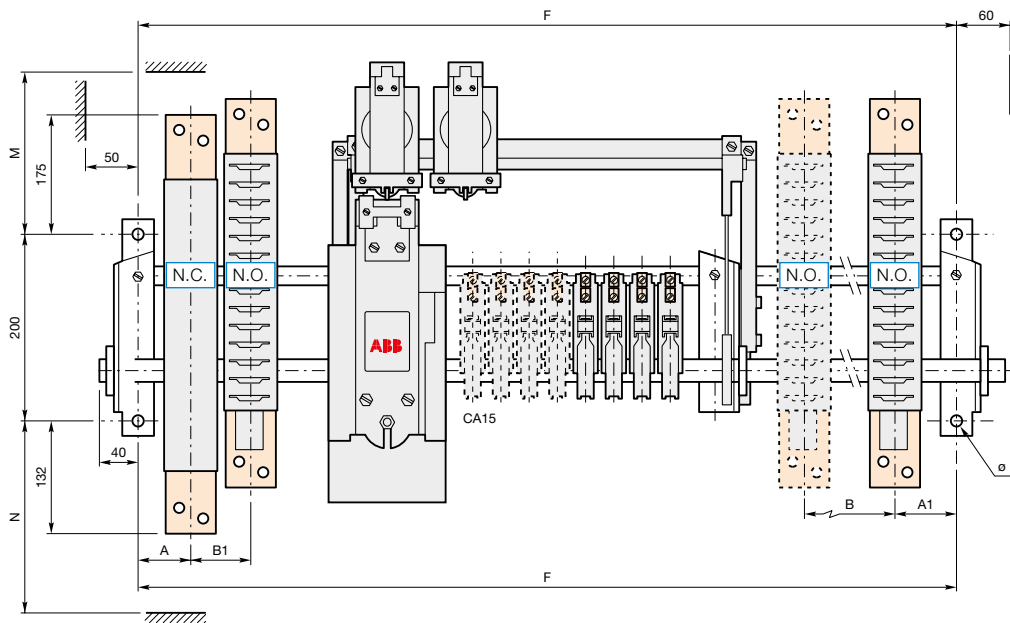
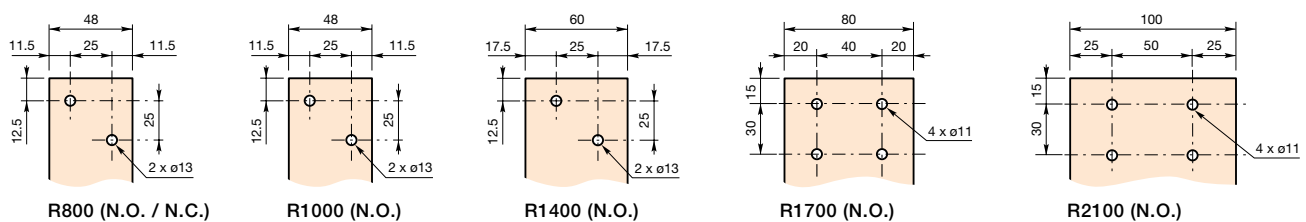

Fig 2 = central electro-magnet (see table in the following page)

Terminal plate details



Terminal plate thickness: top terminal plates = 10 mm, bottom terminal plates = 12 mm

AMF-CC-JORE..21 and AMF-CC-JORE..31 types R800 ... R2100

Contactor types	Number of poles	Fixing dimension - F acc. to number of CA15 auxiliary contacts:						Fixing holes ø
		5	6	8	10	12	16	
R800	21	570	570	570	570	570	570	
	31	640	640	640	640	640	640	
R1000	21	650	650	650	650	650	650	
	31	760	760	760	760	760	760	
R1400	21	650	650	650	650	650	650	
	31	760	760	760	760	760	760	
R1700	21	760	760	760	760	760	760	
	31	920	920	920	920	920	920	
R2100	21	760	760	760	760	760	760	
	31	920	920	920	920	920	920	

Contactor types	Number of poles	Dimensions												
		A	B	B1	D	D2	D3	H	I	I1	M	N	Y	Fig
R800	21	60	70	70	325	75	77	70	108	175	245	152	375	1 or 2
	31	60	70	70	325	75	77	70	108	175	245	152	375	1 or 2
R1000	21	60	100	85	325	76	77	70	108	175	245	152	425	1 or 2
	31	60	100	85	325	76	77	70	108	175	245	152	425	1 or 2
R1400	21	60	100	85	325	76	77	70	108	175	245	152	425	1 or 2
	31	60	100	85	325	76	77	70	108	175	245	152	425	1 or 2
R1700	21	60	140	125	325	89	77	84	108	189	288	152	450	1 or 2
	31	60	120	95	325	89	77	84	108	189	288	152	450	1 or 2
R2100	21	60	140	125	325	89	77	84	108	189	288	152	450	1 or 2
	31	60	120	95	325	89	77	84	108	189	288	152	450	1 or 2

Fixing -
 Dimensions -
 Clearing distances -
 Connecting



AM-CC-JORE..21 and AM-CC-JORE..31 types R2500 ... R4500

Main dimensions mm

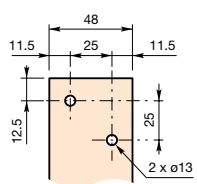
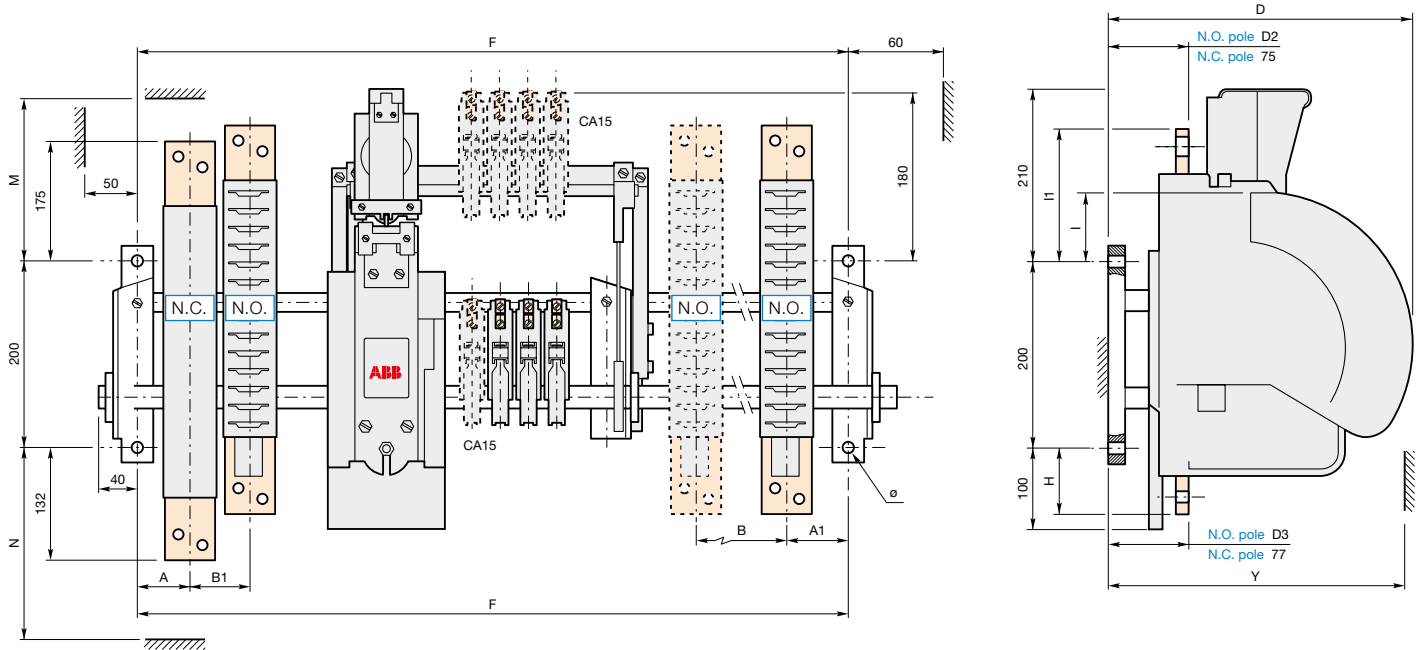

R2500 ... R4500 (N.C.)

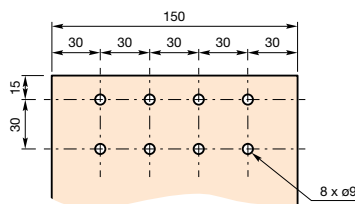

R2500 (N.O.)

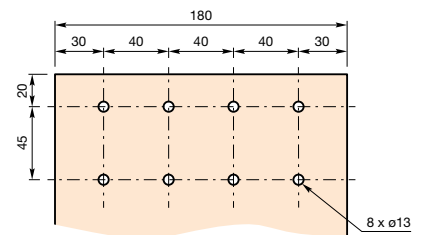

R3200 (N.O.)

Terminal plate thickness for R2500 ... R5100: top and bottom terminal plates = 10 mm

AM-CC-JORE..21 and AM-CC-JORE..31 types R2500 ... R4500

Contactor types	Number of poles	Fixing dimension - F acc. to number of CA15 auxiliary contacts:							Fixing holes ϕ
		5	6	8	10	12	16	20	
R2500	21	885	885	885	985	985	985	985	
	31	1150	1150	1150	1250	1250	1250	1250	
R3200	21	885	885	885	985	985	985	985	
	31	1150	1150	1150	1250	1250	1250	1250	
R3800	21	950	950	950	1050	1050	1050	1050	
	31	1200	1200	1200	1300	1300	1300	1300	
R4500	21	1100	1100	1100	1200	1200	1200	1200	

Contactor types	Number of poles	Dimensions												
		A	A1	B	B1	D	D2	D3	H	I	I1	M	N	Y
R2500	21	60	135	-	145	325	86	87	133	108	238	258	152	425
	31	60	135	220	145	340	101	102	133	108	238	300	215	425
R3200	21	60	135	-	145	325	99	87	174	108	279	300	215	450
	31	60	135	220	145	340	114	102	174	108	279	300	215	450
R3800	21	60	145	-	165	325	99	87	174	108	279	300	215	450
	31	60	145	250	170	340	114	102	174	108	279	300	215	450
R4500	21	60	195	-	200	340	114	102	174	108	279	300	215	450

Fixing -
 Dimensions -
 Clearing distances -
 Connecting

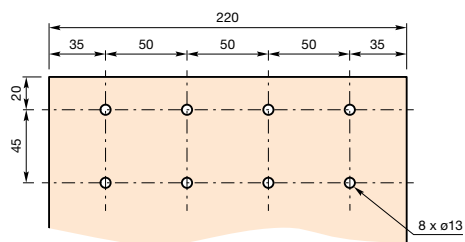

R3800 (N.O.)

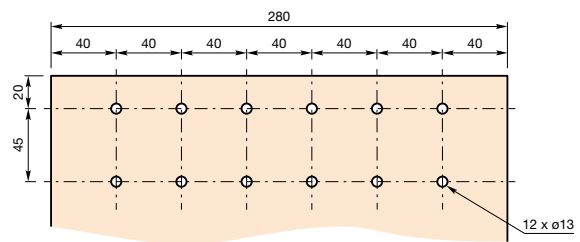

R4500 (N.O.)

Terminal plate thickness for R2500 ... R5100: top and bottom terminal plates = 10 mm

AMF-CC-JORE..21 and AMF-CC-JORE..31 types R2500 ... R4500

Main dimensions mm

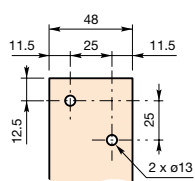
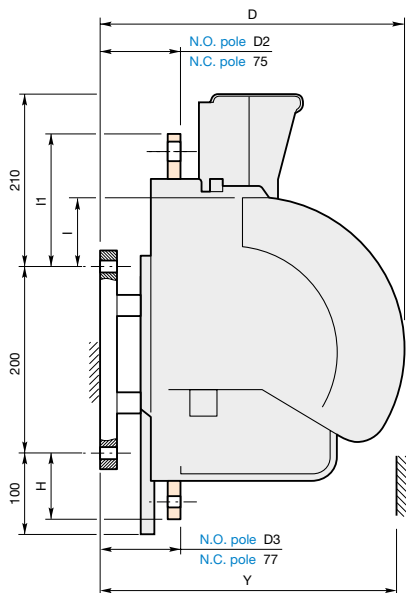
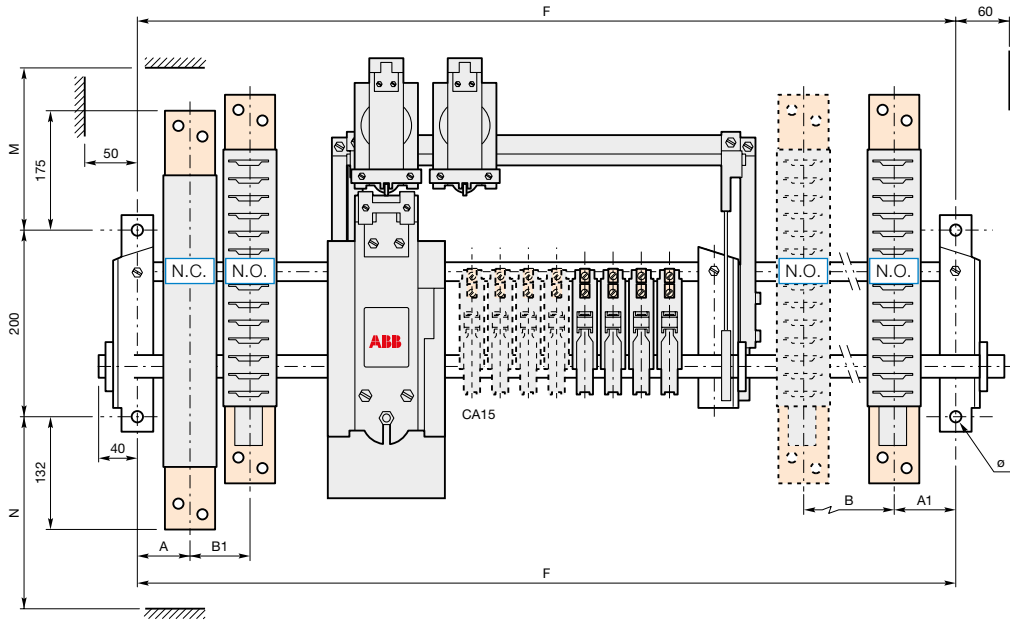

R2500 ... R4500 (N.C.)

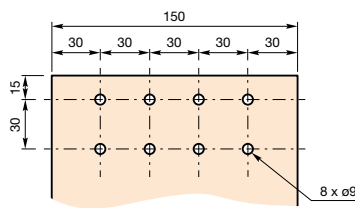

R2500 (N.O.)

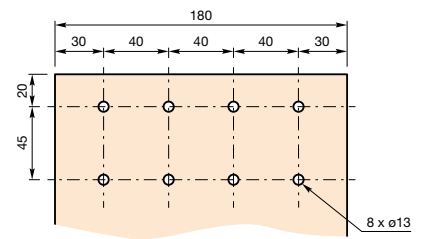

R3200 (N.O.)

Terminal plate thickness for R2500 ... R5100: top and bottom terminal plates = 10 mm

AMF-CC-JORE..21 and AMF-CC-JORE..31 types R2500 ... R4500

Contactor types	Number of poles	Fixing dimension - F acc. to number of CA15 auxiliary contacts:						Fixing holes ø
		5	6	8	10	12	16	
R2500	21	985	985	985	985	985	985	
	31	1250	1250	1250	1250	1250	1250	
R3200	21	985	985	985	985	985	985	
	31	1250	1250	1250	1250	1250	1250	
R3800	21	1050	1050	1050	1050	1050	1050	
	31	1300	1300	1300	1300	1300	1300	
R4500	21	1200	1200	1200	1200	1200	1200	

Contactor types	Number of poles	Dimensions												
		A	A1	B	B1	D	D2	D3	H	I	I1	M	N	Y
R2500	21	60	135	-	145	325	86	87	135	108	238	258	152	425
	31	60	135	-	145	325	86	87	135	108	238	258	152	425
R3200	21	60	135	-	145	325	99	87	174	108	279	300	215	450
	31	60	135	220	145	325	99	87	174	108	279	300	215	450
R3800	21	60	145	-	165	325	99	87	174	108	279	300	215	450
	31	60	145	250	170	325	99	87	174	108	279	300	215	450
R4500	21	60	195	-	200	325	99	87	174	108	279	300	215	450

Fixing -
 Dimensions -
 Clearing distances -
 Connecting

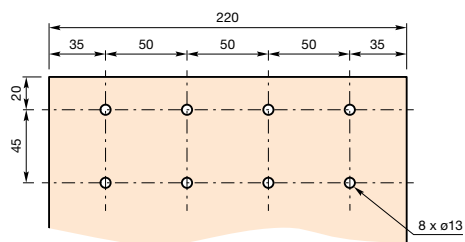

R3800 (N.O.)

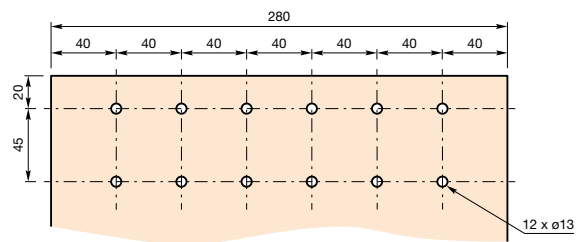

R4500 (N.O.)

Terminal plate thickness for R2500 ... R5100: top and bottom terminal plates = 10 mm



Terms and definition

[Specifications, standards and certifying](#) 10/2

[Terms and technical definitions](#) 10/3

[Utilization categories](#) 10/4

[Climatic withstand of devices](#) 10/6



Specifications, standards and certifying

Definitions

Telarc low voltage devices are developed and manufactured according to the rules set out in IEC international publications and in EN european specifications.

In most countries, low voltage apparatus is built according to such rules with checking being the responsibility of the manufacturer. The devices are therefore not subject to any further obligation for approval. A test report from our laboratories can be remitted to our customers, on request, for presentation to different qualified local organizations.

Prescriptions and standards

International specifications

The International Electrotechnical Commission, IEC, which is part of the International Standards Organization, ISO, publishes IEC publications which act as a basis for the world market.

European specifications and national specifications

The European Committee for Electrotechnical Standardization (CENELEC), which groups together 18 European countries, publishes EN standards. These European standards differ very little from IEC international standards and have similar numbering.

The same applies for national standards which use, without exception, the same numbering and reproduce the texts of these unified standards in their entirety. Contradicting national standards are withdrawn.

European directives

The guarantee of the free movement of goods within the European Community means that any regulatory differences between member states have been eliminated. The European directives set up common rules that are included in the legislation of each state while contradictory regulations are cancelled.

Three directives are essential:

- Low voltage directive 2006/95/EC concerns electrical equipment from 0 to 1000 V AC and from 75 to 1500 V DC
- This specifies that compliance with the requirements that it sets out is acquired if the equipment conforms to the standards harmonized on a european level: EN 60947-1 and EN 60947-4-1 for contactors
- Machines directive 2006/42/EC for safety specifications of machines and equipment on complete machines. Machines bearing the ce mark comply with these specifications
- Electromagnetic compatibility directive 2004/108/EC which concerns all devices able to create electromagnetic disturbance
- Standard EN 60947-4-1 does not set out any requirement concerning the level of emission or immunity of contactors which do not have any active electronic components. Owing to this fact, compliance with standard EN 60947-4-1 meets the requirements for ce marking, with respect to this directive.

CE Marking :

- must not be confused with a quality label
- is proof of conformity with the European Directives concerning the product
- is part of an administrative procedure and guarantees free movement of the product within the European Community.

International standards

- | | |
|---------------|---|
| IEC 60947-1 | Low-voltage switchgear and controlgear – Part 1: General rules. |
| IEC 60947-4-1 | Low-voltage switchgear and controlgear – Part 4: Contactors and motor starters.
Section 1: Electromechanical contactors and motor starters. |
| IEC 60947-5-1 | Low-voltage switchgear and controlgear – Part 5: Control circuit devices and switching elements.
Section 1: Electromechanical control circuit devices. |

European standards

- | | |
|--------------|---|
| EN 60947-1 | Low-voltage switchgear and controlgear – Part 1: General rules. |
| EN 60947-4-1 | Low-voltage switchgear and controlgear – Part 4: Contactors and motor starters.
Section 1: Electromechanical contactors and motor starters. |
| EN 60947-5-1 | Low-voltage switchgear and controlgear – Part 5: Control circuit devices and switching elements.
Section 1: Electromechanical control circuit devices. |



Terms and technical definitions

Terminology

Altitude

Characterizes the place of use. It is expressed in metres above sea level.

Circuits

- Auxiliary circuit:
All the conductive parts of a contactor designed to be inserted in a different circuit from the main circuit and the contactor control circuits.
- Control circuit:
All the conductive parts of a contactor (other than the main circuit and the auxiliary circuit) used to control the contactor's closing operation or opening operation or both.
- Main circuit:
All the conductive parts of a contactor designed to be inserted in the circuit that it controls.

Rated operational current I_e

Current rated by the manufacturer. It is mainly based on the rated operational voltage U_e , the rated frequency, the utilization category, the rated duty and the type of protective enclosure, if necessary.

Conventional free air thermal current I_{th}

Current that the contactor can withstand in free air for a duty time of 8 hours without the temperature rise of its various parts exceeding the maximum values given by the standard.

Electrical durability

Number of on-load operating cycles that the contactor is able to carry out. It depends on the utilization category.

Mechanical durability

Number of no-current operating cycles that a contactor is able to carry out.

Switching frequency

Number of switching cycles per hour.

Coil operating limits

Expressed in multiples of the nominal control circuit voltage U_c for the upper and lower limits.

Mounting position

Comply with the manufacturer's instructions.

Rated breaking or making capacity

Root mean square value (R.M.S.) Of the current that the contactor is able to break or make at a given voltage according to the conditions specified by standards and for a given utilization category.

Ambient temperature

Air temperature close to the contactor.

Time

- Time constant :
Ratio of the inductance to the resistance ($L/R = \text{mh}/\Omega = \text{ms}$).
- Short-time withstand current I_{cw} :
Current that the contactor is able to withstand in closed position for a short time interval and in specified conditions.
- Minimum switching time:
This is the minimum closing or opening order time necessary for the contactor to reach complete closing or opening.
- Closing time:
Time interval between the beginning of the closing operation and the instant the contacts touch on all the poles.
- Opening time:
Time interval between the specified starting instant of the opening operation and the instant the arcing contacts separate on all the poles.

Rated control voltage U_c

Control voltage value for which the control circuit is sized.

Rated operational voltage U_e

Voltage to which the contactor's utilization characteristics refer. In three-phase it is the phase-to-phase voltage.

Rated insulation voltage U_i

Reference voltage for dielectric tests and creepage distances.

Rated impulse withstand voltage U_{imp}

Peak value of an impulse voltage, having a specified form and polarity, which does not cause breakdown in specific test conditions.

Shock withstand

Requirement for vehicles, crane drives, installations on board ships and plug-in equipment. The contactors must not change position and the overload relays must not trip.

Resistance to vibrations

Requirements for vehicles, boats and other means of transport. For the specified vibration amplitude and frequency values the device must remain able to operate.



Utilization categories

Standards

IEC publications 60941-1, 60947-4-1 and 60947-5-1 should be referred to on an international level with respect to contactors.

A contactor's duty is characterised by the utilization category together with the rated operational voltage and current indicated.

Utilization categories for contactors according to IEC 60947-4-1

Alternating current:

- **AC-1** Non-inductive or slightly inductive loads, resistance furnaces
- **AC-2** Slip-ring motors: starting, switching off
- **AC-3** Cage motors: starting, switching off running motors
- **AC-4** Cage motors: starting, plugging, inching
- **AC-5a** Discharge lamp switching
- **AC-5b** Incandescent lamp switching
- **AC-6a** Transformer switching
- **AC-6b** Capacitor bank switching
- **AC-7a** Slightly inductive loads for domestic devices and similar applications
- **AC-7b** Motors for domestic applications
- **AC-8a** Hermetic refrigeration compressor motor control with manual resetting of overload releases
- **AC-8b** Hermetic refrigeration compressor motor control with automatic resetting of overload releases.

Direct current:

- **DC-1** Non inductive or slightly inductive loads, resistance furnaces
- **DC-3** Shunt motors: starting, plugging, inching, dynamic breaking of DC motors
- **DC-5** Series motors: starting, plugging, inching, dynamic breaking of DC motors
- **DC-6** Incandescent lamp switching.

Utilization categories for the auxiliary contacts according to IEC 60947-5-1

Alternating current:

- **AC-12** Control of resistive loads and static loads with opto-coupler isolation
- **AC-13** Control of static loads with transformer isolation
- **AC-14** Control of weak electromagnetic loads (≤ 72 VA)
- **AC-15** Control of electromagnetic loads (> 72 VA).

Direct current:

- **DC-12** Control of resistive loads and static loads with opto-coupler isolation
- **DC-13** Control of DC electromagnets
- **DC-14** Control of DC electromagnets having economy resistors.

In fact some applications, and the specific criteria characterizing the various loads controlled by contactors, may modify the utilization characteristics of the contactors.

DC power circuit switching

Arc suppression is more difficult in direct current than in alternating current and this is all the more true the higher the circuit time constant which is why it is necessary to connect several poles in series in order to improve breaking conditions.

AC high current circuit switching

Possibility of increasing performances by connecting poles in parallel (please consult us).

Influence of the length of the conductors used in the contactor control circuit

According to the operational voltages and the coil consumption, take line resistances and capacitances into consideration, for the length and the cross-sectional of the conductors.



Utilization categories

Making and breaking conditions for utilization categories

Utilization category	Durability test conditions						Occasional operation					
	Making conditions			Breaking conditions			Making conditions			Breaking conditions		
	I/le	U/Ue	Cos. φ or L/R (ms)	I/le	U/Ue	Cos. φ or L/R (ms)	Ic/le	Ur/Ue	Cos. φ or L/R (ms)	Ic/le	Ur/Ue	Cos. φ or L/R (ms)

Contactors for AC circuit switching

AC-1	1	1	0.95	1	1	0.95	1.5	1.05	0.8	1.5	1.05	0.8	
AC-2	2.5	1	0.65	2.5	1	0.65	4	1.05	0.65	4	1.05	0.65	
AC-3	le ≤ 100 A	6	1	0.35	1	0.17	0.35	10	1.05	0.45	8	1.05	0.45
	le > 100 A	6	1	0.35	1	0.17	0.35	10	1.05	0.35	8	1.05	0.35
AC-4	le ≤ 100 A	6	1	0.35	6	1	0.35	12	1.05	0.45	10	1.05	0.45
	le > 100 A	6	1	0.35	6	1	0.35	12	1.05	0.35	10	1.05	0.35

Contactors for DC circuit switching

DC-1	1	1	1	1	1	1	1.5	1.05	1	1.5	1.05	1
DC-3	2.5	1	2	2.5	1	2	4	1.05	2.5	4	1.05	2.5
DC-5	2.5	1	7.5	2.5	1	7.5	4	1.05	15	4	1.05	15

Auxiliary contacts for AC circuit switching

AC-14 (≤ 72 VA)	-	-	-	-	-	-	6	1.1	0.7	6	1.1	0.7
AC-15 (> 72 VA)	10	1	0.7	1	1	0.4	10	1.1	0.3	10	1.1	0.3

Auxiliary contacts for DC circuit switching

Utilization category	Standard operation						Occasional operation					
	Making conditions			Breaking conditions			Making conditions			Breaking conditions		
	I/le	U/Ue	T0.95	I/le	U/Ue	T0.95	I/le	U/Ue	T0.95	I/le	U/Ue	T0.95
DC-13	1	1	6 P (1)	1	1	6 P (1)	1.1	1.1	6 P (1)	1.1	1.1	6 P (1)
DC-14	-	-	-	-	-	-	10	1.1	15 ms	10	1.1	15 ms

(1) The value "6 x P" is the result of an empirical relation which is estimated to represent most DC magnetic loads up to the highest limit of P = 50 W (6 x P = 300 ms). It is accepted that loads having drawn energy above 50 W are made up of weaker loads in parallel. As a consequence, the 300 ms value must form the highest limit whatever the value of the power drawn.

Key:

U (I) = applied voltage (current)

Ur = recovery voltage

L/R = test circuit time constant

Ue (Ie) = rated operational voltage (current)

Ic = making and breaking current expressed in DC or in AC like the r.m.s. value of the symmetrical components

T0.95 = time required to reach 95 % of the current in steady-state conditions, expressed in milliseconds

Climatic withstand of devices

General

The life time and dependability of devices are mainly influenced by a series of climatic factors which cause their corrosion.

In practice, besides climatic conditions, there are other factors which may damage equipment such as fungi, insects (termites), dust, work site dirt and aggressive environment (salty or sulphurous atmosphere, etc.) which can often only be identified at the place of installation.

The entrance of dust, insects, dirt, etc. in devices may be prevented if the appropriate degree of protection according to IEC 60529 is chosen.

Telarc contactors have been used for many years in the most varied countries, with hot and humid climates for example: Brazil, Indonesia, India etc. Experience has shown that Telarc devices can be used in most countries throughout the world.

The climate of the country in which the device is installed is not the determining choice factor.

Account must be taken of:

- the immediate environment of the devices (sheltered, ventilated, temperature)
- the aggressivity of the immediate atmosphere at the place of installation
- the length and frequency of non operating periods.

In the case of frequent condensation (ie the formation of steam caused by rapid changes in temperature), heating resistors must be installed in cubicles (100 to 250 W per m³ of enclosure).

The table below gives the cases where heating is necessary.

Environment		Operating conditions	Climate	Internal heating of enclosure
Inside premises	no running water, no condensation	Continuous or not	All climates	Without
	with running water	Continuous	All climates	Without
		Frequent or long stops	Temperate	Without
			Tropical	With
Outside, sheltered	no running water, no condensation	Continuous or not	Temperate	Without
			Tropical	With
Outside or by the seaside	with running water	Continuous	All climates	Without
		Frequent or long stops	Temperate	Without
			Tropical	With



The standard R series contactors are suitable for industrial environment and tropical atmospheres.

Notes

Area with horizontal dotted lines for writing notes.



Questionnaire

Specification for R contactors

Customer
 Contact person Date
 Tel. e-mail

Telarc
 Contact person
 Tel.

Quantity Requested delivery date
 Project / Application

Power circuit

AC switching

Application type

- AC-1 (resistive load)
- AC-3 (direct starting, switching off running motors)
- No load breaking
- Other

Number of poles: N.O. N.C.

Rated operational current I_e A

Max. making current A

Max. breaking current A

Rated operational voltage U_e V Hz

or

DC switching

Application type

- DC-1 (resistive load)
- DC-3 (shunt motors)
- DC-5 (series motors)
- No load breaking
- Other L/R ms

Number of poles: N.O. N.C.

Rated operational current I_e A

Making current A

Breaking current min. A max. A

Rated operational voltage U_e V DC

Operating conditions

Switching frequency cycles/h

Mech. durability required (millions of operating cycles)

Remarks

Auxiliary contacts

Number of N.O. auxiliary contacts

Number of N.C. auxiliary contacts

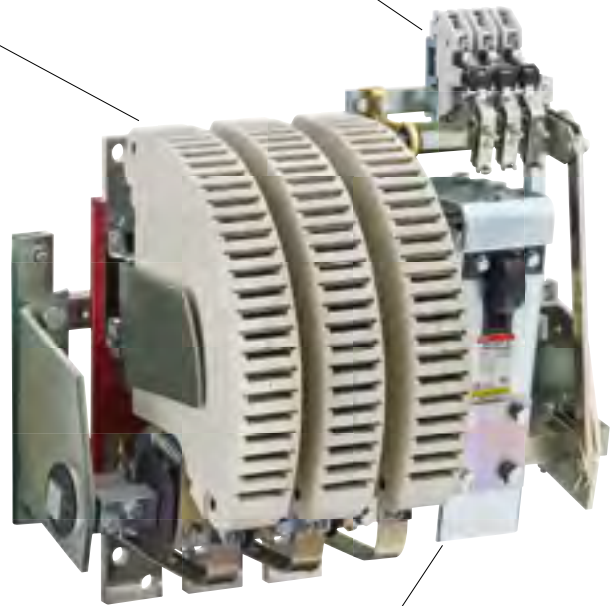

Control circuit (coil)

AC Voltage V Hz

DC Voltage V DC

Options

- Latching (magnetical or mechanical latching acc. to contactor rating)

Accessories

Please add any other useful documents for further information e.g. technical specification, drawing, wiring diagram, etc.

Replacement of an existing contactor

Brand

Type

Fixing dimension F = mm

Overall dimensions W = mm

H = mm

D = mm

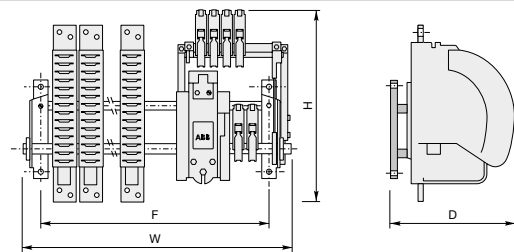

Index

Order code classification

Order code	Type	Page
FPL6110115R0006	IORE1400-10-CC	4/5
FPL6110125R0116	IORE1400-10-CC-AME	4/9
FPL6110195R0006	IORE1400-10-CC-U	4/7
FPL6110215R0006	IORE1400-20-CC	4/5
FPL6110225R0116	IORE1400-20-CC-AME	4/9
FPL6110315R0006	IORE1400-30-CC	4/5
FPL6110325R0116	IORE1400-30-CC-AME	4/9
FPL6115215R0006	IORR1400-20	3/4
FPL6115225R0116	IORR1400-20-AME	3/8
FPL6115315R0006	IORR1400-30	3/4
FPL6115325R0116	IORR1400-30-AME	3/8
FPL6115415R0006	IORR1400-40	3/4
FPL6115425R0116	IORR1400-40-AME	3/8
FPL6116115R0006	IORR1400-10-CC	4/4
FPL6116125R0116	IORR1400-10-CC-AME	4/8
FPL6116195R0006	IORR1400-10-CC-U	4/6
FPL6116215R0006	IORR1400-20-CC	4/4
FPL6116225R0116	IORR1400-20-CC-AME	4/8
FPL6116315R0006	IORR1400-30-CC	4/4
FPL6116325R0116	IORR1400-30-CC-AME	4/8
FPL6119215R0006	IORE1400-20	3/5
FPL6119225R0116	IORE1400-20-AME	3/9
FPL6119315R0006	IORE1400-30	3/5
FPL6119325R0116	IORE1400-30-AME	3/9
FPL6119415R0006	IORE1400-40	3/5
FPL6119425R0116	IORE1400-40-AME	3/9
FPL6125215R0006	IORR1400-20-MT	3/6
FPL6125225R0116	IORR1400-20-MT-AME	3/10
FPL6125315R0006	IORR1400-30-MT	3/6
FPL6125325R0116	IORR1400-30-MT-AME	3/10
FPL6125415R0006	IORR1400-40-MT	3/6
FPL6129215R0006	IORE1400-20	3/7
FPL6129225R0116	IORE1400-20-MT-AME	3/11
FPL6129315R0006	IORE1400-30-MT	3/7
FPL6129325R0116	IORE1400-30-MT-AME	3/11
FPL6129415R0006	IORE1400-40-MT	3/7
FPL6135110R0006	LORR1400-10	5/8
FPL6135210R0006	LORR1400-20	5/8
FPL6135310R0006	LORR1400-30	5/8
FPL6135410R0006	LORR1400-40	5/8
FPL6139110R0006	LORE1400-10	5/9
FPL6139210R0006	LORE1400-20	5/9
FPL6139310R0006	LORE1400-30	5/9
FPL6139410R0006	LORE1400-40	5/9
FPL6210125R0116	IORE1700-10-CC-AME	4/9
FPL6210185R0006	IORE1700-10-CC	4/5
FPL6210195R0006	IORE1700-10-CC-U	4/7
FPL6210215R0006	IORE1700-20-CC	4/5
FPL6210225R0116	IORE1700-20-CC-AME	4/9
FPL6210315R0006	IORE1700-30-CC	4/5
FPL6210325R0116	IORE1700-30-CC-AME	4/9
FPL6215215R0006	IORR1700-20	3/4
FPL6215225R0116	IORR1700-20-AME	3/8
FPL6215315R0006	IORR1700-30	3/4
FPL6215325R0116	IORR1700-30-AME	3/8
FPL6215415R0006	IORR1700-40	3/4
FPL6215425R0116	IORR1700-40-AME	3/8
FPL6216125R0116	IORR1700-10-CC-AME	4/8
FPL6216185R0006	IORR1700-10-CC	4/4
FPL6216195R0006	IORR1700-10-CC-U	4/6
FPL6216215R0006	IORR1700-20-CC	4/4
FPL6216225R0116	IORR1700-20-CC-AME	4/8
FPL6216315R0006	IORR1700-30-CC	4/4
FPL6216325R0116	IORR1700-30-CC-AME	4/8
FPL6219215R0006	IORE1700-20	3/5
FPL6219225R0116	IORE1700-20-AME	3/9
FPL6219315R0006	IORE1700-30	3/5
FPL6219325R0116	IORE1700-30-AME	3/9
FPL6219415R0006	IORE1700-40	3/5
FPL6219425R0116	IORE1700-40-AME	3/9
FPL6225215R0006	IORR1700-20-MT	3/6
FPL6225225R0116	IORR1700-20-MT-AME	3/10
FPL6225315R0006	IORR1700-30-MT	3/6

Order code	Type	Page
FPL6225325R0116	IORR1700-30-MT-AME	3/10
FPL6225415R0006	IORR1700-40-MT	3/6
FPL6229215R0006	IORE1700-20-MT	3/7
FPL6229225R0116	IORE1700-20-MT-AME	3/11
FPL6229315R0006	IORE1700-30-MT	3/7
FPL6229325R0116	IORE1700-30-MT-AME	3/11
FPL6229415R0006	IORE1700-40-MT	3/7
FPL6235110R0006	LORR1700-10	5/8
FPL6235210R0006	LORR1700-20	5/8
FPL6235310R0006	LORR1700-30	5/8
FPL6235410R0006	LORR1700-40	5/8
FPL6239110R0006	LORE1700-10	5/9
FPL6239210R0006	LORE1700-20	5/9
FPL6239310R0006	LORE1700-30	5/9
FPL6239410R0006	LORE1700-40	5/9
FPL6310125R0116	IORE2100-10-CC-AME	4/9
FPL6310185R0006	IORE2100-10-CC	4/5
FPL6310195R0006	IORE2100-10-CC-U	4/7
FPL6310215R0006	IORE2100-20-CC	4/5
FPL6310225R0116	IORE2100-20-CC-AME	4/9
FPL6310315R0006	IORE2100-30-CC	4/5
FPL6310325R0116	IORE2100-30-CC-AME	4/9
FPL6315215R0006	IORR2100-20	3/4
FPL6315225R0116	IORR2100-20-AME	3/8
FPL6315315R0006	IORR2100-30	3/4
FPL6315325R0116	IORR2100-30-AME	3/8
FPL6315415R0006	IORR2100-40	3/4
FPL6315425R0116	IORR2100-40-AME	3/8
FPL6316125R0116	IORR2100-10-CC-AME	4/8
FPL6316185R0006	IORR2100-10-CC	4/4
FPL6316195R0006	IORR2100-10-CC-U	4/6
FPL6316215R0006	IORR2100-20-CC	4/4
FPL6316225R0116	IORR2100-20-CC-AME	4/8
FPL6316315R0006	IORR2100-30-CC	4/4
FPL6316325R0116	IORR2100-30-CC-AME	4/8
FPL6319215R0006	IORE2100-20	3/5
FPL6319225R0116	IORE2100-20-AME	3/9
FPL6319315R0006	IORE2100-30	3/5
FPL6319325R0116	IORE2100-30-AME	3/9
FPL6319415R0006	IORE2100-40	3/5
FPL6319425R0116	IORE2100-40-AME	3/9
FPL6325215R0006	IORR2100-20-MT	3/6
FPL6325225R0116	IORR2100-20-MT-AME	3/10
FPL6325315R0006	IORR2100-30-MT	3/6
FPL6325325R0116	IORR2100-30-MT-AME	3/10
FPL6325415R0006	IORR2100-40-MT	3/6
FPL6329215R0006	IORE2100-20-MT	3/7
FPL6329225R0116	IORE2100-20-MT-AME	3/11
FPL6329315R0006	IORE2100-30-MT	3/7
FPL6329325R0116	IORE2100-30-MT-AME	3/11
FPL6329415R0006	IORE2100-40-MT	3/7
FPL6335110R0006	LORR2100-10	5/8
FPL6335210R0006	LORR2100-20	5/8
FPL6335310R0006	LORR2100-30	5/8
FPL6335410R0006	LORR2100-40	5/8
FPL6339110R0006	LORE2100-10	5/9
FPL6339210R0006	LORE2100-20	5/9
FPL6339310R0006	LORE2100-30	5/9
FPL6339410R0006	LORE2100-40	5/9
FPL6510115R0006	IORE3200-10-CC	4/5
FPL6510125R0116	IORE3200-10-CC-AME	4/9
FPL6510215R0006	IORE3200-20-CC	4/5
FPL6510225R0116	IORE3200-20-CC-AME	4/9
FPL6510315R0006	IORE3200-30-CC	4/5
FPL6510325R0116	IORE3200-30-CC-AME	4/9
FPL6515215R0006	IORR3200-20	3/4
FPL6515225R0116	IORR3200-20-AME	3/8
FPL6515315R0006	IORR3200-30	3/4
FPL6515325R0116	IORR3200-30-AME	3/8
FPL6516115R0006	IORR3200-10-CC	4/4
FPL6516125R0116	IORR3200-10-CC-AME	4/8
FPL6516215R0006	IORR3200-20-CC	4/4
FPL6516225R0116	IORR3200-20-CC-AME	4/8

Order code	Type	Page
FPL6516315R0006	IORR3200-30-CC	4/4
FPL6516325R0116	IORR3200-30-CC-AME	4/8
FPL6519215R0006	IORE3200-20	3/5
FPL6519225R0116	IORE3200-20-AME	3/9
FPL6519315R0006	IORE3200-30	3/5
FPL6519325R0116	IORE3200-30-AME	3/9
FPL6525215R0006	IORR3200-20-MT	3/6
FPL6525225R0116	IORR3200-20-MT-AME	3/10
FPL6525315R0006	IORR3200-30-MT	3/6
FPL6525325R0116	IORR3200-30-MT-AME	3/10
FPL6529215R0006	IORE3200-20-MT	3/7
FPL6529225R0116	IORE3200-20-MT-AME	3/11
FPL6529315R0006	IORE3200-30-MT	3/7
FPL6529325R0116	IORE3200-30-MT-AME	3/11
FPL6535001R0006	LORR3200-40	5/8
FPL6535110R0006	LORR3200-10	5/8
FPL6535210R0006	LORR3200-20	5/8
FPL6535310R0006	LORR3200-30	5/8
FPL6539001R0006	LORE3200-40	5/9
FPL6539110R0006	LORE3200-10	5/9
FPL6539210R0006	LORE3200-20	5/9
FPL6591310R0006	LORE3200-30	5/9
FPL6610115R0006	IORE3800-10-CC	4/5
FPL6610125R0116	IORE3800-10-CC-AME	4/9
FPL6610215R0006	IORE3800-20-CC	4/5
FPL6610225R0116	IORE3800-20-CC-AME	4/9
FPL6615001R0006	IORR3800-30	3/4
FPL6615215R0006	IORR3800-20	3/4
FPL6615225R0116	IORR3800-20-AME	3/8
FPL6616115R0006	IORR3800-10-CC	4/4
FPL6616125R0116	IORR3800-10-CC-AME	4/8
FPL6616215R0006	IORR3800-20-CC	4/4
FPL6616225R0116	IORR3800-20-CC-AME	4/8
FPL6619001R0006	IORE3800-30	3/5
FPL6619215R0006	IORE3800-20	3/5
FPL6619225R0116	IORE3800-20-AME	3/9
FPL6625001R0006	IORR3800-30-MT	3/6
FPL6625215R0006	IORR3800-20-MT	3/6
FPL6625225R0116	IORR3800-20-MT-AME	3/10
FPL6625325R0116	IORR3800-30-MT-AME	3/10
FPL6629001R0006	IORE3800-30-MT	3/7
FPL6629215R0006	IORE3800-20-MT	3/7
FPL6629225R0116	IORE3800-20-MT-AME	3/11
FPL6629325R0116	IORE3800-30-MT-AME	3/11
FPL6635002R0006	LORR3800-30	5/8
FPL6635003R0006	LORR3800-40	5/8
FPL6635110R0006	LORR3800-10	5/8
FPL6635210R0006	LORR3800-20	5/8
FPL6639002R0006	LORE3800-30	5/9
FPL6639003R0006	LORE3800-40	5/9
FPL6639110R0006	LORE3800-10	5/9
FPL6639210R0006	LORE3800-20	5/9
FPL6710115R0006	IORE2500-10-CC	4/5
FPL6710125R0116	IORE2500-10-CC-AME	4/9
FPL6710215R0006	IORE2500-20-CC	4/5
FPL6710225R0116	IORE2500-20-CC-AME	4/9
FPL6710315R0006	IORE2500-30-CC	4/5
FPL6710325R0116	IORE2500-30-CC-AME	4/9
FPL6715215R0006	IORR2500-20	3/4
FPL6715225R0116	IORR2500-20-AME	3/8
FPL6715315R0006	IORR2500-30	3/4
FPL6715325R0116	IORR2500-30-AME	3/8
FPL6716115R0006	IORR2500-10-CC	4/4
FPL6716125R0116	IORR2500-10-CC-AME	4/8
FPL6716215R0006	IORR2500-20-CC	4/4
FPL6716225R0116	IORR2500-20-CC-AME	4/8
FPL6716315R0006	IORR2500-30-CC	4/4
FPL6716325R0116	IORR2500-30-CC-AME	4/8
FPL6719215R0006	IORE2500-20	3/5
FPL6719225R0116	IORE2500-20-AME	3/9
FPL6719315R0006	IORE2500-30	3/5
FPL6719325R0116	IORE2500-30-AME	3/9
FPL6725215R0006	IORR2500-20-MT	3/6



CHS Controls AB
 Tel +46 42 38 61 00, Fax +46 42 38 61 29
 chs@chscontrols.se www.chscontrols.se

Index

Order code classification

Order code	Type	Page
FPL672525R0116	IORR2500-20-MT-AME	3/10
FPL6725315R0006	IORR2500-30-MT	3/6
FPL6725325R0116	IORR2500-30-MT-AME	3/10
FPL6725415R0006	IORR2500-40-MT	3/6
FPL6729215R0006	IORE2500-20-MT	3/7
FPL6729225R0116	IORE2500-20-MT-AME	3/11
FPL6729315R0006	IORE2500-30-MT	3/7
FPL6729325R0116	IORE2500-30-MT-AME	3/11
FPL6729415R0006	IORE2500-40-MT	3/7
FPL6735110R0006	LORR2500-10	5/8
FPL6735210R0006	LORR2500-20	5/8
FPL6735310R0006	LORR2500-30	5/8
FPL6735410R0006	LORR2500-40	5/8
FPL6739110R0006	LORE2500-10	5/9
FPL6739210R0006	LORE2500-20	5/9
FPL6739310R0006	LORE2500-30	5/9
FPL6739410R0006	LORE2500-40	5/9
FPL6810115R0006	IORE4500-10-CC	4/5
FPL6810125R0116	IORE4500-10-CC-AME	4/9
FPL6810215R0006	IORE4500-20-CC	4/5
FPL6810225R0116	IORE4500-20-CC-AME	4/9
FPL6815001R0006	IORR4500-30	3/4
FPL6815215R0006	IORR4500-20	3/4
FPL6815225R0116	IORR4500-20-AME	3/8
FPL6816115R0006	IORR4500-10-CC	4/4
FPL6816125R0116	IORR4500-10-CC-AME	4/8
FPL6816215R0006	IORR4500-20-CC	4/4
FPL6816225R0116	IORR4500-20-CC-AME	4/8
FPL6819001R0006	IORE4500-30	3/5
FPL6819215R0006	IORE4500-20	3/5
FPL6819225R0116	IORE4500-20-AME	3/9
FPL6825002R0006	IORR4500-30-MT	3/6
FPL6825215R0006	IORR4500-20-MT	3/6
FPL6825225R0116	IORR4500-20-MT-AME	3/10
FPL6829001R0006	IORE4500-30-MT	3/7
FPL6829215R0006	IORE4500-20-MT	3/7
FPL6829225R0116	IORE4500-20-MT-AME	3/11
FPL6835001R0006	LORR4500-30	5/8
FPL6835110R0006	LORR4500-10	5/8
FPL6835210R0006	LORR4500-20	5/8
FPL6839001R0006	LORE4500-30	5/9
FPL6839110R0006	LORE4500-10	5/9
FPL6839210R0006	LORE4500-20	5/9
FPL6910115R0006	IORE5100-10-CC	4/5
FPL6910125R0116	IORE5100-10-CC-AME	4/9
FPL6915001R0006	IORR5100-20	3/4
FPL6915002R0006	IORR5100-30	3/4
FPL6916115R0006	IORR5100-10-CC	4/4
FPL6916125R0116	IORR5100-10-CC-AME	4/8
FPL6919001R0006	IORE5100-20	3/5
FPL6919002R0006	IORE5100-30	3/5
FPL6925001R0006	IORR5100-20-MT	3/6
FPL6925002R0006	IORR5100-30-MT	3/6
FPL6929001R0006	IORE5100-20-MT	3/7
FPL6929002R0006	IORE5100-30-MT	3/7
FPL6935001R0006	LORR5100-20	5/8
FPL6935110R0006	LORR5100-10	5/8
FPL6939001R0006	LORE5100-20	5/9
FPL6939110R0006	LORE5100-10	5/9
FPL7101403R0001	VM21/24	7/7
FPL7108201P0001	4NMW1039	7/8
FPL7110116R0006	IORE63-10-CC	4/5
FPL7110216R0006	IORE63-20-CC	4/5
FPL7112136R0006	IOR63-10-CC-AMA	4/9
FPL7112236R0006	IOR63-20-CC-AMA	4/9
FPL7116116R0006	IORR63-10-CC	4/4
FPL7116136R0006	IORR63-10-CC-AMA	4/8
FPL7116216R0006	IORR63-20-CC	4/4
FPL7116236R0006	IORR63-20-CC-AMA	4/8
FPL7121236R0006	IOR63-20-MT-AMA	3/11
FPL7121336R0006	IOR63-30-MT-AMA	3/11
FPL7121436R0006	IOR63-40-MT-AMA	3/11
FPL7125216R0006	IORR63-20-MT	3/6

Order code	Type	Page
FPL7125236R0006	IORR63-20-MT-AMA	3/10
FPL7125336R0006	IORR63-30-MT-AMA	3/10
FPL7125386R0006	IORR63-30-MT	3/6
FPL7125416R0006	IORR63-40-MT	3/6
FPL7125436R0006	IORR63-40-MT-AMA	3/10
FPL7129216R0006	IORE63-20-MT	3/7
FPL7129386R0006	IORE63-30-MT	3/7
FPL7129416R0006	IORE63-40-MT	3/7
FPL7140116R0006	NORE63-01-CC	5/4
FPL7140216R0006	NORE63-02-CC	5/4
FPL7140516R0006	NORE63-21-CC	5/4
FPL7140716R0006	NORE63-31-CC	5/4
FPL7146116R0006	NORR63-01-CC	5/4
FPL7146216R0006	NORR63-02-CC	5/4
FPL7146516R0006	NORR63-21-CC	5/4
FPL7146716R0006	NORR63-31-CC	5/4
FPL7155216R0006	NORR63-02-MT	5/3
FPL7155516R0006	NORR63-21-MT	5/3
FPL7155716R0006	NORR63-31-MT	5/3
FPL7159216R0006	NORE63-02-MT	5/3
FPL7159516R0006	NORE63-21-MT	5/3
FPL7159716R0006	NORE63-31-MT	5/3
FPL7235110R0006	LORR85-10	5/8
FPL7235210R0006	LORR85-20	5/8
FPL7235310R0006	LORR85-30	5/8
FPL7235410R0006	LORR85-40	5/8
FPL7239110R0006	LORE85-10	5/9
FPL7239210R0006	LORE85-20	5/9
FPL7239310R0006	LORE85-30	5/9
FPL7239410R0006	LORE85-40	5/9
FPL7401404R0001	VM25	7/7
FPL7410115R0006	IORE125-10-CC	4/5
FPL7410215R0006	IORE125-20-CC	4/5
FPL7412135R0006	IOR125-10-CC-AMA	4/9
FPL7412235R0006	IOR125-20-CC-AMA	4/9
FPL7416115R0006	IORR125-10-CC	4/4
FPL7416135R0006	IORR125-10-CC-AMA	4/8
FPL7416215R0006	IORR125-20-CC	4/4
FPL7416235R0006	IORR125-20-CC-AMA	4/8
FPL7421235R0006	IOR125-20-MT-AMA	3/11
FPL7421335R0006	IOR125-30-MT-AMA	3/11
FPL7421435R0006	IOR125-40-MT-AMA	3/11
FPL7425215R0006	IORR125-20-MT	3/6
FPL7425235R0006	IORR125-20-MT-AMA	3/10
FPL7425315R0006	IORR125-30-MT	3/6
FPL7425335R0006	IORR125-30-MT-AMA	3/10
FPL7425415R0006	IORR125-40-MT	3/6
FPL7425435R0006	IORR125-40-MT-AMA	3/10
FPL7429215R0006	IORE125-20-MT	3/7
FPL7429315R0006	IORE125-30-MT	3/7
FPL7429415R0006	IORE125-40-MT	3/7
FPL7440115R0006	NORE125-01-CC	5/4
FPL7440215R0006	NORE125-02-CC	5/4
FPL7440515R0006	NORE125-21-CC	5/4
FPL7440715R0006	NORE125-31-CC	5/4
FPL7446115R0006	NORR125-01-CC	5/4
FPL7446215R0006	NORR125-02-CC	5/4
FPL7446515R0006	NORR125-21-CC	5/4
FPL7446715R0006	NORR125-31-CC	5/4
FPL7455215R0006	NORR125-02-MT	5/3
FPL7455515R0006	NORR125-21-MT	5/3
FPL7455715R0006	NORR125-31-MT	5/3
FPL7459215R0006	NORE125-02-MT	5/3
FPL7459515R0006	NORE125-21-MT	5/3
FPL7459715R0006	NORE125-31-MT	5/3
FPL7535110R0006	LORR170-10	5/8
FPL7535210R0006	LORR170-20	5/8
FPL7535310R0006	LORR170-30	5/8
FPL7535410R0006	LORR170-40	5/8
FPL7539110R0006	LORE170-10	5/9
FPL7539210R0006	LORE170-20	5/9
FPL7539310R0006	LORE170-30	5/9
FPL7539410R0006	LORE170-40	5/9

Order code	Type	Page
FPL7608201P0001	4NMW1039	7/8
FPL7610115R0006	IORE200-10-CC	4/5
FPL7610215R0006	IORE200-20-CC	4/5
FPL7612135R0006	IOR200-10-CC-AMA	4/9
FPL7612235R0006	IOR200-20-CC-AMA	4/9
FPL7616115R0006	IORR200-10-CC	4/4
FPL7616135R0006	IORR200-10-CC-AMA	4/8
FPL7616215R0006	IORR200-20-CC	4/4
FPL7616235R0006	IORR200-20-CC-AMA	4/8
FPL7621235R0006	IOR200-20-MT-AMA	3/11
FPL7621335R0006	IOR200-30-MT-AMA	3/11
FPL7621435R0006	IOR200-40-MT-AMA	3/11
FPL7625215R0006	IORR200-20-MT	3/6
FPL7625235R0006	IORR200-20-MT-AMA	3/10
FPL7625315R0006	IORR200-30-MT	3/6
FPL7625335R0006	IORR200-30-MT-AMA	3/10
FPL7625415R0006	IORR200-40-MT	3/6
FPL7625435R0006	IORR200-40-MT-AMA	3/10
FPL7629215R0006	IORE200-20-MT	3/7
FPL7629315R0006	IORE200-30-MT	3/7
FPL7629415R0006	IORE200-40-MT	3/7
FPL7640115R0006	NORE200-01-CC	5/4
FPL7640215R0006	NORE200-02-CC	5/4
FPL7640515R0006	NORE200-21-CC	5/4
FPL7640715R0006	NORE200-31-CC	5/4
FPL7646115R0006	NORR200-01-CC	5/4
FPL7646215R0006	NORR200-02-CC	5/4
FPL7646515R0006	NORR200-21-CC	5/4
FPL7646715R0006	NORR200-31-CC	5/4
FPL7655215R0006	NORR200-02-MT	5/3
FPL7655515R0006	NORR200-21-MT	5/3
FPL7655715R0006	NORR200-31-MT	5/3
FPL7659215R0006	NORE200-02-MT	5/3
FPL7659515R0006	NORE200-21-MT	5/3
FPL7659715R0006	NORE200-31-MT	5/3
FPL7835110R0006	LORR260-10	5/8
FPL7835210R0006	LORR260-20	5/8
FPL7835310R0006	LORR260-30	5/8
FPL7835410R0006	LORR260-40	5/8
FPL7839110R0006	LORE260-10	5/9
FPL7839210R0006	LORE260-20	5/9
FPL7839310R0006	LORE260-30	5/9
FPL7839410R0006	LORE260-40	5/9
FPL8301401R0002	VM15-SP	7/7
FPL8308201P0001	4NMW1041	7/8
FPL8310115R0006	IORE500-10-CC	4/5
FPL8310125R0116	IORE500-10-CC-AME	4/9
FPL8310215R0006	IORE500-20-CC	4/5
FPL8310225R0116	IORE500-20-CC-AME	4/9
FPL8316115R0006	IORR500-10-CC	4/4
FPL8316215R0006	IORR500-10-CC-AME	4/8
FPL831625R0116	IORR500-20-CC	4/4
FPL8316225R0116	IORR500-20-CC-AME	4/8
FPL8325215R0006	IORR500-20-MT	3/6
FPL8325225R0116	IORR500-20-MT-AME	3/10
FPL8325315R0006	IORR500-30-MT	3/6
FPL8325325R0116	IORR500-30-MT-AME	3/10
FPL8325415R0006	IORR500-40-MT	3/6
FPL8329215R0006	IORE500-20-MT	3/7
FPL8329225R0116	IORE500-20-MT-AME	3/11
FPL8329315R0006	IORE500-30-MT	3/7
FPL8329325R0116	IORE500-30-MT-AME	3/11
FPL8329415R0006	IORE500-40-MT	3/7
FPL8435110R0006	LORR550-10	5/8
FPL8435210R0006	LORR550-20	5/8
FPL8435310R0006	LORR550-30	5/8
FPL8435410R0006	LORR550-40	5/8
FPL8439110R0006	LORE550-10	5/9
FPL8439210R0006	LORE550-20	5/9
FPL8439310R0006	LORE550-30	5/9
FPL8439410R0006	LORE550-40	5/9
FPL8601401R0001	VM16	7/7
FPL8610115R0006	IORE800-10-CC	4/5

Index

Order code classification

Order code	Type	Page	Order code	Type	Page	Order code	Type	Page
FPL8610125R0116	IORE800-10-CC-AME	4/9	FPL8715325R0116	IORR1000-30-AME	3/8	FPTN410111R0003	-	7/8
FPL8610195R0006	IORE800-10-CC-U	4/7	FPL8715415R0006	IORR1000-40	3/4	FPTN410176R0006	NO poles	7/5
FPL8610215R0006	IORE800-20-CC	4/5	FPL8715425R0116	IORR1000-40-AME	3/8	FPTN410176R0007	NC poles	7/5
FPL8610225R0116	IORE800-20-CC-AME	4/9	FPL8716115R0006	IORR1000-10-CC	4/4	FPTN410200R0006	-	7/6
FPL8610315R0006	IORE800-30-CC	4/5	FPL8716125R0116	IORR1000-10-CC-AME	4/8	FPTN410213R0006	Mounting kit	7/2
FPL8610325R0116	IORE800-30-CC-AME	4/9	FPL8716195R0006	IORR1000-10-CC-U	4/6	FPTN410389R0001	-	7/4
FPL8615215R0006	IORR800-20	3/4	FPL8716215R0006	IORR1000-20-CC	4/4	FPTN410389R0002	-	7/4
FPL8615225R0116	IORR800-20-AME	3/8	FPL8716225R0116	IORR1000-20-CC-AME	4/8	FPTN410389R0003	-	7/4
FPL8615315R0006	IORR800-30	3/4	FPL8716315R0006	IORR1000-30-CC	4/4	FPTN410389R0004	-	7/4
FPL8615325R0116	IORR800-30-AME	3/8	FPL8716325R0116	IORR1000-30-CC-AME	4/8	FPTN410389R0005	-	7/4
FPL8615415R0006	IORR800-40	3/4	FPL8719215R0006	IORE1000-20	3/5	FPTN410390R0001	-	7/4
FPL8615425R0116	IORR800-40-AME	3/8	FPL8719225R0116	IORE1000-20-AME	3/9	FPTN410390R0002	-	7/4
FPL8616115R0006	IORR800-10-CC	4/4	FPL8719315R0006	IORE1000-30	3/5	FPTN410390R0003	-	7/4
FPL8616125R0116	IORR800-10-CC-AME	4/8	FPL8719325R0116	IORE1000-30-AME	3/9	FPTN410390R0004	-	7/4
FPL8616195R0006	IORR800-10-CC-U	4/6	FPL8719415R0006	IORE1000-40	3/5	FPTN410390R0005	-	7/4
FPL8616215R0006	IORR800-20-CC	4/4	FPL8719425R0116	IORE1000-40-AME	3/9	FPTN410391R0001	-	7/4
FPL8616225R0116	IORR800-20-CC-AME	4/8	FPL8801401R0001	VM17/18	7/7	FPTN410437R0001	-	7/6
FPL8616315R0006	IORR800-30-CC	4/4	FPL9001401R0001	VM19	7/7	FPTN410438R0001	-	7/6
FPL8616325R0116	IORR800-30-CC-AME	4/8	FPL9410115R0006	IORE400-10-CC	4/5	FPTN410439R0001	-	7/6
FPL8619215R0006	IORE800-20	3/5	FPL9410125R0116	IORE400-10-CC-AME	4/9	FPTN410441R0001	-	7/6
FPL8619225R0116	IORE800-20-AME	3/9	FPL9410215R0006	IORE400-20-CC	4/5	FPTN410446R0001	-	7/4
FPL8619315R0006	IORE800-30	3/5	FPL9410225R0116	IORE400-20-CC-AME	4/9	FPTN410463R6001	RV-R1/60	7/6
FPL8619325R0116	IORE800-30-AME	3/9	FPL9416115R0006	IORR400-10-CC	4/4	FPTN410463R6002	RV-R1/133	7/6
FPL8619415R0006	IORE800-40	3/5	FPL9416125R0116	IORR400-10-CC-AME	4/8	FPTN410463R6003	RV-R1/250	7/6
FPL8619425R0116	IORE800-40-AME	3/9	FPL9416215R0006	IORR400-20-CC	4/4	FPTN410463R6004	RV-R1/440	7/6
FPL8625215R0006	IORR800-20-MT	3/6	FPL9416225R0116	IORR400-20-CC-AME	4/8	FPTN410463R6005	RV-R1/660	7/6
FPL8625225R0116	IORR800-20-MT-AME	3/10	FPL9425215R0006	IORR400-20-MT	3/6	FPTN410503R0001	-	7/4
FPL8625315R0006	IORR800-30-MT	3/6	FPL9425225R0116	IORR400-20-MT-AME	3/10	FPTN410506R0001	-	7/4
FPL8625325R0116	IORR800-30-MT-AME	3/10	FPL9425315R0006	IORR400-30-MT	3/6	FPTN410507R0001	De-ion arc chute	7/5
FPL8625415R0006	IORR800-40-MT	3/6	FPL9425325R0116	IORR400-30-MT-AME	3/10	FPTN410508R0001	-	7/4
FPL8629215R0006	IORE800-20-MT	3/7	FPL9425415R0006	IORR400-40-MT	3/6			
FPL8629225R0116	IORE800-20-MT-AME	3/11	FPL9425925R0116	IORE400-20-MT-AME	3/11			
FPL8629315R0006	IORE800-30-MT	3/7	FPL9429215R0006	IORE400-20-MT	3/7			
FPL8629325R0116	IORE800-30-MT-AME	3/11	FPL9429315R0006	IORE400-30-MT	3/7			
FPL8629415R0006	IORE800-40-MT	3/7	FPL9429325R0116	IORE400-30-MT-AME	3/11			
FPL8635110R0006	LORR800-10	5/8	FPL9429415R0006	IORE400-40-MT	3/7			
FPL8635210R0006	LORR800-20	5/8	FPL9435110R0006	LORR400-10	5/8			
FPL8635310R0006	LORR800-30	5/8	FPL9435210R0006	LORR400-20	5/8			
FPL8635410R0006	LORR800-40	5/8	FPL9435310R0006	LORR400-30	5/8			
FPL8639110R0006	LORE800-10	5/9	FPL9435410R0006	LORR400-40	5/8			
FPL8639210R0006	LORE800-20	5/9	FPL9439110R0006	LORE400-10	5/9			
FPL8639310R0006	LORE800-30	5/9	FPL9439210R0006	LORE400-20	5/9			
FPL8639410R0006	LORE800-40	5/9	FPL9439310R0006	LORE400-30	5/9			
FPL8640115R0006	NORE800-01-CC	5/4	FPL9439410R0006	LORE400-40	5/9			
FPL8640215R0006	NORE800-02-CC	5/4	FPL9445115R0006	NORR400-01	5/4			
FPL8640515R0006	NORE800-21-CC	5/4	FPL9445215R0006	NORR400-02	5/3			
FPL8640715R0006	NORE800-31-CC	5/4	FPL9445515R0006	NORR400-21	5/3			
FPL8645215R0006	NORR800-02	5/3	FPL9445715R0006	NORR400-31	5/3			
FPL8645515R0006	NORR800-21	5/3	FPL9449115R0006	NORE400-01	5/4			
FPL8645715R0006	NORR800-31	5/3	FPL9449215R0006	NORE400-02	5/3			
FPL8646115R0006	NORR800-01-CC	5/4	FPL9449515R0006	NORE400-21	5/3			
FPL8646215R0006	NORR800-02-CC	5/4	FPL9449715R0006	NORE400-31	5/3			
FPL8646515R0006	NORR800-21-CC	5/4	FPTN210382R0003	CA15-F	7/2			
FPL8646715R0006	NORR800-31-CC	5/4	FPTN210382R0004	CA15-O	7/2			
FPL8649215R0006	NORE800-02	5/3	FPTN401936R0002	Basic arc chute	7/5			
FPL8649515R0006	NORE800-21	5/3	FPTN401938R0002	De-ion arc chute	7/5			
FPL8649715R0006	NORE800-31	5/3	FPTN401939R0002	De-ion arc chute	7/5			
FPL8655215R0006	NORR800-02-MT	5/3	FPTN401940R0002	De-ion arc chute	7/5			
FPL8655515R0006	NORR800-21-MT	5/3	FPTN401941R0002	De-ion arc chute	7/5			
FPL8655715R0006	NORR800-31-MT	5/3	FPTN410004R0001	CA12-1	7/2			
FPL8659215R0006	NORE800-02-MT	5/3	FPTN410005R0001	CA12-2	7/2			
FPL8659515R0006	NORE800-21-MT	5/3	FPTN410007R0006	CA15-O	7/2			
FPL8659715R0006	NORE800-31-MT	5/3	FPTN410008R0004	CA15-F	7/2			
FPL8710115R0006	IORE1000-10-CC	4/5	FPTN410012R0001	CA12-22	7/2			
FPL8710125R0116	IORE1000-10-CC-AME	4/9	FPTN410013R0001	CA12-11	7/2			
FPL8710195R0006	IORE1000-10-CC-U	4/7	FPTN410016R0001	CA12-12	7/2			
FPL8710215R0006	IORE1000-20-CC	4/5	FPTN410054R0016	Universal mounting kit	7/2			
FPL8710225R0116	IORE1000-20-CC-AME	4/9	FPTN410054R0017	Mounting kit	7/2			
FPL8710315R0006	IORE1000-30-CC	4/5	FPTN410056R0001	Support bracket	7/2			
FPL8710325R0116	IORE1000-30-CC-AME	4/9	FPTN410056R0002	Support bracket	7/2			
FPL8715215R0006	IORR1000-20	3/4	FPTN410067R0002	De-ion arc chute	7/5			
FPL8715225R0116	IORR1000-20-AME	3/8	FPTN410111R0001	-	7/8			
FPL8715315R0006	IORR1000-30	3/4	FPTN410111R0002	-	7/8			



Index

Type classification

Type	Order code	Page
4NMW1009	FPL7108201P0001	7/8
4NMW1039	FPL7608201P0001	7/8
4NMW1041	FPL8308201P0001	7/8
Basic arc chute	FPTN401936R0002	7/5
CA12-1	FPTN410004R0001	7/2
CA12-11	FPTN410013R0001	7/2
CA12-12	FPTN410016R0001	7/2
CA12-2	FPTN410005R0001	7/2
CA12-22	FPTN410012R0001	7/2
CA15-F	FPTN210382R0003	7/2
	FPTN410008R0004	7/2
CA15-O	FPTN210382R0004	7/2
	FPTN410007R0006	7/2
De-ion arc chute	FPTN401938R0002	7/5
	FPTN401939R0002	7/5
	FPTN401940R0002	7/5
	FPTN401941R0002	7/5
	FPTN410067R0002	7/5
	FPTN410507R0001	7/5
IOR125-10-CC-AMA	FPL7412135R0006	4/9
IOR125-20-CC-AMA	FPL7412235R0006	4/9
IOR125-20-MT-AMA	FPL7421235R0006	3/11
IOR125-30-MT-AMA	FPL7421335R0006	3/11
IOR125-40-MT-AMA	FPL7421435R0006	3/11
IOR200-10-CC-AMA	FPL7612135R0006	4/9
IOR200-20-CC-AMA	FPL7612235R0006	4/9
IOR200-20-MT-AMA	FPL7621235R0006	3/11
IOR200-30-MT-AMA	FPL7621335R0006	3/11
IOR200-40-MT-AMA	FPL7621435R0006	3/11
IOR63-10-CC-AMA	FPL7112136R0006	4/9
IOR63-20-CC-AMA	FPL7112236R0006	4/9
IOR63-20-MT-AMA	FPL7112136R0006	3/11
IOR63-30-MT-AMA	FPL7121336R0006	3/11
IOR63-40-MT-AMA	FPL7121436R0006	3/11
IOR1000-10-CC	FPL8710115R0006	4/5
IOR1000-10-CC-AME	FPL8710125R0116	4/9
IOR1000-10-CC-U	FPL8710195R0006	4/7
IOR1000-20	FPL8719215R0006	3/5
IOR1000-20-AME	FPL8719225R0116	3/9
IOR1000-20-CC	FPL8710215R0006	4/5
IOR1000-20-CC-AME	FPL8710225R0116	4/9
IOR1000-30	FPL8719315R0006	3/5
IOR1000-30-AME	FPL8719325R0116	3/9
IOR1000-30-CC	FPL8710315R0006	4/5
IOR1000-30-CC-AME	FPL8710325R0116	4/9
IOR1000-40	FPL8719415R0006	3/5
IOR1000-40-AME	FPL8719425R0116	3/9
IOR125-10-CC	FPL7410115R0006	4/5
IOR125-20-CC	FPL7410215R0006	4/5
IOR125-20-MT	FPL7429215R0006	3/7
IOR125-30-MT	FPL7429315R0006	3/7
IOR125-40-MT	FPL7429415R0006	3/7
IOR1400-10-CC	FPL6110115R0006	4/5
IOR1400-10-CC-AME	FPL6110125R0116	4/9
IOR1400-10-CC-U	FPL6110195R0006	4/7
IOR1400-20	FPL6119215R0006	3/5
IOR1400-20-AME	FPL6119225R0116	3/9
IOR1400-20-CC	FPL6110215R0006	4/5
IOR1400-20-CC-AME	FPL6110225R0116	4/9
IOR1400-20-MT	FPL6129215R0006	3/7
IOR1400-20-MT-AME	FPL6129225R0116	3/11
IOR1400-30	FPL6119315R0006	3/5
IOR1400-30-AME	FPL6119325R0116	3/9
IOR1400-30-CC	FPL6110315R0006	4/5
IOR1400-30-CC-AME	FPL6110325R0116	4/9
IOR1400-30-MT	FPL6129315R0006	3/7
IOR1400-30-MT-AME	FPL6129325R0116	3/11
IOR1400-40	FPL6119415R0006	3/5
IOR1400-40-AME	FPL6119425R0116	3/9
IOR1400-40-MT	FPL6129415R0006	3/7
IOR1700-10-CC	FPL6210185R0006	4/5
IOR1700-10-CC-AME	FPL6210125R0116	4/9
IOR1700-10-CC-U	FPL6210195R0006	4/7

Type	Order code	Page
IOR1700-20	FPL6219215R0006	3/5
IOR1700-20-AME	FPL6219225R0116	3/9
IOR1700-20-CC	FPL6210215R0006	4/5
IOR1700-20-CC-AME	FPL6210225R0116	4/9
IOR1700-20-MT	FPL6229215R0006	3/7
IOR1700-20-MT-AME	FPL6229225R0116	3/11
IOR1700-30	FPL6219315R0006	3/5
IOR1700-30-AME	FPL6219325R0116	3/9
IOR1700-30-CC	FPL6210315R0006	4/5
IOR1700-30-CC-AME	FPL6210325R0116	4/9
IOR1700-30-CC-AME	FPL6210325R0116	4/9
IOR1700-30-MT-AME	FPL6229315R0006	3/7
IOR1700-30-MT	FPL6229315R0006	3/7
IOR1700-40	FPL6219415R0006	3/5
IOR1700-40-AME	FPL6219425R0116	3/9
IOR1700-40-MT	FPL6229415R0006	3/7
IORE200-10-CC	FPL7610115R0006	4/5
IORE200-20-CC	FPL7610215R0006	4/5
IORE200-20-MT	FPL7629215R0006	3/7
IORE200-30-MT	FPL7629315R0006	3/7
IORE200-40-MT	FPL7629415R0006	3/7
IORE2100-10-CC	FPL6310185R0006	4/5
IORE2100-10-CC-AME	FPL6310125R0116	4/9
IORE2100-10-CC-U	FPL6310195R0006	4/7
IORE2100-20	FPL6319215R0006	3/5
IORE2100-20-AME	FPL6319225R0116	3/9
IORE2100-20-CC	FPL6310215R0006	4/5
IORE2100-20-CC-AME	FPL6310225R0116	4/9
IORE2100-20-MT	FPL6329215R0006	3/7
IORE2100-20-MT-AME	FPL6329225R0116	3/11
IORE2100-30	FPL6319315R0006	3/5
IORE2100-30-AME	FPL6319325R0116	3/9
IORE2100-30-CC	FPL6310315R0006	4/5
IORE2100-30-CC-AME	FPL6310325R0116	4/9
IORE2100-30-MT	FPL6329315R0006	3/7
IORE2100-30-MT-AME	FPL6329325R0116	3/11
IORE2100-40	FPL6319415R0006	3/5
IORE2100-40-AME	FPL6319425R0116	3/9
IORE2100-40-MT	FPL6329415R0006	3/7
IORE2500-10-CC	FPL6710115R0006	4/5
IORE2500-10-CC-AME	FPL6710125R0116	4/9
IORE2500-20	FPL6719215R0006	3/5
IORE2500-20-AME	FPL6719225R0116	3/9
IORE2500-20-CC	FPL6710215R0006	4/5
IORE2500-20-CC-AME	FPL6710225R0116	4/9
IORE2500-20-MT	FPL6729215R0006	3/7
IORE2500-20-MT-AME	FPL6729225R0116	3/11
IORE2500-30	FPL6719315R0006	3/5
IORE2500-30-AME	FPL6719325R0116	3/9
IORE2500-30-CC	FPL6710315R0006	4/5
IORE2500-30-CC-AME	FPL6710325R0116	4/9
IORE2500-30-MT	FPL6729315R0006	3/7
IORE2500-30-MT-AME	FPL6729325R0116	3/11
IORE2500-40-MT	FPL6729415R0006	3/7
IORE3200-10-CC	FPL6510115R0006	4/5
IORE3200-10-CC-AME	FPL6510125R0116	4/9
IORE3200-20	FPL6519215R0006	3/5
IORE3200-20-AME	FPL6519225R0116	3/9
IORE3200-20-CC	FPL6510215R0006	4/5
IORE3200-20-CC-AME	FPL6510225R0116	4/9
IORE3200-20-MT	FPL6529215R0006	3/7
IORE3200-20-MT-AME	FPL6529225R0116	3/11
IORE3200-30	FPL6519315R0006	3/5
IORE3200-30-AME	FPL6519325R0116	3/9
IORE3200-30-CC	FPL6510315R0006	4/5
IORE3200-30-CC-AME	FPL6510325R0116	4/9
IORE3200-30-MT	FPL6529315R0006	3/7
IORE3200-30-MT-AME	FPL6529325R0116	3/11
IORE3800-10-CC	FPL6610115R0006	4/5
IORE3800-10-CC-AME	FPL6610125R0116	4/9
IORE3800-20	FPL6619215R0006	3/5
IORE3800-20-AME	FPL6619225R0116	3/9
IORE3800-20-CC	FPL6610215R0006	4/5
IORE3800-20-CC-AME	FPL6610225R0116	4/9
IORE3800-20-MT	FPL6629215R0006	3/7
IORE3800-20-MT-AME	FPL6629225R0116	3/11
IORE400-10-CC	FPL9410115R0006	4/5
IORE400-10-CC-AME	FPL9410125R0116	4/9
IORE400-20-CC	FPL9410215R0006	4/5
IORE400-20-CC-AME	FPL9410225R0116	4/9
IORE400-20-MT	FPL9429215R0006	3/7
IORE400-20-MT-AME	FPL9429225R0116	3/11
IORE400-30-MT	FPL9429315R0006	3/7
IORE400-30-MT-AME	FPL9429325R0116	3/11
IORE400-40-MT	FPL9429415R0006	3/7
IORE4500-10-CC	FPL6810115R0006	4/5
IORE4500-10-CC-AME	FPL6810125R0116	4/9
IORE4500-20	FPL6819215R0006	3/5
IORE4500-20-AME	FPL6819225R0116	3/9
IORE4500-20-CC	FPL6810215R0006	4/5
IORE4500-20-CC-AME	FPL6810225R0116	4/9
IORE4500-20-MT	FPL6829215R0006	3/7
IORE4500-20-MT-AME	FPL6829225R0116	3/11
IORE4500-30	FPL6819001R0006	3/5
IORE4500-30-MT	FPL6829001R0006	3/7
IORE500-10-CC	FPL8310115R0006	4/5
IORE500-10-CC-AME	FPL8310125R0116	4/9
IORE500-20-CC	FPL8310215R0006	4/5
IORE500-20-CC-AME	FPL8310225R0116	4/9
IORE500-20-MT	FPL8329215R0006	3/7
IORE500-20-MT-AME	FPL8329225R0116	3/11
IORE500-30-MT	FPL8329315R0006	3/7
IORE500-30-MT-AME	FPL8329325R0116	3/11
IORE500-40-MT	FPL8329415R0006	3/7
IORE5100-10-CC	FPL6910115R0006	4/5
IORE5100-10-CC-AME	FPL6910125R0116	4/9
IORE5100-20	FPL6919001R0006	3/5
IORE5100-20-MT	FPL6929001R0006	3/7
IORE5100-30	FPL6919002R0006	3/5
IORE5100-30-MT	FPL6929002R0006	3/7
IORE63-10-CC	FPL7110116R0006	4/5
IORE63-20-CC	FPL7110216R0006	4/5
IORE63-20-MT	FPL7129216R0006	3/7
IORE63-30-MT	FPL7129386R0006	3/7
IORE63-40-MT	FPL7129416R0006	3/7
IORE800-10-CC	FPL8610115R0006	4/5
IORE800-10-CC-AME	FPL8610125R0116	4/9
IORE800-10-CC-U	FPL8610195R0006	4/7
IORE800-20	FPL8619215R0006	3/5
IORE800-20-AME	FPL8619225R0116	3/9
IORE800-20-CC	FPL8610215R0006	4/5
IORE800-20-CC-AME	FPL8610225R0116	4/9
IORE800-20-MT	FPL8629215R0006	3/7
IORE800-20-MT-AME	FPL8629225R0116	3/11
IORE800-30	FPL8619315R0006	3/5
IORE800-30-AME	FPL8619325R0116	3/9
IORE800-30-CC	FPL8610315R0006	4/5
IORE800-30-CC-AME	FPL8610325R0116	4/9
IORE800-30-MT	FPL8629315R0006	3/7
IORE800-30-MT-AME	FPL8629325R0116	3/11
IORE800-40	FPL8619415R0006	3/5
IORE800-40-AME	FPL8619425R0116	3/9
IORE800-40-MT	FPL8629415R0006	3/7
IORR1000-10-CC	FPL8716115R0006	4/4
IORR1000-10-CC-AME	FPL8716125R0116	4/8
IORR1000-10-CC-U	FPL8716195R0006	4/6
IORR1000-20	FPL8715215R0006	3/4
IORR1000-20-AME	FPL8715225R0116	3/8
IORR1000-20-CC	FPL8716215R0006	4/4
IORR1000-20-CC-AME	FPL8716225R0116	4/8
IORR1000-30	FPL8715315R0006	3/4
IORR1000-30-AME	FPL8715325R0116	3/8
IORR1000-30-CC	FPL8716315R0006	4/4
IORR1000-30-CC-AME	FPL8716325R0116	4/8

Index

Type classification

Type	Order code	Page	Type	Order code	Page	Type	Order code	Page
IORR1000-40	FPL8715415R0006	3/4	IORR2100-40	FPL6315415R0006	3/4	IORR5100-20	FPL6915001R0006	3/4
IORR1000-40-AME	FPL8715425R0116	3/8	IORR2100-40-AME	FPL6315425R0116	3/8	IORR5100-20-MT	FPL6925001R0006	3/6
IORR125-10-CC	FPL7416115R0006	4/4	IORR2100-40-MT	FPL6325415R0006	3/6	IORR5100-30	FPL6915002R0006	3/4
IORR125-10-CC-AMA	FPL7416135R0006	4/8	IORR2500-10-CC	FPL6716115R0006	4/4	IORR5100-30-MT	FPL6925002R0006	3/6
IORR125-20-CC	FPL7416215R0006	4/4	IORR2500-10-CC-AME	FPL6716125R0116	4/8	IORR63-10-CC	FPL7116116R0006	4/4
IORR125-20-CC-AMA	FPL7416235R0006	4/8	IORR2500-20	FPL6715215R0006	3/4	IORR63-10-CC-AMA	FPL7116136R0006	4/8
IORR125-20-MT	FPL7425215R0006	3/6	IORR2500-20-AME	FPL6715225R0116	3/8	IORR63-20-CC	FPL7116216R0006	4/4
IORR125-20-MT-AMA	FPL7425235R0006	3/10	IORR2500-20-CC	FPL6716215R0006	4/4	IORR63-20-CC-AMA	FPL7116236R0006	4/8
IORR125-30-MT	FPL7425315R0006	3/6	IORR2500-20-CC-AME	FPL6716225R0116	4/8	IORR63-20-MT	FPL7125216R0006	3/6
IORR125-30-MT-AMA	FPL7425335R0006	3/10	IORR2500-20-MT	FPL6725215R0006	3/6	IORR63-20-MT-AMA	FPL7125236R0006	3/10
IORR125-40-MT	FPL7425415R0006	3/6	IORR2500-20-MT-AME	FPL6725225R0116	3/10	IORR63-30-MT	FPL7125386R0006	3/6
IORR125-40-MT-AMA	FPL7425435R0006	3/10	IORR2500-30	FPL6715315R0006	3/4	IORR63-30-MT-AMA	FPL7125336R0006	3/10
IORR1400-10-CC	FPL6116115R0006	4/4	IORR2500-30-AME	FPL6715325R0116	3/8	IORR63-40-MT	FPL7125416R0006	3/6
IORR1400-10-CC-AME	FPL6116125R0116	4/8	IORR2500-30-CC	FPL6716315R0006	4/4	IORR63-40-MT-AMA	FPL7125436R0006	3/10
IORR1400-10-CC-U	FPL6116195R0006	4/6	IORR2500-30-CC-AME	FPL6716325R0116	4/8	IORR800-10-CC	FPL8616115R0006	4/4
IORR1400-20	FPL6115215R0006	3/4	IORR2500-30-MT	FPL6725315R0006	3/6	IORR800-10-CC-AME	FPL8616125R0116	4/8
IORR1400-20-AME	FPL6115225R0116	3/8	IORR2500-30-MT-AME	FPL6725325R0116	3/10	IORR800-10-CC-U	FPL8616195R0006	4/6
IORR1400-20-CC	FPL6116215R0006	4/4	IORR2500-40-MT	FPL6725415R0006	3/6	IORR800-20	FPL8615215R0006	3/4
IORR1400-20-CC-AME	FPL6116225R0116	4/8	IORR3200-10-CC	FPL6516115R0006	4/4	IORR800-20-AME	FPL8615225R0116	3/8
IORR1400-20-MT	FPL6125215R0006	3/6	IORR3200-10-CC-AME	FPL6516125R0116	4/8	IORR800-20-CC	FPL8616215R0006	4/4
IORR1400-20-MT-AME	FPL6125225R0116	3/10	IORR3200-20	FPL6515215R0006	3/4	IORR800-20-CC-AME	FPL8616225R0116	4/8
IORR1400-30	FPL6115315R0006	3/4	IORR3200-20-AME	FPL6515225R0116	3/8	IORR800-20-MT	FPL8625215R0006	3/6
IORR1400-30-AME	FPL6115325R0116	3/8	IORR3200-20-CC	FPL6516215R0006	4/4	IORR800-20-MT-AME	FPL8625225R0116	3/10
IORR1400-30-CC	FPL6116315R0006	4/4	IORR3200-20-CC-AME	FPL6516225R0116	4/8	IORR800-30	FPL8615315R0006	3/4
IORR1400-30-CC-AME	FPL6116325R0116	4/8	IORR3200-20-MT	FPL6525215R0006	3/6	IORR800-30-AME	FPL8615325R0116	3/8
IORR1400-30-CC-U	FPL6116335R0006	3/6	IORR3200-20-MT-AME	FPL6525225R0116	3/10	IORR800-30-CC	FPL8616315R0006	4/4
IORR1400-30-MT	FPL6125315R0006	3/6	IORR3200-30	FPL6515315R0006	3/4	IORR800-30-CC-AME	FPL8616325R0116	4/8
IORR1400-30-MT-AME	FPL6125325R0116	3/10	IORR3200-30-AME	FPL6515325R0116	3/8	IORR800-30-MT	FPL8625315R0006	3/6
IORR1400-40	FPL6115415R0006	3/4	IORR3200-30-CC	FPL6516315R0006	4/4	IORR800-30-MT-AME	FPL8625325R0116	3/10
IORR1400-40-AME	FPL6115425R0116	3/8	IORR3200-30-CC-AME	FPL6516325R0116	4/8	IORR800-40	FPL8615415R0006	3/4
IORR1400-40-MT	FPL6125415R0006	3/6	IORR3200-30-MT	FPL6525315R0006	3/6	IORR800-40-AME	FPL8615425R0116	3/8
IORR1400-40-MT-AME	FPL6125425R0116	3/10	IORR3200-30-MT-AME	FPL6525325R0116	3/10	IORR800-40-MT	FPL8625415R0006	3/6
IORR1700-10-CC	FPL6216185R0006	4/4	IORR3800-10-CC	FPL6616115R0006	4/4	LORE1400-10	FPL6139110R0006	5/9
IORR1700-10-CC-AME	FPL6216125R0116	4/8	IORR3800-10-CC-AME	FPL6616125R0116	4/8	LORE1400-20	FPL6139210R0006	5/9
IORR1700-10-CC-U	FPL6216195R0006	4/6	IORR3800-20	FPL6615215R0006	3/4	LORE1400-30	FPL6139310R0006	5/9
IORR1700-20	FPL6215215R0006	3/4	IORR3800-20-AME	FPL6615225R0116	3/8	LORE1400-40	FPL6139410R0006	5/9
IORR1700-20-AME	FPL6215225R0116	3/8	IORR3800-20-CC	FPL6616215R0006	4/4	LORE1700-10	FPL6239110R0006	5/9
IORR1700-20-CC	FPL6216215R0006	4/4	IORR3800-20-CC-AME	FPL6616225R0116	4/8	LORE1700-20	FPL6239210R0006	5/9
IORR1700-20-CC-AME	FPL6216225R0116	4/8	IORR3800-20-MT	FPL6625215R0006	3/6	LORE1700-30	FPL6239310R0006	5/9
IORR1700-20-MT	FPL6225215R0006	3/6	IORR3800-20-MT-AME	FPL6625225R0116	3/10	LORE1700-40	FPL6239410R0006	5/9
IORR1700-20-MT-AME	FPL6225225R0116	3/10	IORR3800-30	FPL6615001R0006	3/4	LORE170-10	FPL7539110R0006	5/9
IORR1700-30	FPL6215315R0006	3/4	IORR3800-30-MT	FPL6625001R0006	3/6	LORE170-20	FPL7539210R0006	5/9
IORR1700-30-AME	FPL6215325R0116	3/8	IORR3800-30-MT-AME	FPL6625325R0116	3/10	LORE170-30	FPL7539310R0006	5/9
IORR1700-30-CC	FPL6216315R0006	4/4	IORR400-10-CC	FPL9416115R0006	4/4	LORE170-40	FPL7539410R0006	5/9
IORR1700-30-CC-AME	FPL6216325R0116	4/8	IORR400-10-CC-AME	FPL9416125R0116	4/8	LORE2100-10	FPL6339110R0006	5/9
IORR1700-30-MT	FPL6225315R0006	3/6	IORR400-20-CC	FPL9416215R0006	4/4	LORE2100-20	FPL6339210R0006	5/9
IORR1700-30-MT-AME	FPL6225325R0116	3/10	IORR400-20-CC-AME	FPL9416225R0116	4/8	LORE2100-30	FPL6339310R0006	5/9
IORR1700-40	FPL6215415R0006	3/4	IORR400-20-MT	FPL9425215R0006	3/6	LORE2100-40	FPL6339410R0006	5/9
IORR1700-40-AME	FPL6215425R0116	3/8	IORR400-20-MT-AME	FPL9425225R0116	3/10	LORE2500-10	FPL6739110R0006	5/9
IORR1700-40-MT	FPL6225415R0006	3/6	IORR400-30-MT	FPL9425315R0006	3/6	LORE2500-20	FPL6739210R0006	5/9
IORR200-10-CC	FPL7616115R0006	4/4	IORR400-30-MT-AME	FPL9425325R0116	3/10	LORE2500-30	FPL6739310R0006	5/9
IORR200-10-CC-AMA	FPL7616135R0006	4/8	IORR400-40-MT	FPL9425415R0006	3/6	LORE2500-40	FPL6739410R0006	5/9
IORR200-20-CC	FPL7616215R0006	4/4	IORR4500-10-CC	FPL6816115R0006	4/4	LORE260-10	FPL7839110R0006	5/9
IORR200-20-CC-AMA	FPL7616235R0006	4/8	IORR4500-10-CC-AME	FPL6816125R0116	4/8	LORE260-20	FPL7839210R0006	5/9
IORR200-20-MT	FPL7625215R0006	3/6	IORR4500-20	FPL6815215R0006	3/4	LORE260-30	FPL7839310R0006	5/9
IORR200-20-MT-AMA	FPL7625235R0006	3/10	IORR4500-20-AME	FPL6815225R0116	3/8	LORE260-40	FPL7839410R0006	5/9
IORR200-30-MT	FPL7625315R0006	3/6	IORR4500-20-CC	FPL6816215R0006	4/4	LORE3200-10	FPL6539110R0006	5/9
IORR200-30-MT-AMA	FPL7625335R0006	3/10	IORR4500-20-CC-AME	FPL6816225R0116	4/8	LORE3200-20	FPL6539210R0006	5/9
IORR200-40-MT	FPL7625415R0006	3/6	IORR4500-20-MT	FPL6825215R0006	3/6	LORE3200-30	FPL6591310R0006	5/9
IORR200-40-MT-AMA	FPL7625435R0006	3/10	IORR4500-20-MT-AME	FPL6825225R0116	3/10	LORE3200-40	FPL6539001R0006	5/9
IORR2100-10-CC	FPL6316185R0006	4/4	IORR4500-30	FPL6815001R0006	3/4	LORE3800-10	FPL6639110R0006	5/9
IORR2100-10-CC-AME	FPL6316125R0116	4/8	IORR4500-30-MT	FPL6825002R0006	3/6	LORE3800-20	FPL6639210R0006	5/9
IORR2100-10-CC-U	FPL6316195R0006	4/6	IORR500-10-CC	FPL8316115R0006	4/4	LORE3800-30	FPL6639002R0006	5/9
IORR2100-20	FPL6315215R0006	3/4	IORR500-10-CC-AME	FPL8316125R0116	4/8	LORE3800-40	FPL6639003R0006	5/9
IORR2100-20-AME	FPL6315225R0116	3/8	IORR500-20-CC	FPL8316215R0006	4/4	LORE400-10	FPL9439110R0006	5/9
IORR2100-20-CC	FPL6316215R0006	4/4	IORR500-20-CC-AME	FPL8316225R0116	4/8	LORE400-20	FPL9439210R0006	5/9
IORR2100-20-CC-AME	FPL6316225R0116	4/8	IORR500-20-MT	FPL8325215R0006	3/6	LORE400-30	FPL9439310R0006	5/9
IORR2100-20-MT	FPL6325215R0006	3/6	IORR500-20-MT-AME	FPL8325225R0116	3/10	LORE400-40	FPL9439410R0006	5/9
IORR2100-20-MT-AME	FPL6325225R0116	3/10	IORR500-30-MT	FPL8325315R0006	3/6	LORE4500-10	FPL6839110R0006	5/9
IORR2100-30	FPL6315315R0006	3/4	IORR500-30-CC	FPL8325325R0116	3/10	LORE4500-20	FPL6839210R0006	5/9
IORR2100-30-AME	FPL6315325R0116	3/8	IORR500-40-MT	FPL8325415R0006	3/6	LORE4500-30	FPL6839001R0006	5/9
IORR2100-30-CC	FPL6316315R0006	4/4	IORR5100-10-CC	FPL6916115R0006	4/4	LORE5100-10	FPL6939110R0006	5/9
IORR2100-30-CC-AME	FPL6316325R0116	4/8	IORR5100-10-CC-AME	FPL6916125R0116	4/8	LORE5100-20	FPL6939001R0006	5/9
IORR2100-30-MT	FPL6325315R0006	3/6						
IORR2100-30-MT-AME	FPL6325325R0116	3/10						



12

CHS Controls AB

Tel +46 42 38 61 00, Fax +46 42 38 61 29

chs@chscontrols.se www.chscontrols.se

Index

Type classification

Type	Order code	Page
LORE550-10	FPL8439110R0006	5/9
LORE550-20	FPL8439210R0006	5/9
LORE550-30	FPL8439310R0006	5/9
LORE550-40	FPL8439410R0006	5/9
LORE800-10	FPL8639110R0006	5/9
LORE800-20	FPL8639210R0006	5/9
LORE800-30	FPL8639310R0006	5/9
LORE800-40	FPL8639410R0006	5/9
LORE85-10	FPL7239110R0006	5/9
LORE85-20	FPL7239210R0006	5/9
LORE85-30	FPL7239310R0006	5/9
LORE85-40	FPL7239410R0006	5/9
LORR1400-10	FPL6135110R0006	5/8
LORR1400-20	FPL6135210R0006	5/8
LORR1400-30	FPL6135310R0006	5/8
LORR1400-40	FPL6135410R0006	5/8
LORR1700-10	FPL6235110R0006	5/8
LORR1700-20	FPL6235210R0006	5/8
LORR1700-30	FPL6235310R0006	5/8
LORR1700-40	FPL6235410R0006	5/8
LORR170-10	FPL7535110R0006	5/8
LORR170-20	FPL7535210R0006	5/8
LORR170-30	FPL7535310R0006	5/8
LORR170-40	FPL7535410R0006	5/8
LORR2100-10	FPL6335110R0006	5/8
LORR2100-20	FPL6335210R0006	5/8
LORR2100-30	FPL6335310R0006	5/8
LORR2100-40	FPL6335410R0006	5/8
LORR2500-10	FPL6735110R0006	5/8
LORR2500-20	FPL6735210R0006	5/8
LORR2500-30	FPL6735310R0006	5/8
LORR2500-40	FPL6735410R0006	5/8
LORR260-10	FPL7835110R0006	5/8
LORR260-20	FPL7835210R0006	5/8
LORR260-30	FPL7835310R0006	5/8
LORR260-40	FPL7835410R0006	5/8
LORR3200-10	FPL6535110R0006	5/8
LORR3200-20	FPL6535210R0006	5/8
LORR3200-30	FPL6535310R0006	5/8
LORR3200-40	FPL6535001R0006	5/8
LORR3800-10	FPL6635110R0006	5/8
LORR3800-20	FPL6635210R0006	5/8
LORR3800-30	FPL6635002R0006	5/8
LORR3800-40	FPL6635003R0006	5/8
LORR400-10	FPL9435110R0006	5/8
LORR400-20	FPL9435210R0006	5/8
LORR400-30	FPL9435310R0006	5/8
LORR400-40	FPL9435410R0006	5/8
LORR4500-10	FPL6835110R0006	5/8
LORR4500-20	FPL6835210R0006	5/8
LORR4500-30	FPL6835001R0006	5/8
LORR5100-10	FPL6935110R0006	5/8
LORR5100-20	FPL6935001R0006	5/8
LORR550-10	FPL8435110R0006	5/8
LORR550-20	FPL8435210R0006	5/8
LORR550-30	FPL8435310R0006	5/8
LORR550-40	FPL8435410R0006	5/8
LORR800-10	FPL8635110R0006	5/8
LORR800-20	FPL8635210R0006	5/8
LORR800-30	FPL8635310R0006	5/8
LORR800-40	FPL8635410R0006	5/8
LORR85-10	FPL7235110R0006	5/8
LORR85-20	FPL7235210R0006	5/8
LORR85-30	FPL7235310R0006	5/8
LORR85-40	FPL7235410R0006	5/8
Mounting kit	FPTN410054R0017	7/2
	FPTN410213R0006	7/2
NC poles	FPTN410176R0007	7/5
NO poles	FPTN410176R0006	7/5
NORE125-01-CC	FPL7440115R0006	5/4
NORE125-02-CC	FPL7440215R0006	5/4
NORE125-02-MT	FPL7459215R0006	5/3
NORE125-21-CC	FPL7440515R0006	5/4

Type	Order code	Page
NORE125-21-MT	FPL7459515R0006	5/3
NORE125-31-CC	FPL7440715R0006	5/4
NORE125-31-MT	FPL7459715R0006	5/3
NORE200-01-CC	FPL7640115R0006	5/4
NORE200-02-CC	FPL7640215R0006	5/4
NORE200-02-MT	FPL7659215R0006	5/3
NORE200-21-CC	FPL7640515R0006	5/4
NORE200-21-MT	FPL7659515R0006	5/3
NORE200-31-CC	FPL7640715R0006	5/4
NORE200-31-MT	FPL7659715R0006	5/3
NORE400-01	FPL9449115R0006	5/4
NORE400-02	FPL9449215R0006	5/3
NORE400-21	FPL9449515R0006	5/3
NORE400-31	FPL9449715R0006	5/3
NORE63-01-CC	FPL7140116R0006	5/4
NORE63-02-CC	FPL7140216R0006	5/4
NORE63-02-MT	FPL7159216R0006	5/3
NORE63-21-CC	FPL7140516R0006	5/4
NORE63-21-MT	FPL7159516R0006	5/3
NORE63-31-CC	FPL7140716R0006	5/4
NORE63-31-MT	FPL7159716R0006	5/3
NORE800-01-CC	FPL8640115R0006	5/4
NORE800-02	FPL8649215R0006	5/3
NORE800-02-CC	FPL8640215R0006	5/4
NORE800-02-MT	FPL8659215R0006	5/3
NORE800-21	FPL8649515R0006	5/3
NORE800-21-CC	FPL8640515R0006	5/4
NORE800-21-MT	FPL8659515R0006	5/3
NORE800-31	FPL8649715R0006	5/3
NORE800-31-CC	FPL8640715R0006	5/4
NORE800-31-MT	FPL8659715R0006	5/3
NORR125-01-CC	FPL7446115R0006	5/4
NORR125-02-CC	FPL7446215R0006	5/4
NORR125-02-MT	FPL7455215R0006	5/3
NORR125-21-CC	FPL7446515R0006	5/4
NORR125-21-MT	FPL7455515R0006	5/3
NORR125-31-CC	FPL7446715R0006	5/4
NORR125-31-MT	FPL7455715R0006	5/3
NORR200-01-CC	FPL7646115R0006	5/4
NORR200-02-CC	FPL7646215R0006	5/4
NORR200-02-MT	FPL7655215R0006	5/3
NORR200-21-CC	FPL7646515R0006	5/4
NORR200-21-MT	FPL7655515R0006	5/3
NORR200-31-CC	FPL7646715R0006	5/4
NORR200-31-MT	FPL7655715R0006	5/3
NORR400-01	FPL9445115R0006	5/4
NORR400-02	FPL9445215R0006	5/3
NORR400-21	FPL9445515R0006	5/3
NORR400-31	FPL9445715R0006	5/3
NORR63-01-CC	FPL7146116R0006	5/4
NORR63-02-CC	FPL7146216R0006	5/4
NORR63-02-MT	FPL7155216R0006	5/3
NORR63-21-CC	FPL7146516R0006	5/4
NORR63-21-MT	FPL7155516R0006	5/3
NORR63-31-CC	FPL7146716R0006	5/4
NORR63-31-MT	FPL7155716R0006	5/3
NORR800-01-CC	FPL8646115R0006	5/4
NORR800-02	FPL8645215R0006	5/3
NORR800-02-CC	FPL8646215R0006	5/4
NORR800-02-MT	FPL8655215R0006	5/3
NORR800-21	FPL8645515R0006	5/3
NORR800-21-CC	FPL8646515R0006	5/4
NORR800-21-MT	FPL8655515R0006	5/3
NORR800-31	FPL8645715R0006	5/3
NORR800-31-CC	FPL8646715R0006	5/4
NORR800-31-MT	FPL8655715R0006	5/3
RV-R1/133	FPTN410463R6002	7/6
RV-R1/250	FPTN410463R6003	7/6
RV-R1/440	FPTN410463R6004	7/6
RV-R1/60	FPTN410463R6001	7/6
RV-R1/660	FPTN410463R6005	7/6
Support bracket	FPTN410056R0001	7/2
	FPTN410056R0002	7/2

Type	Order code	Page
Universal mounting kit	FPTN410054R0016	7/2
VM15-SP	FPL8301401R0002	7/7
VM16	FPL8601401R0001	7/7
VM17/18	FPL8801401R0001	7/7
VM19	FPL9001401R0001	7/7
VM21/24	FPL7101403R0001	7/7
VM25	FPL7401404R0001	7/7





Service... you can trust



With a wide network of engineering expertise, eager to answer to our customers' every request, our service activity plays a proactive role in generating value for our customers. We keep their assets reliable and extend life cycles, while protecting customers' investments.







TELARC

Via E. Fermi 50, 20090 Trezzano sul Naviglio (Milano) – Italy
Phone/Fax +39.02.4969.9540 – email: info@telarc.it
www.telarc.it

Contact us

Telarc srl
Via E.Fermi 50
20090 Trezzano sul Naviglio
Milano
Italy